

DEPARTMENT OF THE ARMY TECHNICAL MANUAL

DEPARTMENT OF THE AIR FORCE TECHNICAL ORDER

TM 11-856

TO 31R1-2URR-154

# RADIO RECEIVER R-390/URR



DEPARTMENTS OF THE ARMY AND THE AIR FORCE

JANUARY 1955

TM 11-856/TO 31R1-2URR-154-RADIO RECEIVER R-390/URR-1955

4209  
401

**WARNING**

**DANGEROUS VOLTAGES EXIST IN THIS EQUIPMENT**

be careful when working on the plate,  
power supply, or ac input circuits.

**DON'T TAKE CHANCES**

DEPARTMENT OF THE ARMY TECHNICAL MANUAL AND DEPARTMENT OF  
THE AIR FORCE TECHNICAL ORDER

RADIO RECEIVER R-390/URR

TM 11-856  
TO 31R1-2URR-154  
CHANGES No. 1

DEPARTMENTS OF THE ARMY  
AND THE AIR FORCE  
WASHINGTON 25, D. C., 23 June 1955

TM 11-856/TO 31R1-2URR-154, 11 January 1955, is changed as follows:

On figure 8, at the small hole on the left-hand side of the frame, add the following call-out:

FOR C525 ADJUSTMENT TOOL.

### 13.1 Differences in Models

(Added)

During production many changes were made to the receivers. When these modifications were made to the equipments, the subchassis affected were stamped with a modification (MOD) number. This manual covers the latest equipment and lists the changes inserted in this manual which permit coverage of the earlier equipment.

*a. Changes in Equipment According to Serial Numbers.*

- (1) Below serial number 301, the access hole to capacitor C525 is not available on the left side of the main frame.
- (2) Below serial number 450, resistor R504 is connected to ground instead of to resistor R562.

*b. Changes in Equipment According to Rf Subchassis MOD Numbers.*

- (1) Below MOD 1, resistor R221 is 27 ohms.
- (2) Below MOD 2, capacitors C307 and C310 are each 1  $\mu\text{mf}$ ; C207 is 22  $\mu\text{mf}$ ; C248, C271, and C302 are each 24  $\mu\text{mf}$ ; C249, C272, and C303 are each 56  $\mu\text{mf}$ ; C274 is 510  $\mu\text{mf}$ ; C307 and C310 are each 1  $\mu\text{mf}$ ; and C289 is 68  $\mu\text{mf}$ . Resistor R203 is 100 ohms. The cores of antenna coils T201 through T206 are of different material, and the cores of tuning circuits Z206, Z212, and Z218 are larger in size. Capacitor C342 does not appear. Capacitor C221B (3 to 12  $\mu\text{mf}$ ) is connected between terminals 3 and 6 of T206.
- (3) Below MOD 3, capacitor C343 does not appear.

*c. Changes in Equipment According to Af Subchassis MOD Numbers.*

- (1) Below MOD 1, resistor R635 is not included.
- (2) Below MOD 2, capacitor C612 is not included; resistor R609 (18 ohms) is connected between the junction of resistors R608 and R604 and ground.

*d. Change in Equipment According to Gear Train Subchassis MOD Numbers.* Below MOD 1, the green-coded offset gear is mounted in reverse position with the green face toward the back, and the gears are not meshed with the clutch gear.

*e. Change to Equipment According to If Subchassis MOD Numbers.* Below MOD 1, resistor R558 is 1 megohm.

*f. Change in Equipment According to Crystal-oscillator Subchassis MOD Numbers.* Below MOD 1, capacitor C426 is 130  $\mu\text{mf}$ .

*g. Change in Equipment According to Vfo Subchassis MOD Numbers.* The vfo circuit is shown in figure 35 for equipment with numbers below MOD 1.

### 51. First Rf Amplifier V201

(fig. 28)

The first rf \* \* \* to 1-mc band.

*a. Grid bias for \* \* \* off the receiver. Capacitor C343 is connected between the agc line and ground to reduce radiation from the receiver. When the FUNCTION \* \* \* BY and OFF.*

\* \* \* \* \*

On figure 29, "R221 27" is changed to read:

**R221 68.**

On figure 30, "C307 1" is changed to read:

**C307 .75.**

"C310 1" is changed to read:

**C310 .75.**

Figure 35. Variable frequency oscillator for earlier models, schematic diagram.

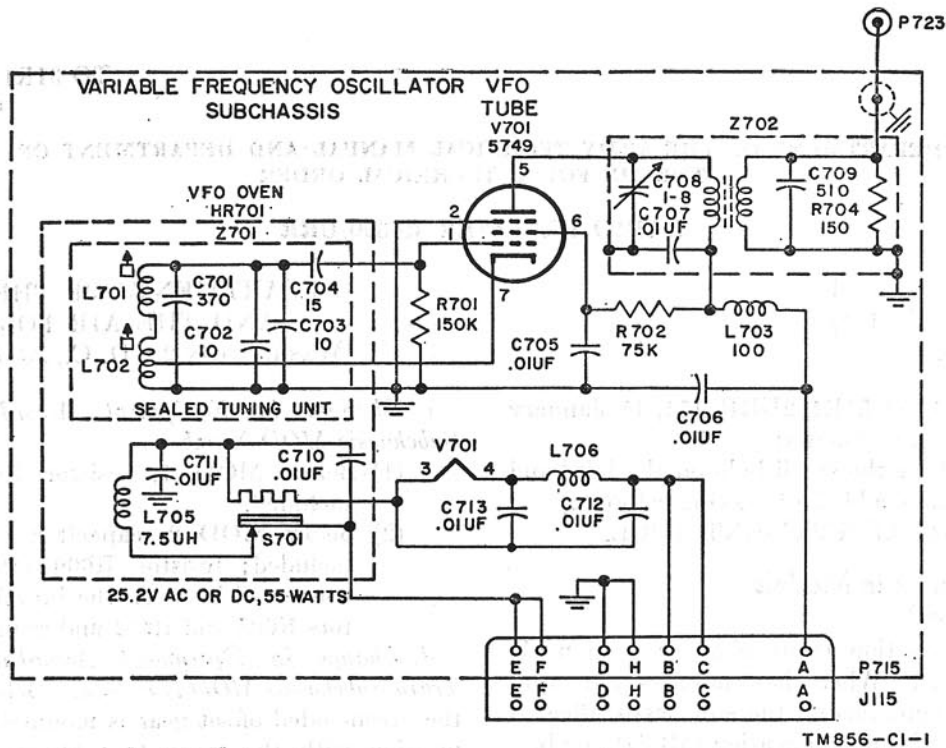

TM856-CI-1

Figure 35.1 (Added). Variable frequency oscillator, MOD 1 and higher, schematic diagram.

On figure 38:

NOTE 2 (Superseded). RESISTOR R519 IS 910 OHMS, R520 IS 5,100 OHMS, AND R521 IS 3,900 OHMS.

On figure 42, "C343 2,000" is added to the AGC LINE between terminal E of jack J214 and ground. "R558 1 MEG" is changed to read: **R558 1.2 MEG.**

On figure 46, R609 is deleted. The junction of R604 and R608 is connected to ground. C612 (8  $\mu$ f) is connected across R608.

## 71. Local Audio Channel

(fig. 46)

The local audio \* \* \* and frequency response.

\* \* \* \* \*

c. (Superseded) Harmonic distortion is reduced by a negative feed-back loop which uses resistors R606 and R604. Negative feed-back voltage is coupled from the plate of V603 back through R606 to the cathode of V602. This voltage is in proper phase to increase the signal voltage on the cathode. The cathode voltage opposes the input voltage on the grid and in effect reduces the gain of the two audio-frequency stages. This negative feedback not only reduces distortion, but reduces the output impedance of the amplifier which provides more stable operation.

On figure 75, Resistor R609 is deleted. Capacitor C612 is added to terminal board TB601 and is connected across resistor R608 on the opposite side of the board.

On figure 82, the following note is added:

8. VARIATION IN VALUES MAY BE CAUSED BY CHANGE IN CIRCUITS. REFER TO PARAGRAPH 13.1.

On figure 83, the following note and table are added:

8. VARIATION IN VALUES MAY BE CAUSED BY CHANGE IN CIRCUITS. REFER TO PARAGRAPH 13.1.

RESISTANCE AND VOLTAGE TABLE FOR VFO TUBE V701

(VFO SUBCHASSIS MOD 1 AND HIGHER)

Pin No.	Voltage	Resistance
1	-1 TO -2.3	150K.
2	0	0.
3	0	0.
4	5.7 AC	3.
5	178	8,500.
6	60	85K.
7	0	0.

Figure 84. The following note is added:

9. VARIATION IN VALUES MAY BE CAUSED BY CHANGE IN CIRCUITS. REFER TO PARAGRAPH 13.1.

### 105. Removals and Replacements

Directions for removing \* \* \* in the head.

\* \* \* \* \*

r. Replacement of Rf Tuning Coils and Transformers. To replace the \* \* \* in q above. Beginning with rf subchassis MOD 2, the cores of antenna coils T201 through T206 are made of different material to improve tracking. The cores of tuning circuits Z206, Z212, and Z218 are smaller in size to increase the tuning range of the high-frequency band. Coils or transformers that have identical functions are interchangeable for all models, providing the change is complete with tuning cores. However, when a tuning core is replaced the correct one of the two types available must be selected for proper operation of the coil.

\* \* \* \* \*

On figures 107 and 108, the following changes are made:

"R221 27" is changed to read: **R221 68.**

"R558 1 MEG" is changed to read: **R558 1.2 MEG.**

"R203 100" is changed to read: **R203 220.**  
Resistor R609 is deleted and the junction of R604 and R608 is connected to ground.

"C612 8" is connected across R608.

"C207 22" is changed to read: **C207 150.**

"C248 24" is changed to read: **C248 27.**

"C271 24" is changed to read: **C217 27.**

"C302 24" is changed to read: **C302 27.**

"C249 56" is changed to read: **C249 51.**

"C272 56" is changed to read: **C272 51.**

"C303 56" is changed to read: **C303 51.**

"C274 510" is changed to read: **C274 330.**

"C307 1" is changed to read: **C307 .75.**

"C310 1" is changed to read: **C310 .75.**

"C289 68" is changed to read: **C289 39.**

Capacitor C221B is disconnected from terminal 5 and is connected to terminal 6 of T206, directly across the secondary winding.

"C221B 3-12" is changed to read: **C221B 1.5-7.**

"C342 24" is added and is connected from terminal 3 to terminal 5 of T206.

"C426 120" is changed to read: **C426 150.**

Note 3. (Superseded) R519 VALUE, 910 OHMS.

R520 VALUE, 5,100 OHMS.

R521 VALUE, 3,900 OHMS.

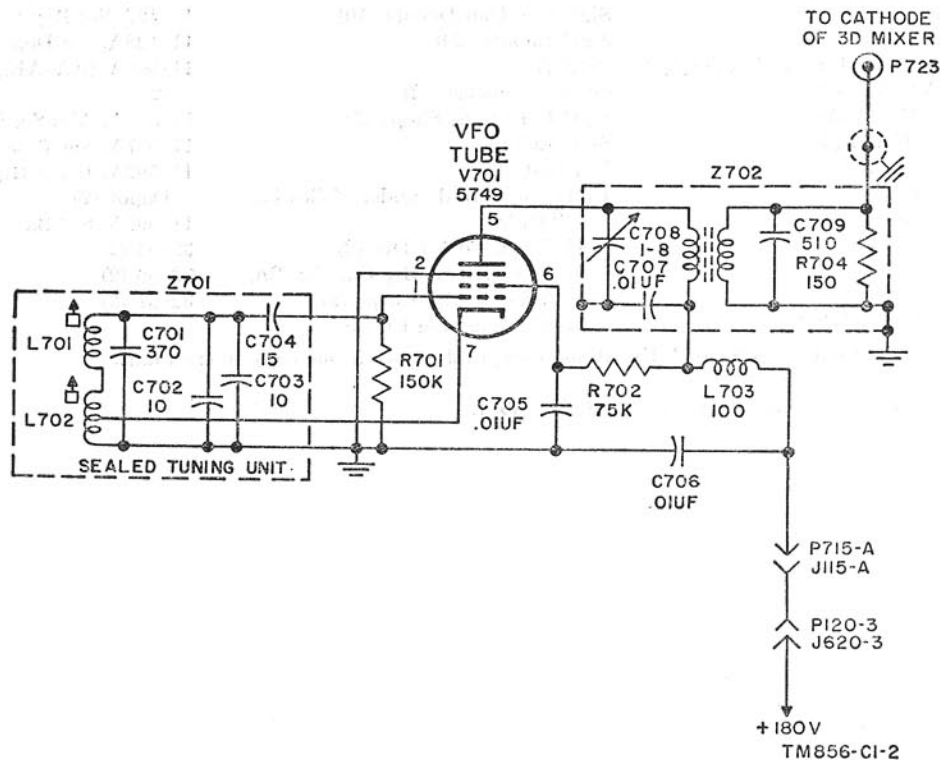

Figure 107.1 (Added). Vfo subchassis, MOD 1 and higher, schematic diagram.

R561 SELECTED AT TEST-RANGE  
VALUES 560 to 5,600 OHMS.

On figure 107, the frequency of Y417 is changed  
from 11.666 to 10.666.

The following note is added:

9. VFO SUBCHASSIS SHOWN IN FOR  
EQUIPMENT BELOW MOD 1. RE-  
FER TO FIGURE 107.1 FOR LATEST  
CIRCUIT.

On figure 108, the following note is added:

- VFO SUBCHASSIS SHOWN IS FOR  
EQUIPMENT BELOW MOD 1. RE-

FER TO FIGURE 107.1 FOR LATEST  
CIRCUIT.

### 118. Adjustment of GAIN ADJ Potentiometer R562

\* \* \* \* \*  
b. Connect RF Signal Generator Set AN/  
URM-25 or equivalent between J525 and the  
receiver ground (chassis). Turn on the \* \* \*  
150 microvolts ( $\mu$ v).

\* \* \* \* \*  
[AG 413.44 (24 May 55)]

BY ORDER OF THE SECRETARY OF THE ARMY:

M. B. RIDGWAY,  
General, United States Army,  
Chief of Staff.

OFFICIAL:

JOHN A. KLEIN,  
Major General, United States Army,  
The Adjutant General.

DISTRIBUTION:

Active Army:

CNGB (1)  
Tec Svc, DA (1)  
Tec Svc Bd (1)  
CONARC (5)  
CONARC Bd (Incl ea Test Sec) (1)  
Army AA Comd (2)  
OS Maj Comd (5)  
OS Base Comd (5)  
Log Comd (5)  
MDW (1)  
Armies (5)  
Corps (2)  
Tng Div (2)  
Ft & Cp (2)  
Gen & Br Svc Sch (5)

SigC Sch (25)  
Gen Depots (2)  
SigC Sec, Gen Depots (10)  
SigC Depots (20)  
POE (2)  
OS Sup Agencies (2)  
SigC Fld Maint Shops (3)  
SigC Lab (5)  
Mil Dist (1)  
Units organized under following  
TOE's:  
11-7, Sig Co Inf Div (2)  
11-16A, Hq & Hq Co, Sig Bn,  
Corps or Abn Corps (2)  
11-57, Armd Sig Co (2)

Units organized under following  
TOE's—Continued  
11-127, Sig Rep Co (2)  
11-128A, Sig Depot Co (2)  
11-500A (AA-AE), Sig Svc Org  
(2)  
11-557A, Abn Sig Co (2)  
11-587A, Sig Base Maint Co (2)  
11-592A, Hq & Hq Co, Sig Base  
Depot (2)  
11-597A, Sig Base Depot Co (2)  
32-55 (2)  
32-56 (2)  
32-57 (2)

NG: State AG (6); units—same as Active Army except allowance is one copy to each unit.

USAR: None.

For explanation of abbreviations used, see SR 320-50-1.

DEPARTMENT OF THE ARMY TECHNICAL MANUAL  
DEPARTMENT OF THE AIR FORCE TECHNICAL ORDER  
RADIO RECEIVER R-390/URR

TM 11-856  
TO 31R1-2URR-154  
CHANGES No. 2

TM 11-856/TO 31R1-2URR-154, 11 January 1955, is changed as follows:

8. Description of Radio Receiver R-390/URR

\* \* \* \* \*  
d. Radio Receiver R-390/URR \* \* \* seven removable subchassis. During production of the receivers, many changes were made to the individual subchassis and the receivers. Each subchassis affected is stamped with a modification (MOD) number. Refer to paragraph 13.1 for the differences in models. The rf subchassis \* \* \* hand tools only.

10. Description of Power Supply PP-621/URR (AC Power Supply)  
(fig. 16)

Power Supply PP-621/URR \* \* \* or 230-volt operation. Power Supplies PP-621/URR marked with MOD numbers are not interchangeable with the power supplies that are not so marked because a change has been made in the circuit that contains fuse F102.

13.1 Differences in Models

During production many \* \* \* the earlier equipment.

\* \* \* \* \*  
b. Changes in Equipment According to RF Sub-Chassis MOD Numbers.

\* \* \* \* \*  
(4) (Added) Below MOD 4, capacitor C344 does not appear.

\* \* \* \* \*  
f. Change in Equipment According to Crystal-Oscillator Subchassis MOD Numbers.

(1) Below MOD 1, capacitor C426 is 130  $\mu$ f.

DEPARTMENTS OF THE ARMY AND  
THE AIR FORCE  
WASHINGTON 25, D. C., 29 September 1955

(2) (Added) Below MOD 2, capacitors C439 and C440 do not appear.

\* \* \* \* \*  
h. (Added) Changes in Equipment According to Power Supply PP-621/URR MOD Numbers.

- (1) Below MOD 1, fuse F102 (B+  $\frac{3}{8}$  amperes) is connected in the line between contact P120-5 and the positive terminal of capacitor C101.
- (2) Below MOD 1, the center-tap terminal (6) of transformer T801 is connected directly to ground.
- (3) Below MOD 1, contacts 10 and 12 of jack J818 are connected by a jumper.
- (4) Below MOD 1, the line labeled 3 MF (93), connecting terminal 12 of plug P118 to fuse F102, does not appear; and the other side of the fuse does not connect to the junction of capacitor C101 and the line labeled P118-13 PS (9) 6.

54. First Crystal Oscillator V401  
(fig. 31).

The first crystal \* \* \* the resonant circuit.  
a. Bias is developed \* \* \* R403 and C403. Additional filtering is provided by L406, C436, and C440.

\* \* \* \* \*  
Figures 31 and 33. Capacitor C440 is added between contact A of jack J413 and chassis ground.

56. Second Crystal Oscillator V402  
(fig. 33)

The second crystal \* \* \* the grid circuit.  
a. Bias is developed \* \* \* R407 and C407. Additional filtering is provided by L406, C440, and C436.

\* \* \* \* \*

## 77. Power Circuits

The power circuits \* \* \* positions except OFF.  
a. *Power Supply PP-621/URR* (fig. 52).

\* \* \* \* \*

- (2) The ends of \* \* \* V801 and V802. The center tap of transformer T801 (terminal 6) is grounded **through fuse F102**. The tubes, V801 \* \* \* voltage regulator circuits.

b. *Voltage Regulator* (fig. 53). The voltage regulator \* \* \* the input voltage. The output from the power supply is fed to the voltage regulator. The voltage-regulator circuit \* \* \* in the output.

c. *Filament and Oven Heater Circuits* (fig. 54). Filament voltages of \* \* \* in series circuits. To prevent interstage coupling of high-frequency signals through the filament circuits, the following capacitor and choke coil combinations are used: L242, C344, and C326; L243 and C327; L244, C328, and C329; L245, C330, and C331; L247, C332, and C340; L403, C437, and C410; L404 and C412; L405, C413, and C439; and L706, C712, and C713. Limiting resistor R411 \* \* \* the audio subchassis.

Figures 52 and 53. Fuse F102 (B+ $\frac{1}{2}$  amperes) is deleted from its present position. The contact of P118-5 is connected to the junction of C101 and P120-5. The ground connection of terminal 6 on transformer T801 is deleted. Terminal 6 is connected through contacts J818-12 and P118-12 and fuse F102 (B+ $\frac{1}{2}$  amperes) to ground.

Figure 54. Capacitor C344 is added between contact F of jack J214 and chassis ground.

Capacitor C436 (2,000  $\mu\mu\text{f}$ ) is deleted and replaced by C439 (5,000  $\mu\mu\text{f}$ ).

Capacitor C439 is connected between contact B of jack J413 and chassis ground.

Figure 98. Fuse F102 (B+ $\frac{1}{2}$  amperes) is deleted.

Figure 107. The following changes are made in figure 107.

Capacitor C344 (5,000  $\mu\mu\text{f}$ ) is added and [AG 413.44 (15 Aug 55)]

connected between contact F of jack J214 and chassis ground.

Capacitor C440 (5,000  $\mu\mu\text{f}$ ) is added and connected between contact A of jack J413 and chassis ground.

Capacitor C436 (2,000  $\mu\mu\text{f}$ ) is deleted and replaced by capacitor C439 (5,000  $\mu\mu\text{f}$ ). C439 is connected between contact B of jack J413 and chassis ground.

The jumper is removed that connects contacts 10 and 12 of jack J818.

Terminal 6 of transformer T801 is disconnected from chassis ground and connected to terminal 12 of jack J818.

The wires labeled P118-5 PS (92) 4 and P120-5 AF (923) 5, (connected to fuse F102) are removed from fuse F102 and connected to the terminal of capacitor C101 that was formerly connected to the fuse.

Terminal 12 of plug P118 is connected to the wiring channel with an additional line labeled 3 MF (93). The other end of this wire is labeled P118-12 PS (93) 3, and connected to one terminal of fuse F102.

The other terminal of fuse F102 is connected to the junction of capacitor C101 and the line labeled P118-13 PS (9) 6.

Figure 108. The following changes are made in figure 108.

Capacitor C344 (5,000  $\mu\mu\text{f}$ ) is added between contact F of jack J214 and chassis ground.

Capacitor C440 (5,000  $\mu\mu\text{f}$ ) is added between contact A of jack J413 and chassis ground.

The reference symbol for capacitor C436 and its value (2,000  $\mu\mu\text{f}$ ) are changed to read: C439 (5,000  $\mu\mu\text{f}$ ). C439 is connected between contact B of jack J413 and chassis ground. Fuse F102 is deleted from its present position, and wire P118-5 is connected directly to C101 and P120-5.

The ground connection at terminal 6 of transformer T801 is deleted. Terminal 6 of transformer T801 is connected to fuse F102 (B+ $\frac{3}{8}$  amperes) through contacts J818-12 and P118-12. The other side of the fuse is grounded.



BY ORDER OF THE SECRETARIES OF THE ARMY AND THE AIR FORCE:

MAXWELL D. TAYLOR,  
General, United States Army,  
Chief of Staff.

OFFICIAL:

JOHN A. KLEIN,  
Major General, United States Army,  
The Adjutant General.

N. F. TWINING,  
Chief of Staff, United States Air Force.

OFFICIAL:

E. E. TORO,  
Colonel, United States Air Force,  
Air Adjutant General.

DISTRIBUTION:

Active Army:

CNGB (1)  
Tec Svc, DA (1) except CSIGO (30)  
Tec Svc Bd (1)  
Hq CONARC (5)  
CONARC Bd (incl ea Test Sec) (1)  
Army AA Comd (2)  
OS Maj Comd (5)  
OS Base Comd (5)  
Log Comd (5)  
MDW (1)  
Armies (5)  
Corps (2)  
Tng Div (2)  
Ft & Cp (2)  
Gen & Br Svc Sch (5) except Sig  
Sch (25)

Gen Depots (2) except Atlanta Gen  
Depot (None)  
Sig Sec, Gen Depots (10)  
Sig Depots (20)  
POE (2)  
OS Sup Agencies (2)  
Sig Fld Maint Shops (3)  
Sig Lab (5)  
Mil Dist (1)  
Units organized under following  
TOE's:  
11-7R, Sig Co, Inf Div (2)  
11-16R, Hq & Hq Co, Sig Bn,  
Corps or Abn Corps (2)  
11-57R, Armd Sig Co (2)  
11-127R, Sig Rep Co (2)

11-128R, Sig Depot Co (2)  
11-500R (AA-AE), Sig Svc Org  
(2)  
11-557R, Abn Sig Co (2)  
11-587R, Sig Base Maint Co (2)  
11-592R, Hq & Hq Co, Sig Base  
Depot (2)  
11-597R, Sig Base Depot Co (2)  
32-51R, Hq & Hq Co, Comm  
Recon Gp (2)  
32-55R, Comm Recon Bn (2)  
32-56R, Hq & Hq Co, Comm  
Recon Bn (2)  
32-57R, Comm Recon Opr Co  
(2)

NG: State AG (6); units—same as Active Army except allowance is one copy to each unit.

USAR: None.

For explanation of abbreviations used, see SR 320-50-1.

RADIO RECEIVER R-390/URR

TM 11-856  
To 31R1-2URR-154 }  
CHANGES No. 4 }

DEPARTMENTS OF THE ARMY  
AND THE AIR FORCE  
WASHINGTON 25, D. C., 22 December 1958

TM 11-856/TO 31R1-2URR-154, 11 January 1955, is changed as follows:

*Note.* A parenthetical reference to previous Changes (example: "page 1 of C 2") indicates that pertinent material was published in that Changes.

Add the following note in the places indicated below:

NOTE:

IN RECEIVERS MODIFIED BY MWO 11-5820-294-35/1, THE WIRES CONNECTED TO B +  $\frac{3}{8}$ A FUSE F102 ARE REMOVED AND TIED TOGETHER, AND THE GROUND CONNECTION ON TRANSFORMER T801 IS REMOVED. THERE IS NO CONNECTION BETWEEN THE DC 20A FUSE F103 AND P118-15 (NOT APPLICABLE TO FIGURE 53), AND TERMINAL 6 OF T801 IS CONNECTED THROUGH THE CONTACTS OF J818-15 AND P118-15 AND B +  $\frac{3}{8}$ A FUSE F102 TO GROUND. THE B +  $\frac{3}{8}$ A FUSE IS CALLED THE HV $\frac{3}{8}$ A FUSE.

Page 74, figure 53.

Page 75, figure 52.

Figure 107 (part 1).

Figure 108 (part 2).

Page 11, paragraph 10 (page 1 of C 2). Add the following after the last sentence: Power Supplies PP-621/URR modified in accordance with MWO 11-5820-294-35/1 are not interchangeable with power supplies that are not so marked because of wiring changes in the B +  $\frac{3}{8}$ A fuse F102 circuit.

Page 15, paragraph 13.1 (page 1 of C 2). Add the following after subparagraph *h*:

*i. Changes in Equipment According to MWO.* Radio Receivers R-390/URR modified by MWO 11-5820-294-35/1 have the former B +  $\frac{3}{8}$ A fuse F102 in the ground lead of power transformer T801 and the name of the fuse is changed to HV  $\frac{3}{8}$ A. The MWO supersedes MWO SIG 191 dated 20 July 1955 and contractor changes on Power Supplies PP-621/URR identified as MOD 1 and above. These changes restore interchangeability between

Power Supplies PP-621/URR and permit their being used in all Radio Receivers R-389/URR, R-390/URR, and R-391/URR so modified.

Page 18, paragraph 16. Add subparagraph *c* after subparagraph *b*.

*c. Reducing Surrounding Temperature of Receivers and Tubes.*

- (1) When receivers are protected from dust by a cabinet, the dust covers should be removed to increase ventilation. Replace the screws and lock-washers that hold the dust covers in their positions so that they are available when the dust covers are re-installed.
- (2) When receivers are used in fixed stations, remove all tube shields from the 6BJ6 type tubes located in the RF and IF amplifier subchassis and from the rectifier type 25Z5W tubes in the power supply subchassis.
- (3) Securely wrap the tube shields and dust covers. Mark the nomenclature and serial number of the receiver from which they were removed on the cover of the package. Store them for future use. Reinstall the tube shields and dust covers when the receivers are stored or shipped.

Page 26.

25.1. Reception of Single-Sideband Signals  
(Added)

Tuning the receiver for reception of single-sideband signals must be done accurately. The procedure for tuning the receiver to single-sideband voice signals is given below.

*Note.* This procedure may be used for single-sideband reception of am double-sideband signals when interference and distortion are caused by selective fading. Tune to either the upper or lower sideband.

a. Calibrate the receiver at the 100-kc calibration point nearest the single-sideband signal to be received. (par. 26).

b. Set the FUNCTION switch to MGC.

c. Set the RF GAIN control to 5.

d. Set the LOCAL GAIN control between 5 and 10.

e. Set the BANDWIDTH switch to 2 KC.

f. Turn the BFO switch to ON.

g. Set the BFO PITCH control to  $-1$  for upper sideband reception or  $+1$  for lower sideband reception.

h. Tune to the frequency of the desired signal;  $+1$  kc if the upper sideband is used and  $-1$  kc if the lower sideband is used.

i. If a BANDWIDTH switch setting of 4 kc is to be used, double the  $-1$  or  $+1$  setting (*g* and *h* above).

j. Adjust the BFO PITCH and/or KILOCYCLE CHANGE controls slightly for the most intelligible signal reception.

k. Adjust the LOCAL GAIN and RF GAIN controls for the desired audio level.

Page 34.

#### 42.1. Checking Receiver Performance With Noise (Added)

An effective method of checking receiver performance and determining in which subchassis possible causes of trouble exist is to perform certain operations while listening to the noise produced by the receiver. Perform the operations in *a* through *e* below with the antenna disconnected from the receiver. Adjust the controls to produce audible noise in the loudspeaker or headset. Set the FUNCTION switch at MGC, the BANDWIDTH switch at 16 KC, and the BFO switch at OFF.

a. *AF Noise Test.* While listening to the noise, ground the DIODE LOAD terminal on the rear panel (terminal 14). Terminal 16 is a convenient ground connection. The noise should be greatly reduced. Make the same check while listening to the remote audio output or watching the LINE LEVEL meter. If the noise at both audio outputs almost disappears when the DIODE LOAD terminal is grounded, the audio circuits may be considered to be operating properly. If only the local output is reduced,

check tubes V602 and V604 and the seating of connector P119 (fig. 88). If neither output is affected, check tubes V507 and V601. If tube replacement is not effective, trouble shoot the af subchassis at a field maintenance level.

b. *IF Noise Test.* Set the BANDWIDTH switch at 16 KC. With the other controls set for audible noise, set the BANDWIDTH switch successively at each lower position while listening to the noise. The noise should decrease at each position, until it can hardly be heard in the .1 KC position. If there is little or no change in noise output as the switch is rotated, check tubes V501 through V504. If the tubes are not defective, further trouble shooting of the IF subchassis at a field maintenance level will be necessary.

c. *Noise at Grid Test Points.* Set the multimeter to the highest resistance range. Connect one multimeter lead to the chassis and, in turn, touch the prod on the other lead to grid test points E210, E209, E208, E207, and E206, in that order (fig. 62). A click should be heard each time the prod touches the test point. If no click is heard, check the tube closest to the check point. Be sure that all connectors are seated firmly in their receptacles.

d. *RF Tuner Noise Test.* Starting with the megacycle frequency indicator at 02, turn the MEGACYCLE CHANGE control through its range to the highest frequency, while listening to the noise in the headset or loudspeaker. There should be a sharp and pronounced increase in noise as the control is seated in each detent position. Across the tuning range, some adjustment of the ANT TRIM control will be necessary to produce maximum noise. Between detent settings, the noise should show a pronounced drop in level. From one detent to the next (except between the settings where RF coil ranges are to be switched), the noise level should be almost constant. RF coils are switched between the following settings: 03 and 04, 07 and 08, 15 and 16. If noise at any point across the range is not maximum with the knob in the detent position, mistracking at that point is possible. Adjustment at a field maintenance level is required. The RF and variable IF alignment should be checked (pars. 114, 115, and 116). If the noise does not drop between detent settings, check for excessive IF gain (par. 118). If noise is less at one detent setting, check the

over-all gain (par. 117.1) and the adjustment of the crystal-oscillator trimmer capacitors (pars. 112 and 113).

*e. Antenna Circuit Noise Tests.* Rotate the ANT TRIM control. The noise should peak at one particular point. Ground the center contact of the ANTENNA UNBALANCED WHIP connector J107. A click should be heard and the noise should drop sharply. Ground both contacts of the BALANCED 125 OHM connector J108. A click should be heard and the noise drop sharply. If the receiver does not pass these tests, check the antenna relay, the connectors on the antenna relay box, and the sections of the RF band change switch that connect to transformers T201 through T206.

*Page 35, paragraph 43b(2).* Add the following after the last sentence:

If the output of the calibration oscillator is unstable or there is frequent tube failure, change the 12AU7 tubes to type 5814A tubes.

*Page 40, paragraph 47.* Normal indications column, line 34. Change "of" to: af.

*Page 46, figure 30.* Add a ground symbol to cathode resistor R404. Delete the connection drawn between the ground end of R404 and jack J421.

*Page 47, paragraph 55, line 5.* Change "36-mc" to: 32-mc.

*Page 48, figure 32.* Add a ground symbol to cathode resistor R408.

*Face page 84, figure 61.* Add reference symbols to the AMPHENOL connectors as shown in the following chart:

Cable No.	AMPHENOL	Ref symbol
8	26-806	J517
8	26-807	P117
3	26-150	P119
3	26-151	J619
4	26-804	J620
4	26-805	P120
5	26-150	P118
5	26-151	J818
6	26-192	P113
6	26-1059	J413
7	26-1059	P715
7	26-192	J115
2	26-192	P114
2	26-1059	J214

*Page 88, paragraph 92,* Correction column, line 10. Add the following after line 10: Substitute tube type 5814A for defective tube type 12AU7 in V901 and V902.

*Page 90, figure 63.* Delete reference symbol "J323" and substitute: J223.

*Page 90, figure 64.* Delete reference symbol "S208" (next to S210) and substitute: S209.

*Page 107, paragraph 105c(1).* Add the following to subparagraph (1):

In early production models of the receiver the green-coded offset gear is merely reversed to mesh with the gear train.

*Page 108, paragraph 105d.*

(10.1) (Added) Tighten the rear right green mounting screw.

Subparagraph (13), line 1. Add the following after "offset": gear.

Subparagraph (13). Add the following: In early production models of the receiver, the green-coded offset gear is reversed to disengage from the RF gear train.

*Page 112.*

### 105.1. Disassembly of RF Gear Train Assembly (Added)

*a. General.* Under certain circumstances, such as extensive damage or mechanical failure of a component, it may be necessary to disassemble all or part of the RF gear train assembly. The instructions given in this paragraph should be used as a guide when the method of removal of parts is not obvious. The index numbers used in the instructions refer to those that identify the parts in figure 88.1. When disassembling the RF gear train assembly, mark the individual gears with the index number. This will aid identification and reassembly. Place the parts in trays or containers in the order of disassembly. This will simplify reassembly.

*b. Disassembly.*

- (1) Remove the front panel (par. 105a).
- (2) Remove the RF subchassis (par. 105c).
- (3) Remove the 8 slug racks and the 16 tension springs. Tag the slug racks for identification according to frequency.

- (4) Loosen the  $\frac{5}{16}$ -inch hexagonal nut (1) and  $\frac{5}{16}$ -inch lock washer (2) and remove the 6-32 by  $\frac{5}{16}$ -inch Phillips head screw (3) and the No. 6 lockwasher (4). Remove the clutch gear assembly. Remove the  $\frac{5}{16}$ -inch hexagonal nut (1) and  $\frac{5}{16}$ -inch lockwasher (2). To disassemble the clutch gear assembly, follow the procedures in (a) and (b) below. If it is not necessary to disassemble the clutch gear, proceed with (5) below.
  - (a) Remove the .395-inch retaining ring (5), split gear assembly (6),  $\frac{7}{16}$ -inch flat washer (7), four  $1\frac{7}{32}$ -inch spring friction washers (8), two  $\frac{7}{16}$ -inch flat washers (9), steel plate (10), four clutch plates (11), and brass gear (12).
  - (b) Remove the zero adjust shaft (13), the .225-inch retaining ring (14), stop washer (15), spring holder (16), stop spring (17), flat pin (18),  $\frac{1}{4}$ -inch washer (19), .225-inch retaining ring (20), steel bushing (21), from the clutch assembly shaft (22).
- (5) Remove the four 4-40 by  $\frac{5}{16}$ -inch Phillips head screws (23) and four No. 4 split lockwashers (24) to remove the mechanical counter (25).
- (6) Remove the beveled gear (26) and gear clamp (27) by loosening the 3-56 by  $\frac{1}{4}$ -inch Bristo head screw (28).
- (7) Remove the beveled gear (29) and gear clamp (30) by loosening the 3-56 by  $\frac{1}{4}$ -inch Bristo head screw (31).
- (8) Remove the two beveled gear assemblies (32) and (33).
- (9) Remove the 6-32 by  $\frac{3}{16}$ -inch Phillips head screw (34) and No. 6 lockwasher (35) and green-faced gear (36).
- (10) Remove the .207-inch retaining ring (37) and the brass gear (38).
- (11) Remove the .207-inch retaining ring (39) and remove the hollow pin (40) from brass gear (41). Pull out the gear and shaft assembly (42) while sliding off gear (41) and  $\frac{3}{16}$ -inch washer (43).
- (12) Remove the 6-40 by  $\frac{5}{16}$ -inch machine screw (44).
- (13) Remove the front plate assembly (45) by removing the three 8-32 by  $\frac{5}{16}$ -inch Phillips head screws (46) and the three No. 8 lockwashers (47).
- (14) Remove the .225-inch retaining ring (48) and pull out the welded gear and shaft assembly (49) from the rear of the front plate assembly (45).
- (15) Remove the .122-inch retaining ring (50) to remove the large brass gear (51).
- (16) Remove the three 6-32 by  $\frac{1}{4}$ -inch Phillips head screws (52) and the three No. 6 lockwashers (53) that hold the triangular steel plate (54) to the front plate assembly (45).
- (17) Remove the .122-inch retaining ring (55) and remove the pinned gear assembly (56) and  $\frac{5}{16}$ -inch washer (57).
- (18) Remove the two 6-32 by  $\frac{1}{4}$ -inch Phillips head screws (58) and the two No. 6 lockwashers (59) holding the detent spring (60).
- (19) Remove the differential gear assembly (61) through (72). To disassemble the differential gear assembly, follow the procedures given in (a) through (e) below. If it is not necessary to disassemble the differential gear, proceed with (20) below.
  - (a) Remove the three 4-40 by  $\frac{1}{4}$ -inch Phillips head screws (61) and the three No. 4 lockwashers (62).
  - (b) Gently lift off the pinned gear assembly (63).
  - (c) Remove the three .122-inch retaining rings (64) and remove the three identical brass split gear assemblies (65).
 

*Note.* The third brass gear assembly is shown exploded with index numbers (66) through (69) in figure 88.1.
  - (d) Remove the .395-inch retaining ring (66) and separate the flat brass gear (67), the steel loading spring (68), and the pinned brass and steel gear assembly (69).

- (e) Remove the .395-inch retaining ring (70) to facilitate the removal of loading springs (71) on pinned gear and detent assembly (72).
- (20) Remove the pinned split gear assembly (73) and  $\frac{3}{16}$ -inch washer (74).
  - (21) Remove the steel split gear assembly (76) through (79),  $\frac{3}{16}$ -inch steel washer (75) and dismantle by removing the  $\frac{3}{16}$ -inch retaining ring (76) that separates steel gear (77), separator (78), and steel gear (79).
  - (22) Remove the .281-inch retaining ring (80) to remove the large brass gear assembly (81).
  - (23) Remove the large brass gear (82) by loosening the 4-40 by  $\frac{1}{16}$ -inch Bristo head screw (83) and the 4-40 square nut (84) on gear clamp (85).
  - (24) Remove the small steel gear (86) by loosening the 4-40 by  $\frac{1}{16}$ -inch Bristo head screw (87) and the 4-40 square nut (88) on gear clamp (89).
  - (25) Remove the .122-inch retaining ring (90) to remove the brass gear (91).
  - (26) Loosen the 4-40 by  $\frac{1}{16}$ -inch Bristo head screw (92) and the 4-40 square nut (93) on the gear clamp (94) to remove the steel gear (95) and the steel split gears (96). To disassemble the split gears, remove the three 4-40 by  $\frac{1}{4}$ -inch Phillips head screws (97).
  - (27) Loosen the 4-40 by  $\frac{1}{16}$ -inch Bristo head screw (98) and the 4-40 square nut (99) on the gear clamp (100) to remove the steel gear (101) and the steel split gear (102).
  - (28) Loosen the 4-40 by  $\frac{1}{16}$ -inch Bristo head screw (103) and the 4-40 square nut (104) on the gear clamp (105) to remove the steel split gear (106).
  - (29) Loosen the 4-40 by  $\frac{1}{16}$ -inch Bristo head screw (107) and the 4-40 square nut (108) on the gear clamp (109) to remove the split gear (110) and the small steel gear (111).
  - (30) Remove the three 4-40 by  $\frac{1}{4}$ -inch Phillips head screws (112) to remove the split gear assembly (113).
  - (31) Remove the No. 6/0 taper pin (114) to remove the cam (115). Pull the shaft (116) out through the front of the RF subchassis and remove the cam and gear assembly (117) by removing the No. 6 taper pin (118).
  - (32) Loosen the 4-40 by  $\frac{1}{16}$ -inch Bristo head screw (119) and the 4-40 square nut (120) on the gear clamp (121) to remove the split gear (122).
  - (33) Loosen the 4-40 by  $\frac{1}{16}$ -inch Bristo head screw (123) and the 4-40 square nut (124) on the gear clamp (125) to remove the split gear (126).
  - (34) Remove the 8-32 by  $\frac{5}{16}$ -inch Phillips head screw (127) and the No. 8 lockwasher (128) to remove the Geneva system and overtravel coupler. Separate the gear assembly by removing the steel plate (129), steel ball (130), and 10-tooth lost motion gear (131). Remove the .122-inch retaining ring (132) and washer (133) to separate the brass gear (134) and shaft (135).
  - (35) Remove the 6-32 hexagonal nut (136) and No. 6 lockwasher (137). Remove the  $\frac{3}{32}$ -inch retaining ring (138) and separate the steel eight-tooth and four-tooth gear (139) and the shaft (140) from the rear plate (146).
  - (36) Remove the 6-32 by  $\frac{5}{16}$ -inch hexagonal head screw (141) and the No. 6 lockwasher (142). Remove the .122-inch retaining ring (143) and separate the brass gear (144) and steel shaft (145) from the rear plate (146).
  - (37) Remove the .225-inch retaining ring (147). Loosen the 4-40 by  $\frac{1}{16}$ -inch Bristo head screw (148) and 4-40 square nut (149) to loosen the gear clamp (150). Separate the shaft (151) from the gear (152).
  - (38) Remove the two 6-32 by  $\frac{3}{16}$ -inch Phillips head screws (153) and No. 6 lockwashers (154) to loosen the flange (155). Remove the shaft and gear assembly (156). Remove the hollow pin (157) to separate the Oldham coupler (158), flange (155), and  $\frac{3}{16}$ -inch washer (159) from the shaft and gear assembly (156).

- (39) Remove the No. 6/0 taper pin (160) and the cam (161). Remove the No. 6 taper pins (162) and (164) to loosen the cams (163) and (165). Remove the cam shaft (166). Remove the No. 6/0 taper pin (167) and the cam (168).
- (40) Remove the No. 6/0 taper pin (169) and the cam (170) to remove the cam shaft (171). Remove the No. 6/0 taper pin (172) and the cam (173).
- (41) Remove the No. 6/0 taper pin (174) and the cam and gear assembly (175) to remove the cam shaft (176). Remove the No. 6/0 taper pin (177) and the cam (178).
- (42) Remove the No. 6/0 taper pin (179) and the cam (180) to remove the cam shaft (181). Remove the No. 6/0 taper pin (182) and the cam (183).
- (43) Remove the No. 6/0 taper pin (184) and the cam (185) to remove the cam shaft (186). Remove the No. 6/0 taper pin (187) and the cam (188).
- (44) Remove the No. 6/0 taper pin (189) and the cam (190) to remove the cam shaft (191). Remove the No. 6/0 taper pin (192) and the cam (193).
- (45) Remove the No. 6/0 taper pin (194) and the cam (195) to remove the cam shaft (196). Remove the No. 6/0 taper pin (197) and the cam (198).
- (46) Loosen the four 8-32 by  $\frac{3}{32}$ -inch Bristo head screws (199) and remove the  $\frac{1}{4}$ -inch coupler (200) and the  $\frac{1}{4}$ -inch fiber shaft (201). Remove the  $\frac{3}{8}$ -32 hexagonal head nut (202),  $\frac{3}{8}$ -inch lockwasher (203),  $\frac{3}{8}$ -inch flat washer (204), and the  $\frac{3}{8}$ -inch fiber washer (205).
- (47) Remove the six 6-32 by  $\frac{3}{8}$ -inch Phillips head screws (206) and the six No. 6 lockwashers (207) that hold the three brackets (208) and the three rods (209) to the rear plate (146).
- (48) Remove the three 8-32 by  $\frac{3}{8}$ -inch hexagonal head screws (210) and the three No. 8 lockwashers (211).
- (49) Remove the three 8-32 by  $\frac{1}{4}$ -inch flat-head Phillips head screws (212) that hold the three separator rods (213).

- (50) Remove the two 8-32 by  $\frac{3}{8}$ -inch hexagonal head screws (214) and the two No. 8 lockwashers (215). Remove the 8-32 by  $\frac{1}{4}$ -inch flathead Phillips head screw (216) and the No. 8 lockwasher (217) to remove the RF subchassis rear plate (218).

## 105.2. Reassembly of RF Gear Train Assembly (Added)

*a. General.* Use the index numbers in figure 87.1 as a guide in reassembly. If there is any doubt as to the identification of a part, refer to the parts legend (par. 105.3).

### *b. Reassembly.*

- (1) Replace the RF subchassis rear plate (218) and secure it with the 8-32 by  $\frac{1}{4}$ -inch flathead Phillips head screw (216), the No. 8 lockwasher (217), the two 8-32 by  $\frac{3}{8}$ -inch hexagonal head screws (214) and two No. 8 lockwashers (215).
- (2) Replace the three separator rods (213) by inserting the three 8-32 by  $\frac{1}{4}$ -inch flathead Phillips head screw (212).
- (3) Replace the three 8-32 by  $\frac{3}{8}$ -inch hexagonal head screws (210) and No. 8 lockwashers (211).
- (4) Attach the three brackets (208) to the rear plate (146) and three rods (209); use the six 6-32 by  $\frac{3}{8}$ -inch Phillips head screws (206) and the six No. 6 lockwashers (207).
- (5) Replace the  $\frac{3}{8}$ -inch fiber washer (205),  $\frac{3}{8}$ -inch flat washer (204),  $\frac{3}{8}$ -inch lockwasher (203),  $\frac{3}{8}$ -32 hexagonal head nut (202),  $\frac{1}{4}$ -inch coupler (200), and the  $\frac{1}{4}$ -inch shaft (201), and tighten the four 8-32 by  $\frac{3}{32}$ -inch Bristo head setscrews (199).
- (6) Replace the cam (198) and insert the No. 6/0 taper pin (197). Replace the shaft (196), the cam (195), and insert the No. 6/0 taper pin (194).
- (7) Replace the cam (193) and insert the No. 6/0 taper pin (192). Replace the shaft (191), the cam (190), and insert the No. 6/0 taper pin (189).
- (8) Replace the cam (188) and insert the No. 6 taper pin (187). Replace the shaft (186), the cam (185), and insert the No. 6/0 taper pin (184).

- (9) Replace the cam (183) and insert the No. 6/0 taper pin (182). Replace the shaft (181), the cam (180), and insert the No. 6 taper pin (179).
  - (10) Replace the cam (178) and insert the No. 6/0 taper pin (177). Replace the shaft (176), the cam and gear assembly (175), and insert the No. 6/0 taper pin (174).
  - (11) Replace the cam (173) and insert the No. 6/0 taper pin (172). Replace the shaft (171), and cam (170), and insert the No. 6 taper pin (169).
  - (12) Replace the cam (168) and insert the No. 6/0 taper pin (167). Replace the shaft (166) through the back panel (218). Replace the cam (165) when the shaft barely protrudes through the back panel (218), and replace the other cam (163) when the shaft is close to the other panel (146). Insert the No. 6/0 taper pins (164) and (162). Replace the cam (161) and insert the No. 6/0 taper pin (160).
  - (13) Replace the  $\frac{3}{16}$ -inch washer (159), the flange (155), and the Oldham coupler (158) on the shaft and gear assembly (156). Insert the hollow pin (157). Replace the shaft and gear assembly (156) in the RF subchassis. Replace the two 6-32 by  $\frac{3}{16}$ -inch Phillips head screws (153), and the No. 6 lockwashers (154), through the flange (155), and tighten to subchassis.
  - (14) Replace the gear (152) on the shaft (151). Tighten the 4-40 by  $\frac{5}{16}$ -inch Bristo head screw (148) and 4-40 square nut (149) on gear clamp (150). Replace the .225-inch retaining ring (147).
  - (15) Replace the gear (144) on the shaft (145) and fasten with the .122-inch retaining ring (143). Position this assembly on rear plate (146) as shown in figure 87.1. Fasten it to the plate (146) with the 6-32 by  $\frac{5}{16}$ -inch hexagonal head screw (141) and the No. 6 lockwasher (142).
  - (16) Replace the gear (139) on the shaft (140) and fasten it with the  $\frac{3}{32}$ -inch retaining ring (138). Position this assembly as shown in figure 87.1 and fasten it with the 6-32 hexagonal nut (136) and the No. 6 lockwasher (137).
  - (17) Place the brass gear (134) on the shaft (135). Replace the washer (133) and the .122-inch retaining ring (132). Replace the 10-tooth lost motion gear (131) on the shaft (135). Replace the steel ball (130) and plate (129). Replace the assembly on the rear plate (146) (fig. 88.1) and fasten it with the 8-32 by  $\frac{5}{16}$ -inch Phillips head screw (127) and the No. 8 lockwasher (128).
- Note.* Be sure that the alinement is precise so that this assembly will function correctly.
- (18) Assemble the gear clamp (125) and split gear (126). Load two teeth on the split gear (126) while placing it on the shaft (171) to mesh with the gear (175). Tighten the 4-40 by  $\frac{5}{16}$ -inch Bristo head screw (123) and 4-40 square nut (124).
  - (19) Assemble the gear clamp (121) and split gear (122). Place the assembly on the shaft (166) and tighten the 4-40 by  $\frac{5}{16}$ -inch Bristo head screw (119) and 4-40 square nut (120).
  - (20) Place the gear and cam assembly (117) on the shaft (116), insert the No. 6/0-taper pin (118). Replace the shaft (116), the cam (115), and the No. 6/0 taper pin (114).
  - (21) Place the split gear assembly (113) on the gear and cam assembly (175) and fasten it with the three 4-40 by  $\frac{1}{4}$ -inch Phillips head screws (112).
  - (22) Place the gear clamp (109) on the gear (111) and place the gear (111) on the split gear (110). Place this assembly on the shaft (186) and tighten the 4-40 by  $\frac{5}{16}$ -inch Bristo head screw (107) and 4-40 square nut (108).
  - (23) Place the gear clamp (105) on the split gear (106) and place the assembly on the shaft (196). Tighten the 4-40 by  $\frac{5}{16}$ -inch Bristo head screw (103) and 4-40 square nut (104).
  - (24) Place the gear clamp (100) on the gear (101) and place this assembly on the split gear (102). Place this assem-



- on the shaft (191) while loading the split gear (106) by two teeth. Tighten the 4-40 by  $\frac{3}{16}$ -inch Bristo head screw (98) and 4-40 square nut (99) on the gear clamp (100).
- (25) Fasten the split gear (96) to the steel gear (95) with the three 4-40 by  $\frac{1}{4}$ -inch Phillips head screws (97). Place the gear clamp (94) on the gear (95) and place the whole assembly on the shaft (181) while loading two teeth on the split gears (96) and (113). Tighten the 4-40 by  $\frac{3}{16}$ -inch Bristo head screw (92) and 4-40 square nut (93).
  - (26) Replace the brass gear (91) and the .122-inch retaining ring (90).
  - (27) Place the gear clamp (89) on the small steel gear (86) and place them on the shaft (156). Mesh the gear (86) with the gears (91) and (117). Tighten the 4-40 by  $\frac{3}{16}$ -inch Bristo head screw (87) and 4-40 square nut (88).
  - (28) Place the gear clamp (85) on the brass gear (82). Place this assembly on the shaft (156). Tighten the 4-40 by  $\frac{3}{16}$ -inch Bristo head screw (83) and 4-40 square nut (84).
  - (29) Place the large brass gear assembly (81) on the shaft (176) and fasten it with the  $\frac{1}{4}$ -inch retaining ring (80).

*Note.* At this point loosen the gear clamp (85) to make the brass gear (82) mesh perfectly with the rear gear on the gear assembly (81). Tighten the gear clamp when the adjustment is completed.

- (30) Assemble the steel gear and shaft (79) by adding the separator (78), the steel gear (77), the  $\frac{3}{16}$ -inch retaining ring (76), and the  $\frac{3}{16}$ -inch steel washer (75). Install this assembly on the rear plate (146) as shown in figure 88.1.
- (31) Replace the pinned split gear assembly (73) and the  $\frac{3}{16}$ -inch washer (74) as shown in figure 87.1 while loading the split gear (122) two teeth.

*Note.* Loosen the gear clamp (121) on the split gear (122) to insure perfect mesh with the small gear on the gear assembly (73).

- (32) Reassemble the differential gear assembly (61) through (72) as follows:

- (a) Be sure that the loading springs (71) are in place.
  - (b) Replace the .395-inch retaining ring (70).
  - (c) Assemble the three small gear assemblies by installing the loading springs (68) on the pinned gear assembly (69); add the flat brass gears (67) and the .395-inch retaining rings (66).
  - (d) The three similar gear assemblies (65) must be placed on the pinned gear and detent assembly (72) while loading the split gear on this assembly by two teeth.
  - (e) Replace the three .122-inch retaining rings (64).
  - (f) Place the gear (63) so that the inner small gear meshes with the outer gear on split gear assemblies (65). Load the bottom half of the split gear assemblies (65) three teeth and gently rock the gear assembly (63) back and forth until all gears mesh.
- Note.* Be extremely careful when loading this assembly to insure proper operation.
- (g) Replace the three 4-40 by  $\frac{1}{4}$ -inch Phillips head screws (61) and the three No. 4 lockwashers (62). Partially tighten each screw and check the assembly to insure proper fit before final tightening.
  - (h) Before replacing the differential gear assembly, load the split gear (113) two teeth and hold it with a screw driver blade; drop the differential gear in place and remove the screw driver.
- (33) Replace the detent spring (60) and secure it with the two 6-32 by  $\frac{1}{4}$ -inch Phillips head screws (58) and the two No. 6 lockwashers (59).
  - (34) Replace the  $\frac{5}{16}$ -inch washer (57) on the front plate (45). Place the pinned split gear assembly (56) over the washer and fasten it with the  $\frac{1}{8}$ -inch retaining ring (55).
  - (35) Replace the triangular steel plate (54) on the front plate (45) with the three

- 6-32 by  $\frac{1}{4}$ -inch Phillips head screws (52) and the three No. 6 lockwashers (53).
- (36) Replace the large brass gear (51) and secure it with the  $\frac{1}{8}$ -inch retaining ring (50).
- (37) Replace the pinned gear and shaft (49) on the front panel (45) and secure it with the .225-inch retaining ring (48).
- (38) Replace the front plate (45) while loading two teeth on the split gears (56) and (102). Replace the three 8-32 by  $\frac{5}{16}$ -inch Phillips head screws (46) and three No. 8 lockwashers (47). Loosen the gear clamp (100) on the split gear (102) and adjust the gear (102) for perfect mesh on the rear gear of the gear assembly (56). Tighten the gear clamp (100).
- (39) Replace the 6-40 by  $\frac{5}{16}$ -inch machine screw (44).
- (40) Replace the gear and shaft assembly (42). When the gear and shaft assembly (42) is part way through the front plate (45) replace the  $\frac{3}{16}$ -inch washer (43) and the gear (41). Replace the hollow pin (40) to secure the gear (41). Push the assembly firmly in place and secure it with the .207-inch retaining ring (39).
- (41) Replace the gear (38) and secure it with the  $\frac{3}{32}$ -inch retaining ring (37). Be sure that the proper side is up for perfect mesh with the gear (42).
- (42) Replace the synchronization gear (36) with its green face up. Fasten it with the 6-32 by  $\frac{3}{16}$ -inch Phillips head screw (34) and No. 6 lockwasher (35).
- (43) Replace the two combination bevel and spur gears (32) and (33).
- (44) Replace the bevel gear (29) and the gear clamp (30) on the mechanical counter (25).
- (45) Replace the bevel gear (26) and the gear clamp (27) on the mechanical counter (25). Leave the gear clamps (27) and (30) loose until the mechanical counter is mounted.
- (46) Mount the mechanical counter (25) with the four 4-40 by  $\frac{5}{16}$ -inch Phillips head screws (23) and four No. 4 split lockwashers (24); tighten the 3-56 by  $\frac{1}{4}$ -inch Bristo head screws (28) and (31) on the gear clamps (27) and (30). Be sure that the bevel gears (26) and (29) mesh perfectly with the bevel gears (32) and (33) respectively.
- (47) Reassemble the clutch gear assembly as follows:
- Place the bushing (21) in the brass gear (12).
  - Place the four clutch plates (11) in the gear (12) as shown in figure 87.1.  
*Note.* Follow the illustration precisely.
  - Replace the steel plate (10).
  - Replace the two  $\frac{7}{16}$ -inch washers (9).
  - Replace the four  $1\frac{7}{32}$ -inch spring friction washers (8).
  - Replace the  $\frac{7}{16}$ -inch washer (7).
  - Replace the pressed split gear assembly (6).
  - Press this whole assembly together and replace the .395-inch retaining ring (5).
  - Slip the assembly over the shaft (22) and secure it with the .225-inch retaining ring (20).
  - Replace the  $\frac{1}{4}$ -inch washer (19) and the flat pin (18).
  - Replace the spring (17), spring holder (16), and the stop washer (15). Secure in place with the .225-inch retaining ring (14).
  - Replace the zero adjust shaft (13).
  - Place the lockwasher (2) and the  $\frac{5}{16}$ -24 hexagonal nut (1) on the shaft (22).
  - Mount the clutch gear assembly on the RF gear train assembly while loading two teeth on the split gear (6) to mesh with the spur gear part of the bevel gear assembly (33). Tighten the  $\frac{5}{16}$ -24 hexagonal nut (1) and replace the 6-32 by  $\frac{5}{16}$ -inch Phillips head screw (3) and No. 6 lockwasher (4).

(48) Replace the 8 slug racks and the 16 tension springs.

(49) Synchronize the Geneva system and overtravel coupler as follows:

(a) Rotate the rear portion of the gear (63) to the extreme clockwise position.

(b) Loosen the gear clamp (85).

(c) Keep rotating the rear portion of the gear (63) past the extreme clockwise position to a point midway between detent positions.

*Note.* The position should be checked visually on the detent assembly (72).

(d) Tighten the rear clamp (85).

(e) Rotate the rear portion of the gear (63) counterclockwise to the first detent position.

(f) Loosen the gear clamps (27) and (30) and adjust the mechanical counter to read 00 000 and tighten the gear clamps.

(50) With the mechanical counter reading 00 000, set the RF bandswitch (S201 through S210) to the position shown in figure 108 (part 1). Use S206 (fig. 64) as viewed from the rear for RF bandswitch setting. This is accomplished by loosening the gear clamp (150) and turning the shaft (151) with a pair of long-nose pliers. Tighten the gear clamp when the adjustment is completed.

(a) The RF bandswitch section S206 should be on contact 7 as shown in figure 108 (part 1). Rotate the rear portion of the gear (63) in a counterclockwise direction to read 01 000 on the frequency indicator. RF bandswitch section S206 should be on contact 6. Move the rear portion of the gear (63) counterclockwise to read 02 000 on the frequency indicator. RF bandswitch section S206 should be on contact 5. Following this same procedure for the remainder of the positions on the frequency indicator, S206 should be on contact 5 for 03 000, the other arm of the switch will be on contact 3 for 04 000, 05 000, 06 000, 07 000;

contact 2 for 08 000, 09 000, 10 000, 11 000, 12 000, 13 000, 14 000, and 15 000; and finally come to rest on contact 1 for 16 000 through 31 000.

(b) If the RF bandswitch does not track as shown in (a) above, repeat the procedure in (49) above and try a new setting before or beyond the midway point between the two detent positions.

(51) Rotate the rear gear of the gear assembly (63) in a counterclockwise direction till the mechanical counter reads 02 000.

(52) Synchronize the RF gear train according to the instructions in paragraphs 110a and b. Since the RF subchassis is removed from the receiver, move the rear gear of gear assembly (63) in a counterclockwise direction when it is desired to go to a higher channel.

(53) Replace the RF subchassis (par. 105d).

(54) Replace the front panel (par. 105b).

(55) Synchronize crystal oscillator bandswitch and VFO tuning shaft (par. 110c and d).

(56) Aline and adjust the receiver if necessary (pars. 111-120).

### 105.3. RF Gear Train Assembly Parts Legend (Added)

Index No.	Reference symbol	Description
1		$\frac{3}{16}$ -24 hex nut.
2		$\frac{5}{16}$ -inch lockwasher.
3		6-32 by $\frac{5}{16}$ -inch Phillips head screw.
4		No. 6 lockwasher.
5	H252	.395-inch inside diameter x .025 thick retaining ring.
6	O339	Steel split gear assembly, $2\frac{1}{4}$ -inch diameter, 108 teeth.
7		$\frac{7}{16}$ -inch flat washer.
8		$1\frac{7}{32}$ -inch spring friction washer.
9		$\frac{7}{16}$ -inch flat washer.
10		Steel plate, part of clutch assembly.
11		Clutch plates.
12	O338	Brass gear, $2\frac{1}{2}$ -inch diameter, 72 teeth.
13		Zero adjust shaft.
14	H516	Retaining ring, .225-inch diameter.
15		Stop washer.
16		Spring holder.

Index No.	Reference symbol	Description	Index No.	Reference symbol	Description
17		Stop spring for zero adjust knob.	59		No. 6 lockwasher.
18		Flat pin.	60		Detent spring.
19		1/4-inch washer.	61		4-40 by 1/4-inch Phillips head screw.
20	H516	.225-inch retaining ring.	62		No. 4 lockwasher.
21		Steel bushing.	63		Three gears, consisting of front steel gear, 3 1/4-inch diameter, 102 teeth; rear brass gear, 3 1/8-inch diameter, 100 teeth; small steel gear, 5/8-inch diameter, 28 teeth.
22		Clutch assembly shaft.	64	H716	.122-inch retaining ring.
23		4-40 by 5/16-inch Phillips head screw.	65		Brass split gear assembly with small steel gear, 1 1/4-inch diameter. the split gears have 56 teeth each and the small gear has 21 teeth.
24		No. 4 split lockwashers.	66	H232	.395-inch retaining ring.
25		Mechanical counter.	67	O279	Brass gear, 1 3/16-inch diameter, 56 teeth.
26	O334	Beveled gear, 3/4-inch diameter, 48 teeth.	68		Steel loading spring.
27		Gear clamp.	69	O279	Pinned brass and steel gear assembly, brass gear 1 3/16-inch diameter, 56 teeth, steel gear, 1/2-inch diameter, 21 teeth.
28		3-56 by 1/4-inch Bristo head screw.	70	H252	.395-inch retaining ring.
29	O335	Brass bevel gear, 7/16-inch diameter, 24 teeth.	71		Loading spring.
30		Gear clamp.	72	O282	Split gear and detent assembly, small brass split gear 1 3/8-inch diameter, 63 teeth, brass or steel detent 2 3/8-inch diameter with large steel rear gear, 2 1/8-inch diameter, 65 teeth.
31		3-56 by 1/4-inch Bristo head screw.	73	O296	Large brass split gear assembly, 2 3/4-inch diameter, 85 teeth with small steel gear, 25 teeth.
32	O341	Gear assembly, front gear beveled, 24 teeth, rear 50 teeth.	74		3/16-inch washer.
33	O333	Gear assembly, front gear beveled, 48 teeth, rear 27 teeth.	75		3/16-inch steel washer.
34		6-32 by 3/16-inch Phillips head screw.	76		3/16-inch retaining ring.
35		No. 6 lockwasher.	77		Steel gear, 2 1/16-inch diameter, 80 teeth.
36	O330	Green-faced gear, 1 1/2-inch diameter, 70 teeth.	78		Aluminum separator, 2-inch diameter, 3/32-inch thick.
37	H222	.207-inch retaining ring.	79		Steel gear, 2 1/16-inch diameter, 80 teeth, 1 1/4-inch long shaft.
38	O322	Brass gear, 1-inch diameter, 64 teeth.	80	H234	.281-inch retaining ring.
39	H222	.207-inch retaining ring.	81	O268	Brass gear assembly, 3 1/8-inch diameter, 100 teeth, smaller gear 2 3/8-inch diameter, 75 teeth.
40		Hollow pin.	82	O300	Large brass gear, 2 1/16-inch diameter, 80 teeth.
41		Brass gear, 1 5/16-inch diameter, 32 teeth.	83		4-40 by 1/16-inch Bristo head screw.
42		Brass gear and shaft assembly (gear 1/2-inch diameter, 32 teeth).	84		4-40 square nut.
43		3/16-inch washer.	85		Gear clamp.
44		6-40 by 5/16-inch machine screw.	86	O229	Small steel gear, 1 5/16-inch diameter, 32 teeth.
45		RF gear train front plate assembly.	87		4-40 by 1/16-inch Bristo head screw.
46		8-32 by 5/16-inch Phillips head screw.	88		4-40 square nut.
47		No. 6 lockwasher.	89		Gear clamp.
48	H516	.225-inch retaining ring.	90	H716	.122-inch retaining ring.
49	O301	Steel gear, 1/16-inch diameter on 1 1/4-inch long shaft, 17 teeth.			
50	H716	.122-inch retaining ring.			
51	O323	Brass gear, 3 1/8-inch diameter, 100 teeth.			
52		6-32 by 1/4-inch Phillips head screw.			
53		No. 6 lockwasher.			
54		Triangular steel plate with bushing.			
55	H716	.122-inch retaining ring.			
56	O324	Steel split gear assembly 68 teeth, with pinned brass gear, 40 teeth.			
57	O325	3/16-inch steel washer.			
58		6-32 by 1/4-inch Phillips head screw.			

Index No.	Reference symbol	Description	Index No.	Reference symbol	Description
91	O266	Brass gear, 1½-inch diameter, 53 teeth.	135		Steel shaft.
92		4-40 by ¼-inch Bristo head screw.	136		6-32 hexagonal nut.
93		4-40 square nut.	137		No. 6 lockwasher.
94		Gear clamp.	138		⅜-inch retaining ring.
95	O273	Steel gear, 1⅜-inch diameter, 54 teeth.	139	O309	Small steel gear combination 8 teeth and 4 teeth, ⅞-inch diameter.
96		Steel split gears, 2⅝-inch diameter, 108 teeth.	140		Steel shaft, 6-32 thread on one end.
97		4-40 by ¼-inch Phillips head screw.	141		6-32 by ⅝-inch hexagonal head screw.
98		4-40 by ⅜-inch Bristo head screw.	142		No. 6 lockwasher.
99		4-40 square nut.	143	H716	.122-inch retaining ring.
100		Gear clamp.	144	O307	Brass gear, 1⅝-inch diameter, 21 teeth.
101	O261	Small steel gear, 1⅜-inch diameter, 54 teeth.	145		Steel shaft.
102	O277	Large steel split gear, 2⅝-inch diameter, 72 teeth.	146		Gear train assembly rear plate.
103	O278	4-40 by ⅜-inch Bristo head screw.	147	H731	.225-inch retaining ring.
104		4-40 square nut.	148		4-40 by ⅝-inch Bristo head screw.
105		Gear clamp.	149		4-40 square nut.
106	O262	Steel split gear, 2⅝-inch diameter, 108 teeth.	150		Gear clamp.
107	O263	4-40 by ⅜-inch Bristo head screw.	151		RF band switch shaft.
108		4-40 square nut.	152	O303	1⅞-inch diameter steel gear, 24 teeth.
109		Gear clamp.	153		6-32 by ⅜-inch Phillips head screw.
110		Steel split gear, 1⅞-inch diameter, 54 teeth.	154		No. 6 lockwasher.
111	O261	Small steel gear, 1⅜-inch diameter, 54 teeth.	155		Flange for crystal switch shaft.
112		4-40 by ¼-inch Phillips head screw.	156		Steel gear and shaft assembly, ⅝-inch diameter, 16 teeth.
113	O289	Steel split gear assembly, 2⅝-inch diameter, 108 teeth.	157		Hollow pin.
114		No. 6/0 taper pin.	158		Oldham coupler.
115		1st variable IF cam, rear.	159		⅜-inch steel washer.
116		Cam shaft.	160		No. 6/0 taper pin.
117	O267	Brass gear, fixed to first variable IF cam, front, 2⅝-inch diameter, 90 teeth.	161		2d variable IF cam, front.
118		No. 6/0 taper pin.	162		No. 6/0 taper pin.
119		4-40 by ⅜-inch Bristo head screw.	163		2d variable IF cam, inside.
120		4-40 square nut.	164		No. 6/0 taper pin.
121		Gear clamp.	165		2d variable IF cam, inside.
122	O275	Steel split gear, 2⅝-inch diameter, 72 teeth.	166		Cam shaft.
123	O276	4-40 by ⅜-inch Bristo head screw.	167		No. 6/0 taper pin.
124		4-40 square nut.	168		2d variable IF cam, rear.
125		Gear clamp.	169		No. 6/0 taper pin.
126	O264	Steel split gear, 2⅝-inch diameter, 108 teeth.	170		16 to 32 mc RF cam, front.
127	O265	8-32 by ⅝-inch Phillips head screw.	171		Cam shaft.
128		No. 8 lockwasher.	172		No. 6/0 taper pin.
129		Steel plate.	173		16 to 32 mc RF cam, rear.
130		⅜-inch steel ball.	174		No. 6/0 taper pin.
131	O312	Lost motion gear, 10 teeth.	175	O359	Steel gear and brass cam assembly, 8 to 16 mc, front; gear is 1¼-inch diameter, 54 teeth.
132	H716	.122-inch retaining ring.	176		Cam shaft.
133		⅜-inch washer.	177		No. 6/0 taper pin.
134	O313	Brass gear, 1⅝-inch diameter, 90 teeth.	178		8 to 16 mc RF cam, rear.
			179		No. 6/0 taper pin.
			180		4 to 8 mc RF cam, front.
			181		Cam shaft.
			182		No. 6/0 taper pin.
			183		4 to 8 mc RF cam, rear.

Index No.	Reference symbol	Description
184		No. 6/0 taper pin.
185		2 to 4 mc RF cam, front.
186		Cam shaft.
187		No. 6/0 taper pin.
188		2 to 4 mc RF cam, rear.
189		No. 6/0 taper pin.
190		.5 to 1 mc RF cam, front.
191		Cam shaft.
192		No. 6/0 taper pin.
193		.5 to 1 mc RF cam, rear.
194		No. 6/0 taper pin.
195		1 to 2 mc RF cam, front.
196		Cam shaft.
197		No. 6/0 taper pin.
198		1 to 2 mc RF cam, rear.
199		8-32 by $\frac{3}{32}$ -inch Bristo head set-screw.
200		$\frac{1}{4}$ -inch coupler.
201		$\frac{1}{4}$ -inch fiber shaft.
202		$\frac{3}{8}$ -32 hexagonal head nut.
203		$\frac{3}{8}$ -inch lockwasher.
204		$\frac{3}{8}$ -inch flat washer.
205		$\frac{3}{8}$ -inch insulated washer.
206		6-32 by $\frac{3}{8}$ -inch Phillips head screw.
207		No. 6 lockwasher.
208		1 brackets.
209		Bracing rods.
210		8-32 by $\frac{3}{8}$ -inch hexagonal head screw.
211		No. 8 lockwasher.
212		8-32 by $\frac{1}{4}$ -inch flathead Phillips head screw.
213		Separator rod, $1\frac{1}{2}$ -inch long by $\frac{5}{16}$ -inch wide.
214		8-32 by $\frac{3}{8}$ -inch hexagonal head screw.
215		No. 8 lockwasher.
216		8-32 by $\frac{1}{4}$ -inch flathead Phillips head screw.
217		No. 8 lockwasher.
218		RF subchassis rear plate.

Page 113.

Page 115, paragraph 108g. Add subparagraph *h* after *g*.

*h. Adapter.* A 50-ohm Test Adapter MX-1487/URM-25D as supplied with RF Signal Generator Set AN/URM-25D.

Paragraph 110a, note, line 5. Delete "to avoid losing nut."

Page 116, paragraph 110a(1):

Line 12. Change "high" to: low

Line 14. Change "999" to: 000

Page 117, paragraph 110. Make the following changes:

Subparagraph *b*(4), line 3. Change "more than 50 ohms" to: 1 megohm.

Subparagraph *b*(5). At the end of the second sentence, add: of less than 50 ohms.

Subparagraph *b*(5), line 7. Change "crystal-oscillator" to: RF.

Subparagraph *b*(6). Delete (6) and substitute:

(6) Rotate the MEGACYCLE CHANGE control fully counterclockwise beyond the first detent position; then rotate it clockwise to the first detent position.

Subparagraph *b*(8), line 5. Change "3" to: 7.

Page 119, paragraph 111:

Subparagraph *n*, line 4. Change ".1" to: 1.

Subparagraph *n*, line 7. Change ".1" to: 1.

Page 123.

### 117.1. Measuring Overall Gain (Added)

#### *a. Receiver Adjustment.*

(1) Connect the receiver under test to an ac power line and permit the receiver to warm up to operating temperature.

(2) Set the receiver front panel controls as follows:

- (a) BANDWIDTH to 8 KC.
- (b) FUNCTION to MGC.
- (c) RF GAIN to 10 (max).
- (d) BFO to OFF.

#### *b. Connection of Vacuum Tube Voltmeter.*

(1) Connect a vtvm such as Electronic Multimeter TS-505/U, or equivalent, between DIODE LOAD terminal 14, on the rear terminal strip of the receiver and ground (fig. 22). Do not disturb the jumper between terminals 14 and 15.

(2) Set the FUNCTION switch of the meter for measuring —dc volts.

(3) Set the RANGE switch to 10 volts.

*c. Connection of Signal Generator.* Connect a signal generator such as Signal Generator Set AN/URM-25 through a suitable dummy an-

tenna (par. 116c), and an Adapter Connector UG-971/U and Adapter Connector UG-636/U, to the BALANCED 125 OHM ANTENNA jack J108 located on the back panel of the receiver (fig. 22).

- (1) Connect the signal generator power cord to an ac power source.
- (2) Turn the power switch to ON and permit the signal generator to reach operating temperature.
- (3) Turn the internal modulation control to OFF.
- (4) Tune the signal generator and the radio receiver both to 6 megacycles.
- (5) Adjust the signal generator output attenuator until the vtvm reads  $-7.0$  volts. The receiver gain is normal when the signal generator output meter indicates between 1 and 4 microvolts. If more than 4 microvolts is required, follow the procedure in *d* below.

*d.* If the overall gain is below normal, test the tubes in the RF amplifier. Replace the burned out, shorted, or weak tubes, until the receiver overall gain reaches a normal value. If after testing and replacing all weak tubes in the RF amplifier, the overall gain is still below normal, check the adjustment of the GAIN ADJ potentiometer R562 (par. 118).

Page 123.

### 118. Adjustment of GAIN ADJ Potentiometer R562 (Superseded)

*a.* If a generator output of more than 4 microvolts is required to produce a reading of  $-7.0$  volts when measuring the overall gain (par. 117.1), the receiver gain is below normal. The following procedure should be followed to restore the receiver overall gain to normal.

- (1) Disconnect connectors P225 and P226 from jacks J525 and J526, located on the IF subchassis (fig. 68).
- (2) Connect a suitable terminated signal generator lead between IF jack J525 and receiver ground (chassis). When using RF Signal Generator Set AN/URM-25, it must be terminated in Test Adapter MX-1487/URM-25D, or equivalent.

- (3) Connect a vtvm, such as Electronic Multimeter TS-505/U, between DIODE LOAD terminal 14, on the rear terminal strip of the receiver and ground (fig. 22). Do not disturb the jumper between terminals 14 and 15. Set the FUNCTION switch of the meter for measuring  $-dc$  volts.

- (4) Connect the receiver under test to an ac source and allow it to warm up to operating temperature. Set the receiver controls as follows:

- (a) BANDWIDTH to 8 KC.
- (b) FUNCTION to MGC.
- (c) RF GAIN to 10 (maximum).
- (d) BFO to OFF.

- (5) Turn the modulation control to OFF.

- (6) Tune the signal generator to 455 KC. A hum in the audio output, when the unmodulated 455 KC signal is injected into the IF amplifier, may indicate a faulty type 6BJ6 tube in third, fourth, or fifth IF amplifier stages (V503, V504, or V505). This can be checked by substituting another tube of the same type, because these defects often are not detected in a standard tube tester.

- (7) Adjust the signal generator for an output of 150 microvolts.

*Note.* In rare instances, it may not be possible to produce  $-7.0$ -volts at the diode load terminal with an input to IF subchassis jack J525 of 150 microvolts. In this case, the IF gain should be set so that the input to the IF is not less than 100 microvolts or greater than 200 microvolts to produce the  $-7.0$ -volts at diode load terminal 14.

- (8) Adjust the GAIN ADJ potentiometer R562 (fig. 68) for a reading of  $-7.0$ -volts on the vtvm.

*b.* If the  $-7.0$ -volt reading cannot be obtained after the maximum adjustment of GAIN ADJ potentiometer R562, remove and test the IF amplifier tubes in a mutual conductance tube tester such as Electron Tube Test Set TV-7, or equivalent. Replace burned out and shorted tubes. Record the mutual conductance of all the tubes tested. Replace them in their original sockets, and readjust the GAIN ADJ potentiometer R562 until the vtvm indicates  $-7.0$  volts.

If the —7.0-volt reading cannot be obtained after replacing burned out and/or shorted tubes with good tubes, replace the weakest tubes in the IF amplifier, one at a time, and again readjust GAIN ADJ potentiometer R562, after each tube replacement, until a reading of —7.0 volts is obtained.

c. Remove the signal generator from jack J525, and reconnect plugs P225 and P226 to jacks J525 and J526. Disconnect the vtm.

d. Check the overall gain of the receiver in accordance with paragraph 117.1.

e. If the overall gain is still below normal, check the receiver alinement in accordance with the instructions in paragraphs 111 through 116.

Figure 98. Add the following to the notes:

3. IN RECEIVERS MODIFIED BY MWO 11-5820-294-35/1 THE B+ 3/8A FUSE F102 IS NOT CONNECTED BETWEEN P120-5 AND +300V UNREGULATED.

Figure 105. Add the following to the notes:

5. IN POWER SUPPLIES MODIFIED BY MWO 11-5820-294-35/1 THERE IS NO CONNECTION BETWEEN TERMINALS 10 AND 6

[AG 413.44 (3 Dec. 58)]

BY ORDER OF THE SECRETARIES OF THE ARMY AND THE AIR FORCE:

OFFICIAL:

R. V. LEE,  
Major General, United States Army,  
The Adjutant General.

OFFICIAL:

J. L. TARR,  
Colonel, United States Air Force,  
Director of Administrative Services.

OF T801; THERE IS A WIRE CONNECTED BETWEEN TERMINAL 6 OF T801 AND TERMINAL 15 OF J818.

Figure 106. Make the following changes:

Station 32. Delete wire 2-35.

Station 35. Label the upper and lower terminals of fuse F102 1 and 2 respectively.

Station 41. Change wire 42-1 to 42-2.  
Change wire 35-1 to 42-1.

Add the following to the notes:

5. ON RECEIVER MAIN FRAMES MODIFIED BY MWO 11-5820-294-35/1, STATION 35 WIRE 1-33 IS 7-40, WIRE 5-41 IS 15-41 AND B+ IS HV. AT STATION 37 THERE IS NO WIRE 15-41. AT STATION 41 THERE IS A WIRE ADDED BETWEEN THE CABLE AND TERMINAL 1 OF C101 LABELED 5-41, CHANGE WIRE 35-1 TO 42-2, AND WIRE 37-2 TO 35-1. AT STATION 40, ADD A WIRE BETWEEN TERMINAL 7 AND THE CABLE LABELED 35-2.

Figure 107 (Part 2): Complete the broken line from the grid (pin 1) of V501 to S501.

MAXWELL D. TAYLOR,  
General, United States Army,  
Chief of Staff.

THOMAS D. WHITE,  
Chief of Staff, United States Air Force.



DISTRIBUTION:

*Active Army:*

ASA (2)  
CNGB (1)  
Technical Stf, DA (1) except  
    CSigO (30)  
Technical Stf Bd (1)  
USCONARC (5)  
USA Arty Bd (1)  
USA Armor Bd (1)  
USA Inf Bd (1)  
USA Air Def Bd (1)  
USA Abn & Elct Bd (1)  
USA Avn Bd (1)  
USA Armor Bd Test Sec (1)  
USA Air Def Bd Test Sec (1)  
USA Arctic Test Bd (1)  
US ARADCOM (2)  
US ARADCOM Rgn (2)  
OS Maj Comd (5)  
Log Comd (5)  
MDW (1)  
Armies (5)  
Corps (2)  
Div (2)  
USATC (2)  
Svc Colleges (5)  
Br Svc Sch (5) except  
    USASCS (25)  
Gen Depots (2) except  
    Atlanta Gen Depot (None)  
Sig Sec, Gen Depots (10)  
Sig Depots (17)  
Army Pictorial Cen (2)  
Engr Maint Cen (1)  
USA Ord Msl Comd (3)  
TASSA (15)  
Mid-Western Rgn Ofc (TASSA) (1)  
USA Sig Pub Agcy (8)  
USA Sig Engr Agcy (1)

USA Comm Agcy (2)  
USA Sig Eqp Spt Agcy (2)  
USA Sig Msl Spt Agcy (13)  
WRAMC (1)  
AFIP (1)  
AMS (1)  
Ports of Emb (OS) (2)  
Trans Terminal Comd (2)  
Army Terminals (2)  
OS Sup Agcy (2)  
Yuma Test Sta (2)  
USA Elct PG (1)  
Sig Lab (5)  
Sig Fld Maint Shops (3)  
Fld Comd, AFSWP (5)  
Mil Dist (1)  
Sector Comd, USA Corps (Res) (1)  
USA Corps (Res) (1)  
Mil Mis (Nicaragua) (5)  
JBUSMC (2)  
Mil Mis (Boliva) (5)  
Units org under fol TOE:  
    11-7 (2)  
    11-16 (2)  
    11-32 (2)  
    11-57 (2)  
    11-85 (2)  
    11-86 (2)  
    11-500 (AA-AE) (2)  
    11-557 (2)  
    11-587 (2)  
    11-592 (2)  
    11-597 (2)  
    32-51 (2)  
    32-55 (2)  
    32-56 (2)  
    32-57 (2)

NG: State AG (3); units—same as Active Army except allowance is one copy to each unit.

USAR: None.

For explanation of abbreviations used, see AR 320-50.

TECHNICAL MANUAL  
 No. 11-856  
 TECHNICAL ORDER  
 No. 31R1-2URR-154

DEPARTMENTS OF THE ARMY AND  
 THE AIR FORCE

WASHINGTON 25, D. C., 11 January 1955

**RADIO RECEIVER R-390/URR**

	<i>Paragraphs</i>	<i>Page</i>
CHAPTER 1. INTRODUCTION		
Section I. General .....	1, 2	3
II. Description and data .....	3-13	3
CHAPTER 2. OPERATION		
Section I. Service upon receipt of Radio Receiver R-390/URR .....	14-19	16
II. Controls and instruments .....	20, 21	22
III. Operation under usual conditons .....	22-28	25
IV. Operation under unusual conditions .....	29-32	28
CHAPTER 3. ORGANIZATIONAL MAINTENANCE		
Section I. Organizational tools and equipment .....	33, 34	29
II. Preventive maintenance services .....	35-38	29
III. Lubrication and weatherproofing .....	39, 40	33
IV. Troubleshooting at organizational maintenance level .....	41-47	33
CHAPTER 4. THEORY		
Section I. Theory of Radio Receiver R-390/URR .....	48, 49	41
II. Circuit analysis .....	50-79	43
III. Analysis of mechanical tuning system .....	80-82	78
CHAPTER 5. FIELD MAINTENANCE		
Section I. Troubleshooting at field maintenance level .....	83-104	82
II. Repairs .....	105-107	106
III. Alinement and adjustment procedures .....	108-120	114
IV. Final testing .....	121-127	125
CHAPTER 6. SHIPMENT AND LIMITED STORAGE AND DEMOLITION TO PREVENT ENEMY USE		
Section I. Shipment and limited storage .....	128, 129	129
II. Demolition of materiel to prevent enemy use .....	130, 131	129
INDEX .....		132

TM 11-856-1

DEPARTMENTS OF THE ARMY AND  
THE AIR FORCE

Washington 25, D. C., 11 January 1953

Technical Manual  
No. 11-856  
Technical Order  
No. 8181-2URR-104

RADIO RECEIVER R-390/URR

CHAPTER 1 INTRODUCTION  
Section 1 General

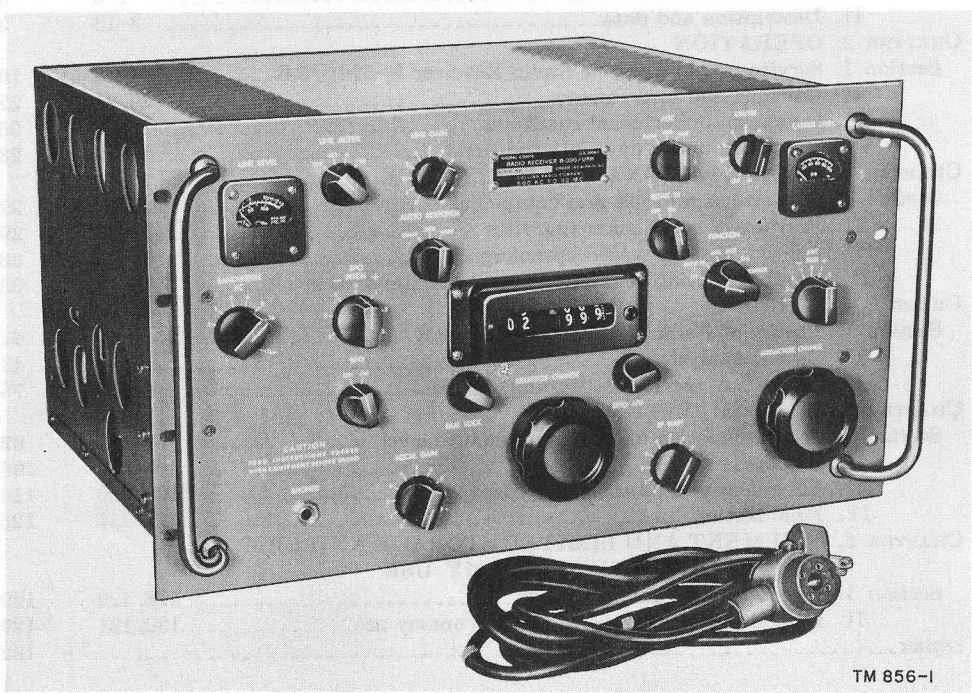

Figure 1. Radio Receiver R-390/URR.

# CHAPTER 1

## INTRODUCTION

### Section I. GENERAL

#### 1. Scope

This technical manual contains information for the guidance and instruction of all concerned. It contains instructions for the installation, operation, maintenance, and repair of Radio Receiver R-390/URR.

#### 2. Forms and Records

The following forms will be used for reporting unsatisfactory conditions of Army materiel and equipment:

*a.* DD Form 6, Report of Damaged or Improper Shipment, will be filled out and forwarded as prescribed in SR 745-45-5 (Army), Navy Shipping Guide, Article 1850-4 (Navy), and AFR 71-4 (Air Force).

*b.* DA Form 468, Unsatisfactory Equipment Report, will be filled out and forwarded to the

Office of the Chief Signal Officer, as prescribed in SR 700-45-5.

*c.* DD Form 535, Unsatisfactory Report, will be filled out and forwarded to Commanding General, Air Materiel Command, Wright-Patterson Air Force Base, Dayton, Ohio, as prescribed in SR 700-45-5 and AFR 65-26.

*d.* DA Form 11-238, Operator First Echelon Maintenance Check List for Signal Corps Equipment (Radio Communication, Direction Finding, Carrier, Radar), will be prepared in accordance with instructions on the back of the form.

*e.* DA Form 11-239, Second and Third Echelon Maintenance Check List for Signal Corps Equipment (Radio Communication, Direction Finding, Carrier, Radar), will be prepared in accordance with instructions on the back of the form.

*f.* Use other forms and records as authorized.

### Section II. DESCRIPTION AND DATA

#### 3. Purpose

Radio Receiver R-390/URR (fig. 1) is a high-performance, exceptionally stable, general-purpose receiver for use in both fixed and mobile service. The receiver provides reception of continuous wave (cw), modulated continuous wave (mcw), voice, and frequency-shift keyed signals within a frequency range of .5 to 32 megacycles (mc).

#### 4. System Application

*a. Space-Diversity Receiving System (fig. 2).*

- (1) Two or three Radio Receivers R-390/URR can be connected as shown in figure 2 as a space-diversity receiving system for reception of voice signals. This system provides uniform-strength output to a loudspeaker or headset, regardless of fading of signals. Diversity combining to obtain a uniform output is accomplished by using a common detector diode lead for the receivers.

- (2) Rhombic or doublet antennas spaced approximately 600 feet apart are connected to the balanced antenna jacks (J108) of the two receivers.
- (3) The detector diode load of receiver B is made to be common to both receivers by connecting terminals 14 of both receivers together and removing the jumper between terminals 14 and 15 of receiver A. The audio system of receiver B only is used. A loudspeaker is connected in the manner shown from terminal 6 to ground. A balanced line may be connected between terminals 10 and 13 to supply audio to some remote location.
- (4) In the presence of a strong signal on the antenna of receiver A, automatic gain control (agc) voltage produced in this set increases and, by means of the common connection between terminals 4 of both receivers, is applied to the controlled

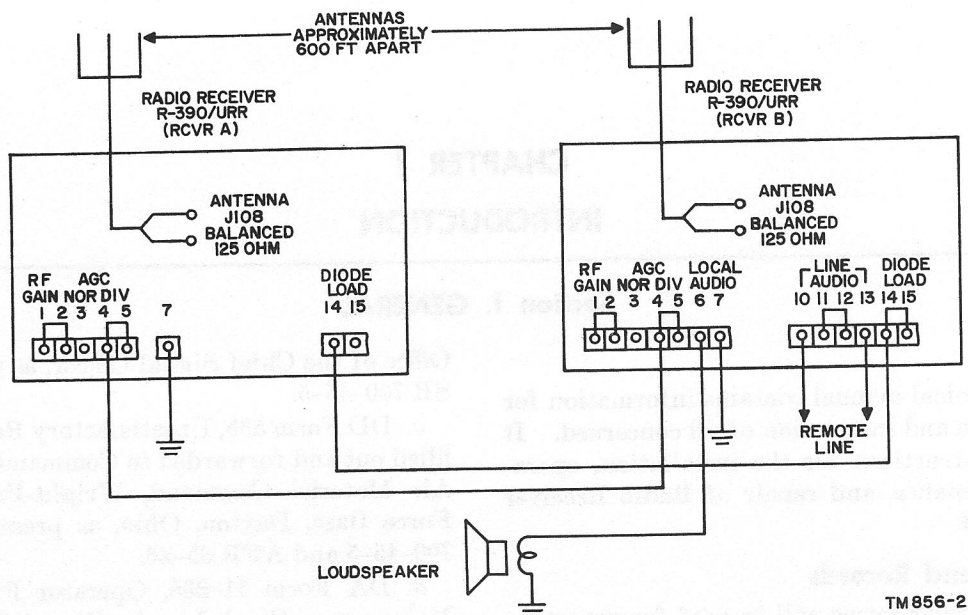

Figure 2. Space-diversity receiving system, block diagram.

stages of both receivers. Thus, the weak signal on the antenna of receiver B is further decreased by reducing the gain of the controlled stages of this receiver. The opposite would be true when the signal on the antenna of receiver B is stronger than that on the antenna of receiver A. A jumper for normal reception is removed from terminals 3 and 4 of both receivers and is placed between terminals 4 and 5. This connects a crystal diode into the circuits to prevent loading of the agc circuit of the controlling receiver by the agc circuit of the passive receiver.

*b. Space-Diversity Radioteletype Receiving System, Type 1* (fig. 3). Figure 3 shows two Radio Receivers R-390/URR connected in a space-diversity radioteletype receiving system. The doublet or rhombic antennas feed the incoming frequency-shift signals to the receivers, where they are converted to a frequency of 2,125 cycles for the MARK conditions and 2,975 cycles for the SPACE condition of the radioteletype terminal equipment sending contacts. The outputs taken from the LINE AUDIO outputs of the receivers are applied to Radioteletype Terminal Equipment AN/FGC-1( ), which provides diversity combining and produces direct current (dc) pulses for operation of teletypewriter equipment. The re-

ceivers are connected for normal operation as described in paragraph 17.

*c. Space-Diversity Radioteletype Receiving System, Type 2* (fig. 4). Two Radio Receivers R-390/URR also can be used in the type of space-diversity radioteletype receiving system shown in figure 4. The doublet or rhombic antennas feed the incoming frequency-shift signals to the receivers, where the carrier frequency is converted to a 455-kilocycle (kc) intermediate frequency (if.). This if. signal, taken from the 50 OHM IF OUTPUT circuit of the receivers, then is fed to Frequency Shift Converter CV-116/URR, which provides diversity combining and produces dc pulses for operation of teletypewriter equipment. The receivers are connected for normal operation as described in paragraph 17.

*d. Single-Sideband Radioteletype Receiving System.*

- (1) A Radio Receiver R-390/URR and a Single Sideband Converter CV-157/URR may be connected as shown in figure 5 for the reception of single-sideband signals occupying 12 kc of radio frequency (rf) spectrum space divided into two 6-kc sidebands on both sides of a reduced carrier, or to receive a double-sideband signal, either amplitude modulated or phase modulated, occupying up to a total of 12 kc of spectrum space. If

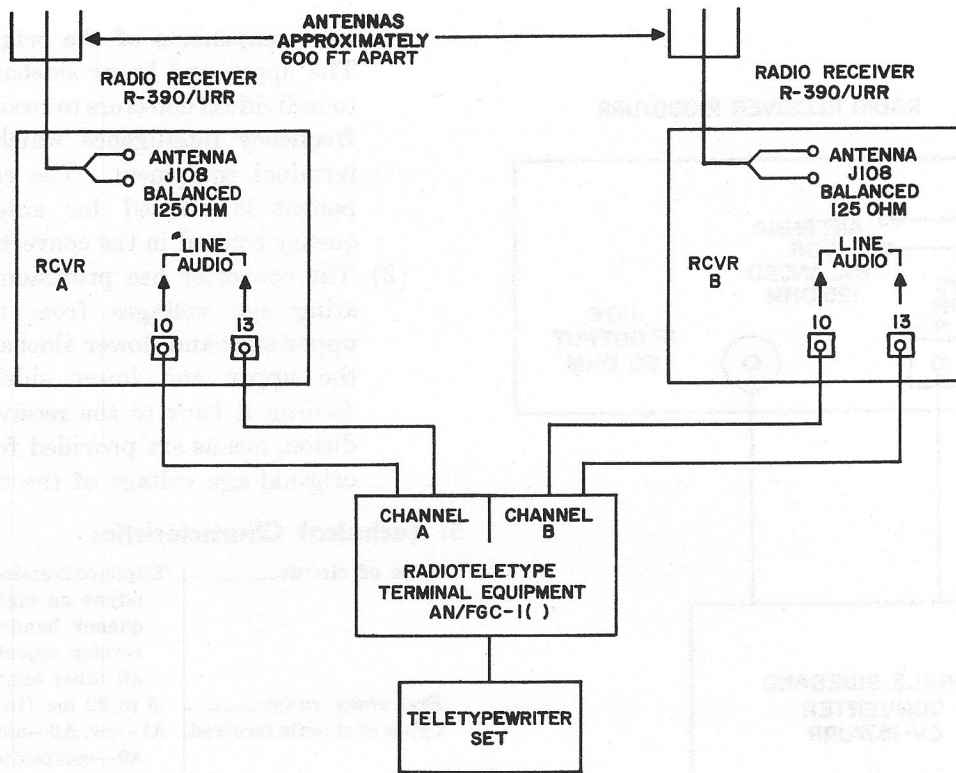

TM 856-3

Figure 3. Space-diversity radioteletype receiving system, type 1, block diagram.

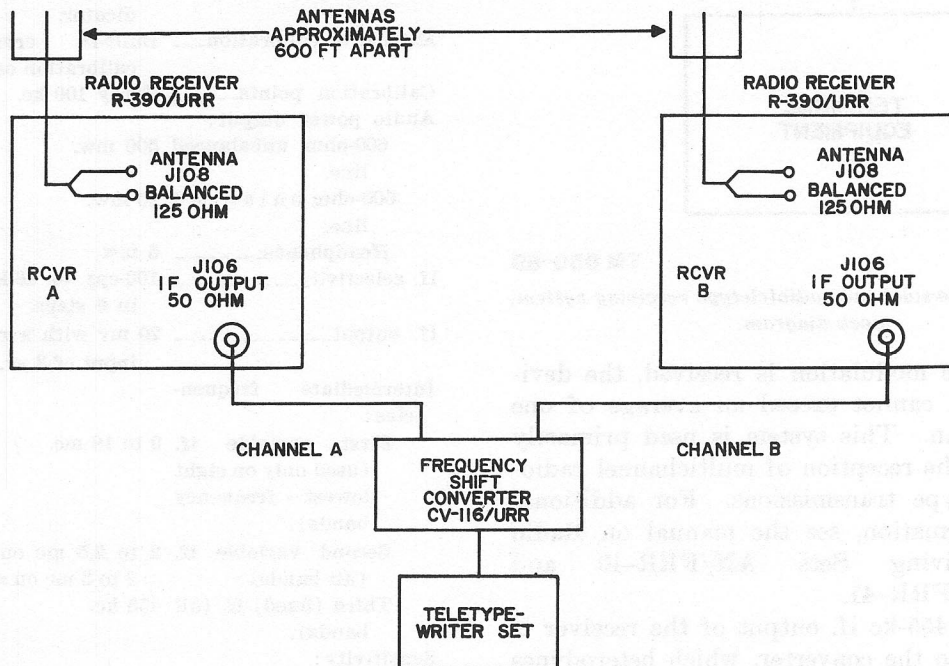

TM 856-4

Figure 4. Space diversity radioteletype receiving system, type 2, block diagram.

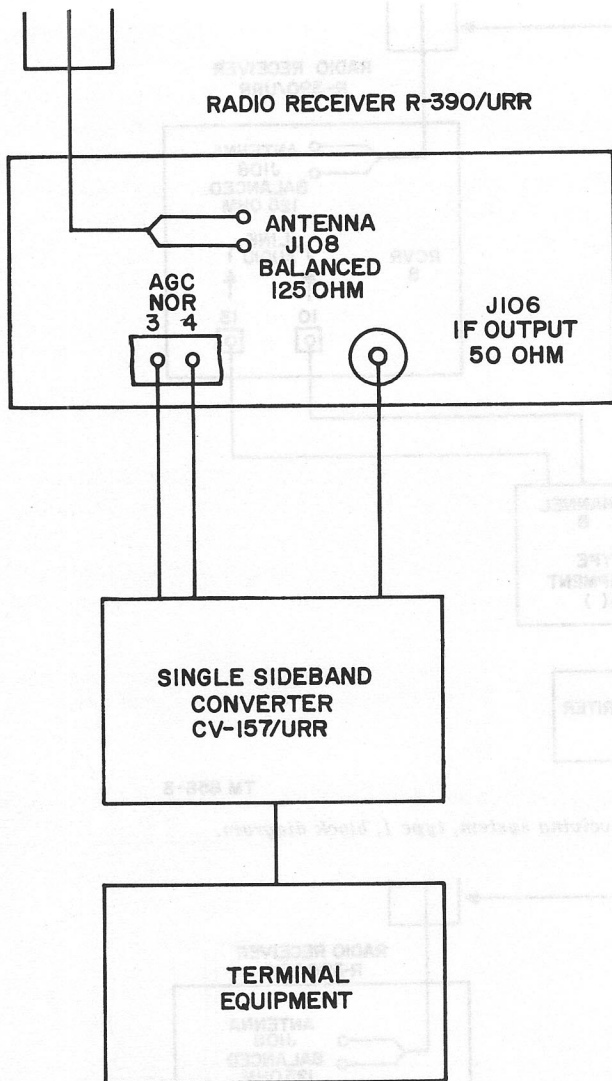

TM 856-89

Figure 5. Single-sideband radioteletype receiving system, block diagram.

phase modulation is received, the deviation cannot exceed an average of one radian. This system is used primarily for the reception of multichannel radioteletype transmissions. For additional information, see the manual on Radio Receiving Sets AN/FRR-40 and AN/FRR-41.

- (2) The 455-kc if. output of the receiver is fed to the converter, which heterodynes the if. signal to 100 kc. The 100-kc signal is amplified and fed through highly selective filter circuits to separate the upper sideband, lower sideband, and car-

rier components of the original signal. The upper and lower sidebands are fed to individual detectors to recover the low-frequency intelligence which is fed to terminal equipment. The carrier component is utilized for automatic frequency control in the converter.

- (3) The converter has provision for generating agc voltages from the carrier, upper sideband, lower sideband, or both the upper and lower sidebands, and feeding it back to the receiver. In addition, means are provided for using the original agc voltage of the receiver.

## 5. Technical Characteristics

Type of circuit.....	Triple-conversion superheterodyne on eight lowest frequency bands; double-conversion superheterodyne on all other bands.
Frequency range .....	.5 to 32 mc (in 32 steps).
Types of signals received..	A1—cw, A2—mcw, A3—voice, A9—composite transmissions, F1—frequency-shift keying.
Type of tuning.....	Continuous; frequency read directly on countertype indicator.
Method of calibration---	Built-in crystal-controlled calibration oscillator.
Calibration points.....	Every 100 kc.
Audio power output:	
600-ohm unbalanced line.	500 mw.
600-ohm balanced line.	10 mw.
Headphones.....	5 mw.
If. selectivity.....	100-cps to 16-kc bandwidth, in 6 steps.
If. output.....	20 mv with a receiver signal input of 3 $\mu$ v.
Intermediate frequencies:	
First variable if.	9 to 18 mc. (used only on eight lowest - frequency bands).
Second variable if.	2 to 2.5 mc on lowest step; 2 to 3 mc on all other steps.
Third (fixed) if.	(all bands). 455 kc.
Sensitivity:	
Am signals.....	3 $\mu$ v or better.
Cw signals.....	1 $\mu$ v or better.
Power source.....	115/230 volts ac $\pm$ 10%, 48-62 cps through Power Supply PP-621/URR.

Power input:  
 115/230 volts ac----- 270 watts total; 170 watts  
 with oven heaters off.

Number of tubes----- 33 (including ballast tube  
 RT512).

Antennas:  
 Unbalanced ----- Random length straight-wire  
 or vehicular-mounted whip.  
 Balanced ----- 125-ohm nominal terminating  
 impedance; matches 50- to  
 200-ohm balanced transmis-  
 sion lines or unbalanced  
 transmission lines using  
 adapters.

Temperature range----- -40° C. (-40° F.) to 55° C.  
 (131° F.).

Altitude ----- Up to 10,000 ft.

Weight ----- 80 lb (including Power Sup-  
 ply PP-621/URR).

## 6. Packaging Data (fig. 6)

When packed for export or domestic shipment, Radio Receiver R-390/URR is wrapped in paper and placed in an inner corrugated fiberboard car-

ton. Cleated wooden spacers are used to hold the receiver securely within the carton and to prevent damage to the controls and connections on the front and back panels. In the space between the back panel of the receiver and the rear wooden spacer are stored two technical manuals, eight 8-unit bags of silica gel, and a package containing Power Cable Assembly CX-1358/U. The inner corrugated fiberboard carton is inclosed in a sealed, moisture-vaporproof barrier, and is placed in an outer, tight-fitting corrugated cardboard carton. This outer carton is wrapped in moisture-resistant paper, sealed with tape, placed in a wooden crate containing excelsior, and secured with metal straps. The complete package is 21 inches high by 32 inches wide by 32 inches long, giving it a volume of approximately 12.4 cubic feet. The running spares for the receiver are shipped in a separate, paper-wrapped, corrugated fiberboard carton.

*Note.* Items may be packaged in a manner different from that shown, depending on the supply channel.

## 7. Table of Components

Component	Required No.	Height (in.)	Depth (in.)	Length (in.)	Volume (cu ft)	Unit wt (lb)
Radio Receiver R-390/URR-----	1	10½	17¼	19	*2	65
Power Supply PP-621/URR-----	1	5¾	4¼	6¾	-----	15
Power Cable Assembly CX-1358/U (fig. 1)-----	1	-----	-----	96	-----	. 677
Technical manuals-----	2	-----	-----	-----	-----	2
Set of spare tubes-----	1 (31)	-----	-----	-----	-----	-----
Set of spare fuses-----	1 (12)	-----	-----	-----	-----	-----
Set of spare lamps-----	1 (4)	-----	-----	-----	-----	-----
Total-----	-----	-----	-----	-----	2	82. 677

\*Includes Power Supply PP-621/URR.

*Note.* This list is for general information only. See appropriate supply publications for information pertaining to requisition of spare parts.

## 8. Description of Radio Receiver R-390/URR

a. Radio Receiver R-390/URR (fig. 1) is a 33-tube superheterodyne receiver designed for reception of cw, mcw, voice, and radioteletype signals within a frequency range of .5 to 32 mc. The receiver is designed for mounting in a standard 19-inch rack, such as Electrical Equipment Cabinet CY-1119/U. The structural parts of the receiver are of aluminum.

b. All operating controls are located on the front panel (fig. 21), which has a gray semigloss finish. Two handles are provided at the outer

edges of the panel to facilitate withdrawal of the receiver from the rack or case. The two large knobs at the bottom of the panel marked MEGACYCLE CHANGE and KILOCYCLE CHANGE are used to tune the receiver to the desired frequency. Above the KILOCYCLE CHANGE knob is a countertype frequency indicator; the numbers shown indicate the frequency in kilocycles. In the upper left-hand corner of the front panel is a LINE LEVEL meter. In the upper right-hand corner of the front panel is a CARRIER LEVEL meter. Distributed about the panel are 15 bar knobs which control



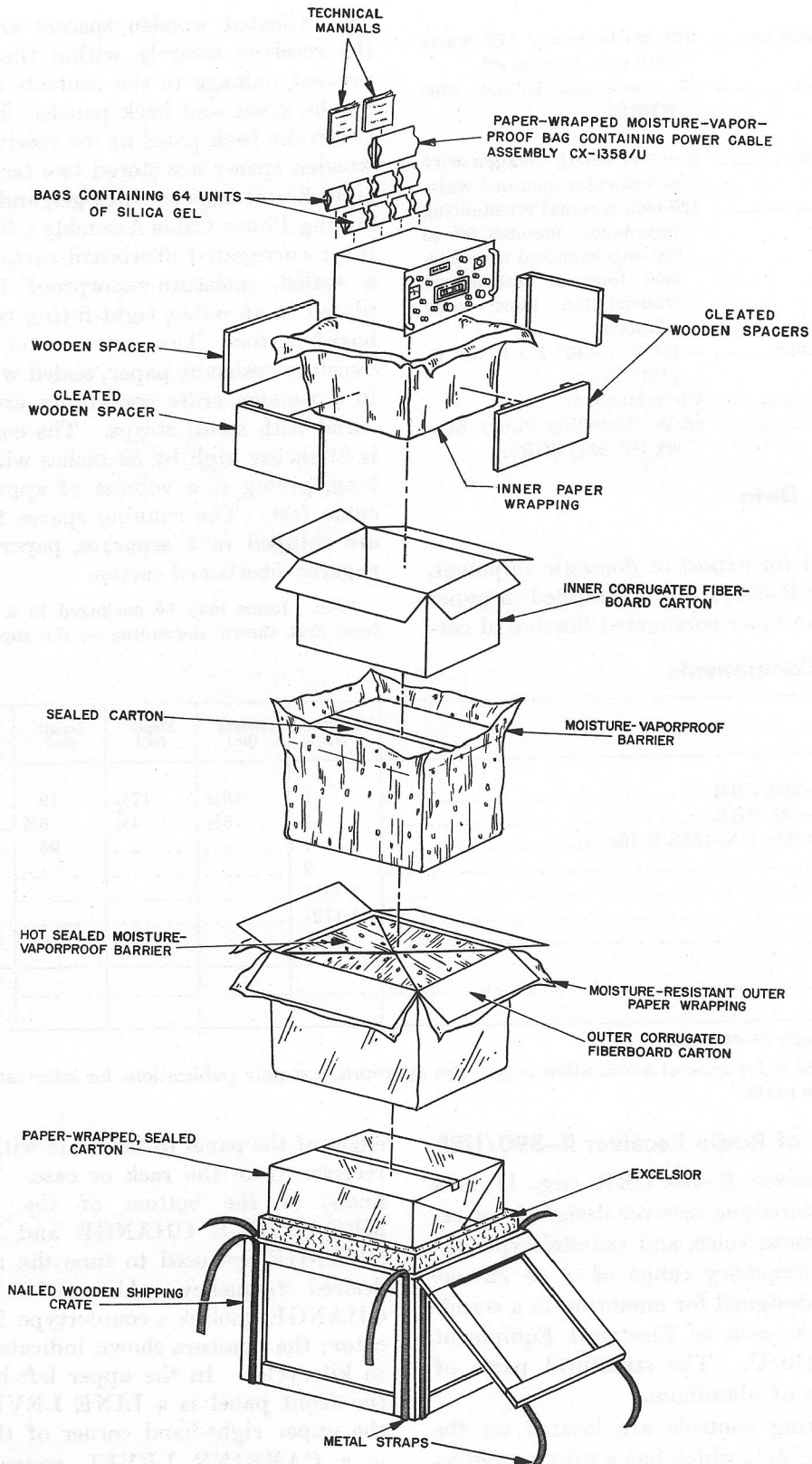

TM 856-5

Figure 6. Radio Receiver R-390/URR, packing and packaging.

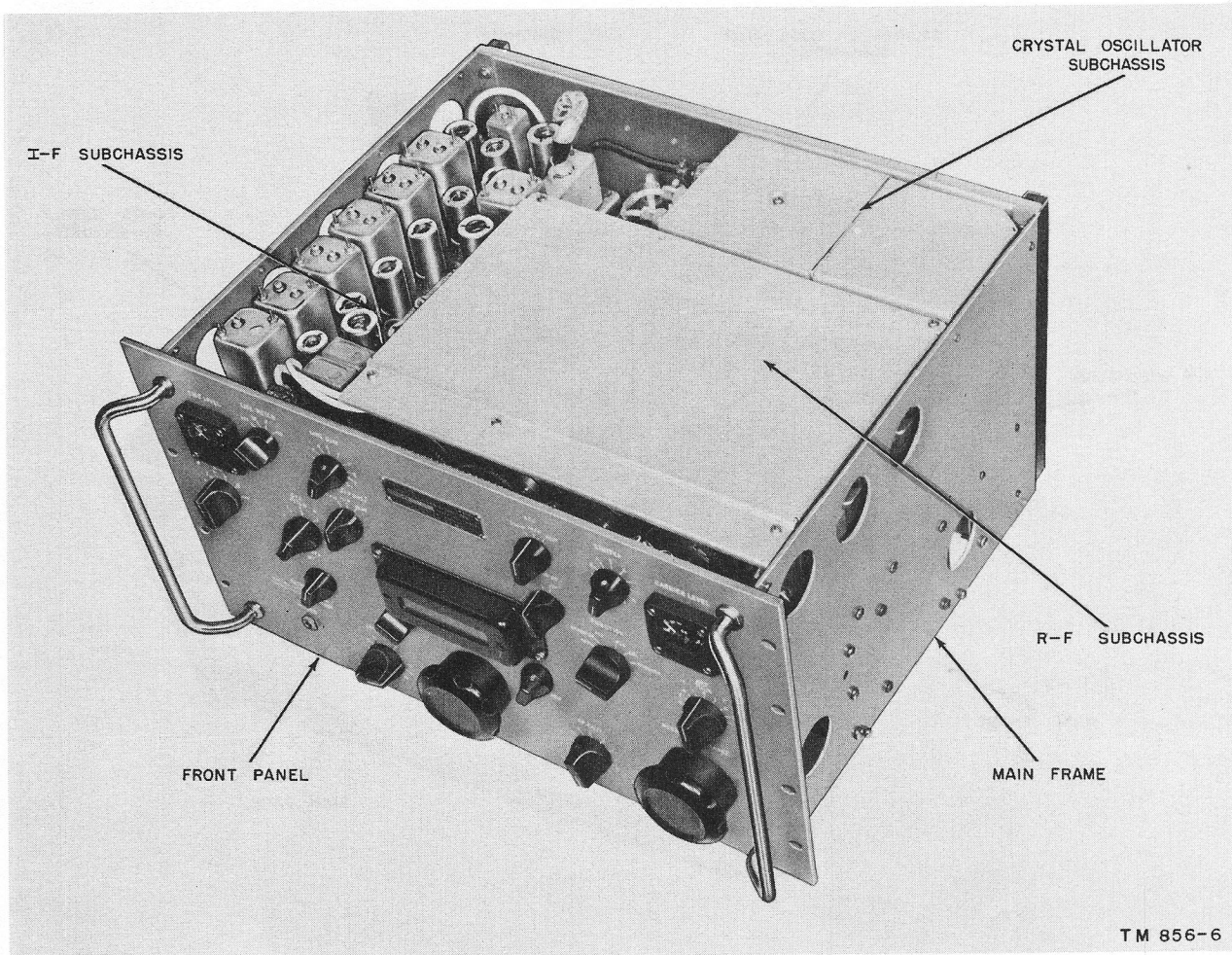

Figure 7. Radio Receiver R-390/URR, top dust cover removed, location of subchassis.

the various functions of the receiver. These controls include the LINE METER switch, LINE GAIN control, AGC time-constant switch, LIMITER off-on switch and threshold control, AUDIO RESPONSE selector switch, BREAK-IN circuit switch, BANDWIDTH selector switch, BFO PITCH control, FUNCTION switch, antenna trimmer (ANT. TRIM) control, BFO OFF-ON switch, DIAL LOCK for KILOCYCLE CHANGE control, frequency-indicator zero-adjustment (ZERO ADJ.) control, LOCAL GAIN control, and RF GAIN control. The PHONES jack in the lower left-hand corner of the panel is provided for connecting a pair of headphones to the receiver local audio output.

c. On the back panel of the receiver (fig. 22) are mounted special tools, ANTENNA input, POWER, REMOTE CONTROL, IF OUTPUT connectors, operating and SPARE FUSES,

OVENS OFF-ON switch, terminal strips for connection of external circuits, and, under a protective cover, trimmer adjustments for the crystal oscillators.

d. Radio Receiver R-390/URR is comprised of a number of interchangeable assemblies (figs. 7 through 16), including the main frame and seven removable subchassis. The rf subchassis, if subchassis, and crystal oscillator subchassis are mounted on the upper deck of the main frame. Mounted in three compartments on the lower deck are the variable frequency oscillator (vfo) subchassis, audio frequency (af) subchassis, calibration-oscillator subchassis, and Power Supply PP-621/URR (alternating current (ac) power supply). The subchassis are connected to the main frame or to each other by cables terminating in locking-type connectors. These subchassis can be removed readily for trouble shooting and repair

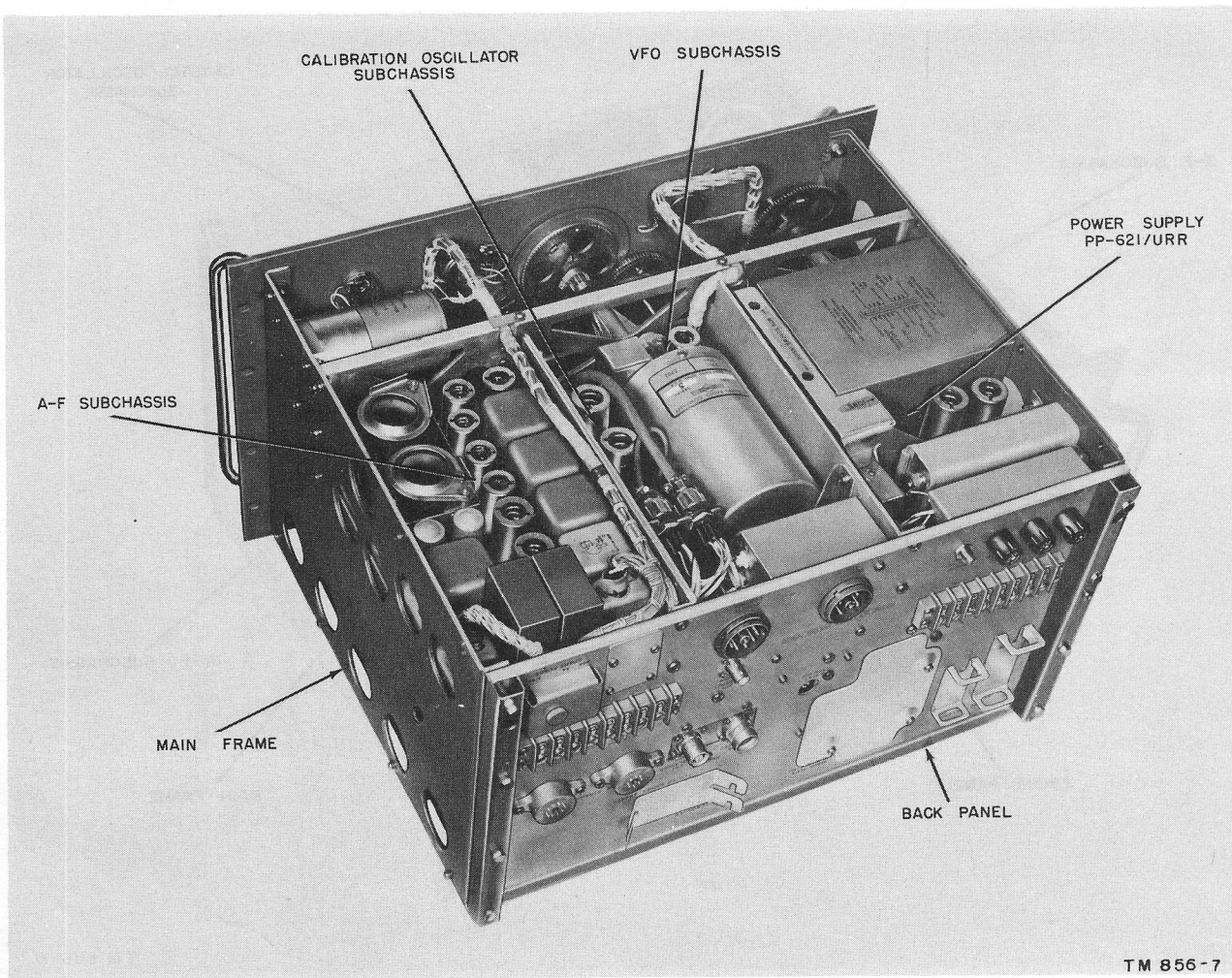

TM 856-7

Figure 8. Radio Receiver R-390/URR, bottom dust cover removed, location of subchassis.

in a minimum of time by the use of ordinary hand tools only.

## 9. Description of Cases and Cabinets Used With Radio Receiver R-390/URR

Two cases and two rack-type cabinets (not supplied) are available for use with the receiver. However, the receiver may be mounted in any standard 19-inch rack, provided that adequate ventilation is furnished and the entire weight of the receiver is not supported by the front panel alone when the receiver is used in mobile service.

a. *Cabinet CY-917/URR.* This is a light-weight, table-top cabinet designed for general fixed-station use.

b. *Case CY-979/URR.* This case is constructed more rigidly than the CY-917/URR,

and embodies shock-absorbing mountings for mobile, table-top installations.

c. *Electrical Equipment Cabinet CY-1119/U.* The electrical equipment cabinet is a floor-mounted, rack-type installation designed for fixed-station use. Seventy inches of panel space are provided for accommodating several components. One-man installation is possible through the use of shelf-type angle brackets.

d. *Electrical Equipment Cabinet CY-1216/U.* This cabinet is of rugged construction and includes shock-absorbing mountings for mobile installations. A panel space of 48 inches is provided for accommodating several components. When either electrical equipment cabinet is used with more than one receiver, always use a 1 $\frac{3}{4}$ -inch blank strip between the receivers to provide adequate ventilation.

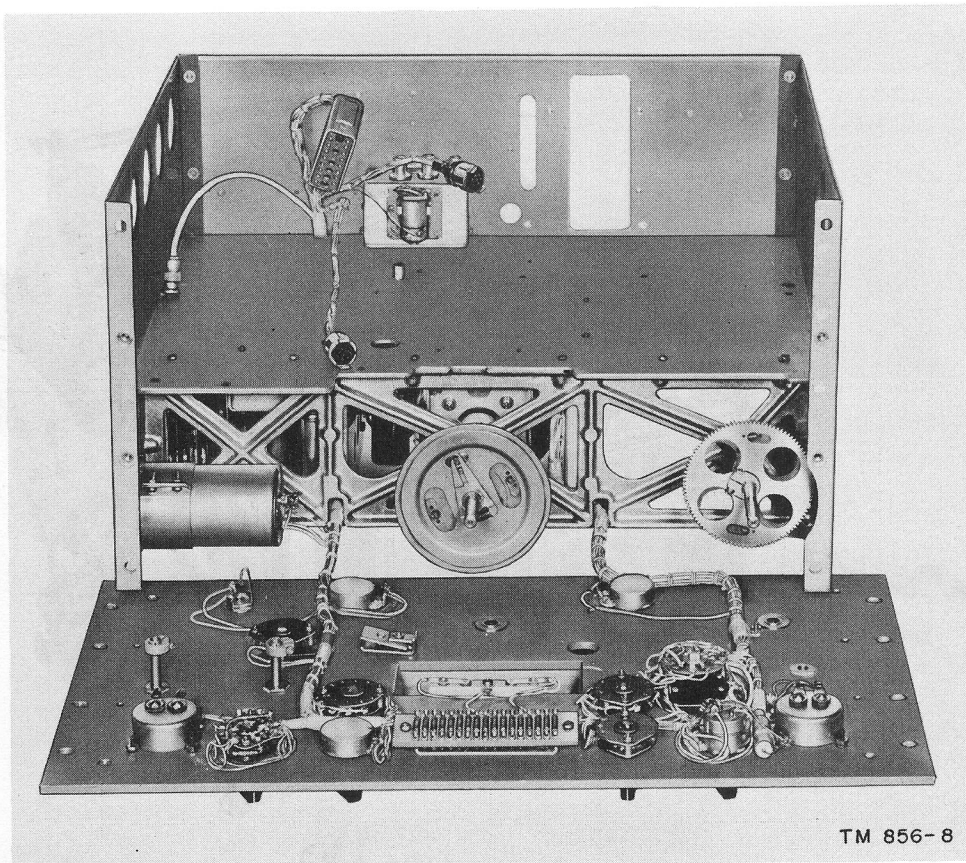

Figure 9. Front panel and main frame.

**Caution:** When Radio Receiver R-390/URR is installed in any case other than those described above, adequate ventilation must be provided. In mobile use, the receiver must be supported in the manner provided in Case CY-979/URR and Electrical Equipment Cabinet CY-1216/U. For mobile applications of the receiver in cabinets other than Case CY-979/URR and Electrical Equipment Cabinet CY-1216/U, support must be provided at the rear of the receiver, so that the front panel does not carry the entire weight.

#### 10. Description of Power Supply PP-621/URR (Ac Power Supply)

(fig. 16)

Power Supply PP-621/URR, which consists of a power transformer, two rectifier tubes, and associated circuits mounted on a removable subchassis, is mounted in a compartment on the lower deck of the main frame. The power supply furnishes the proper voltages for operation of Radio Receiver R-390/URR from a 115- or 230-volt,  $\pm 10$

percent, 48- to 62-cycle source. A switch on the top of the subchassis must be locked in the proper position to connect input power for either 115-volt or 230-volt operation.

#### 11. Description of Power Cable Assembly CX-1358/U (Ac Power Cable)

(fig. 1)

The ac power cable, used when the receiver is operated from a 115-volt or 230-volt ac source, is made up of an 8-foot, two-conductor cable, terminated in a screw-locking plug at one end and a standard parallel-prong ac plug at the other end. The screw-locking plug has a center lead screw for securing the cable plug to the POWER connector of the receiver.

#### 12. Running Spares

A group of running spares is furnished with each receiver. Spares are provided for all normally expendable items such as tubes, dial lamps,

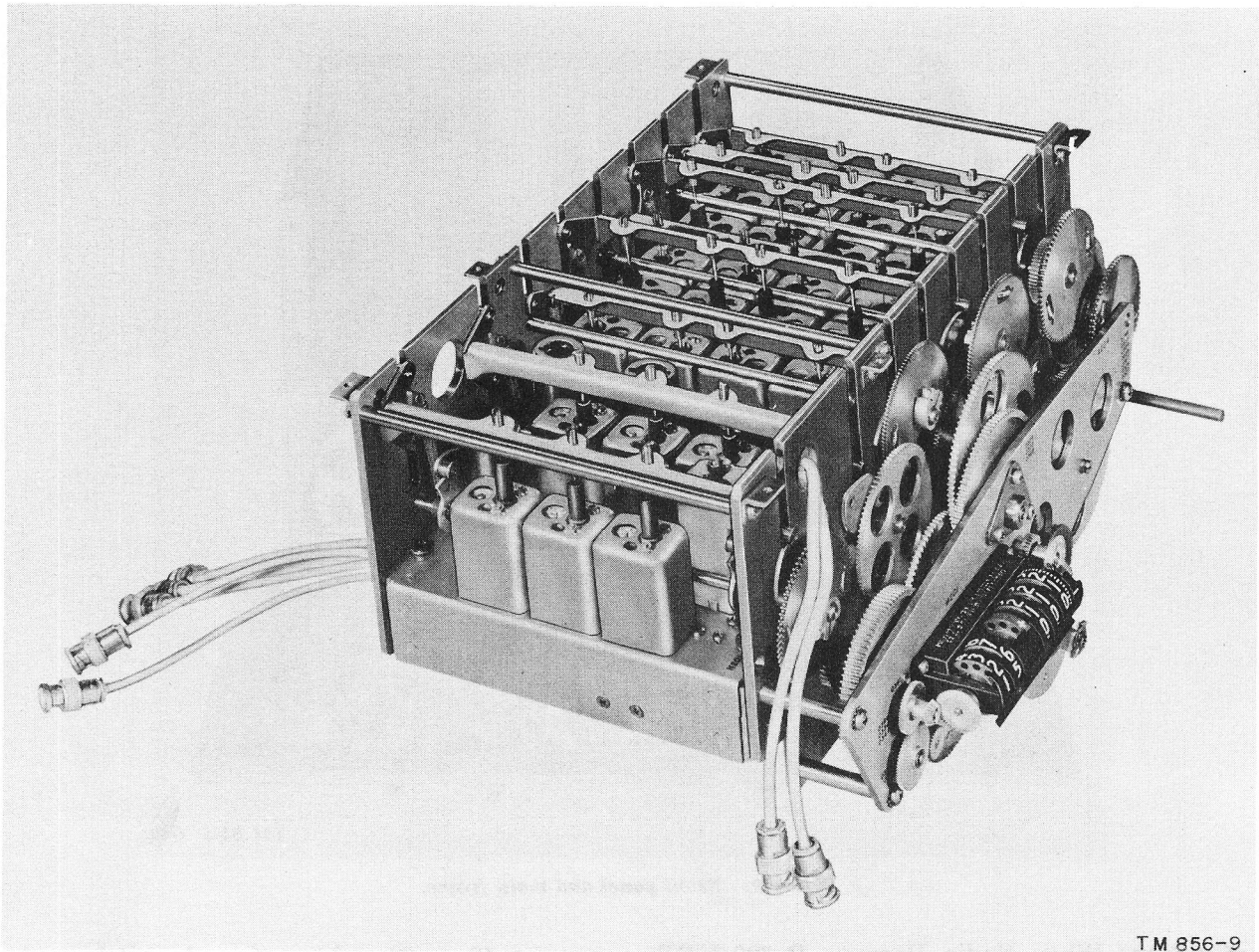

TM 856-9

Figure 10. Rf subchassis.

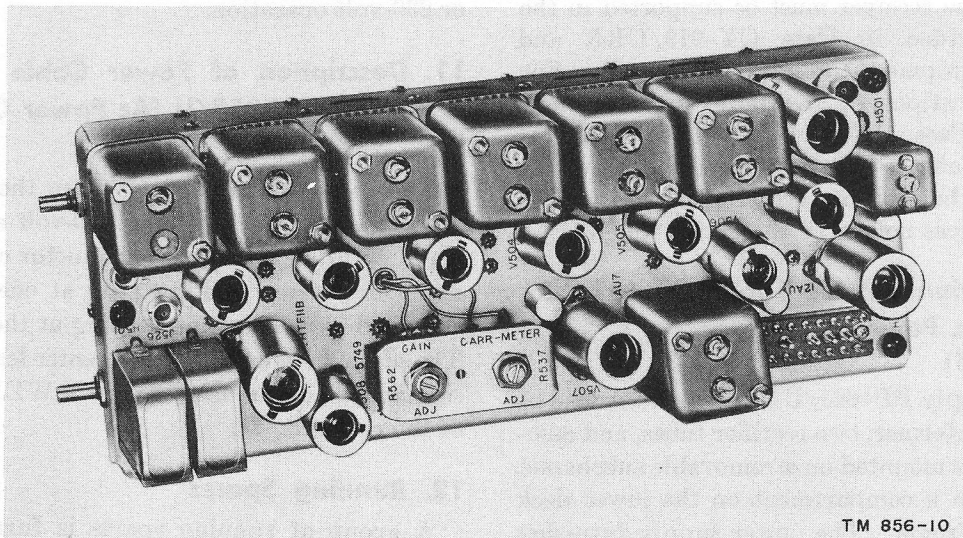

TM 856-10

Figure 11. If subchassis.

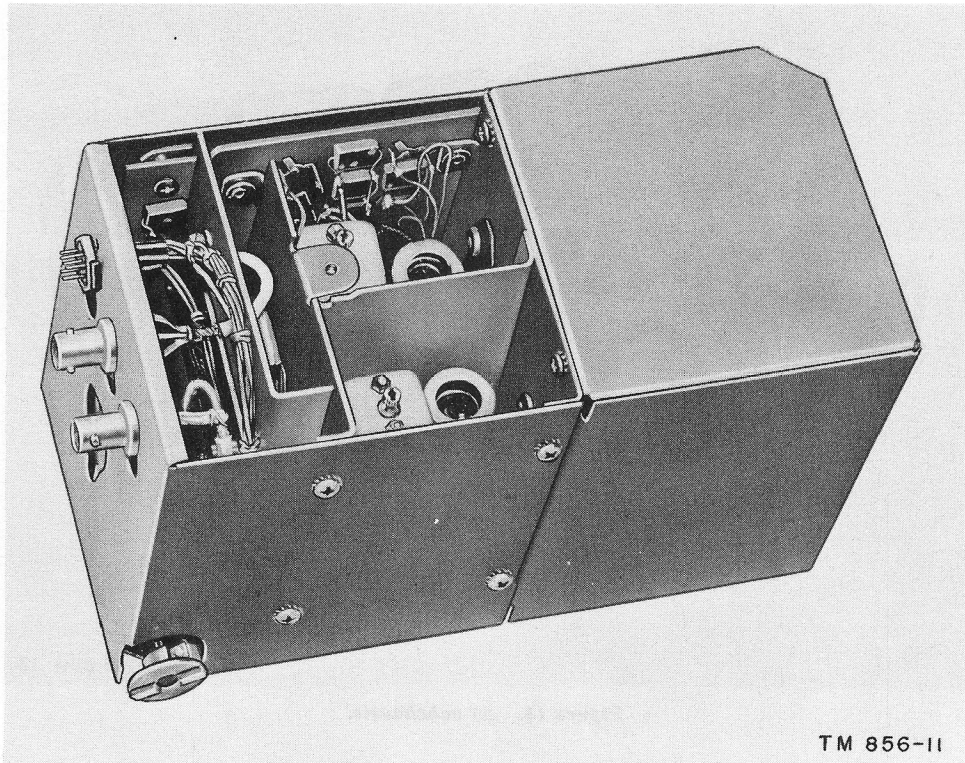

TM 856-11

Figure 12. Crystal-oscillator subchassis.

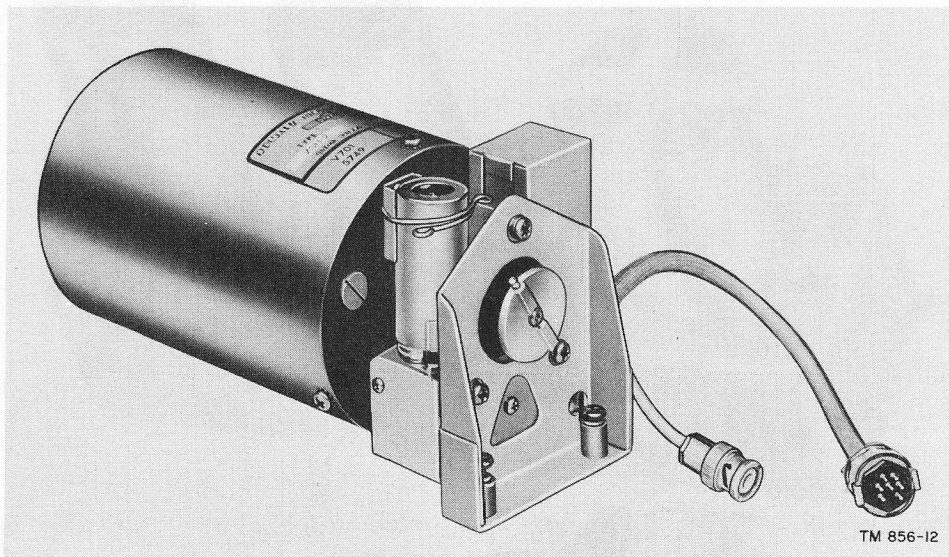

TM 856-12

Figure 13. Vfo subchassis.

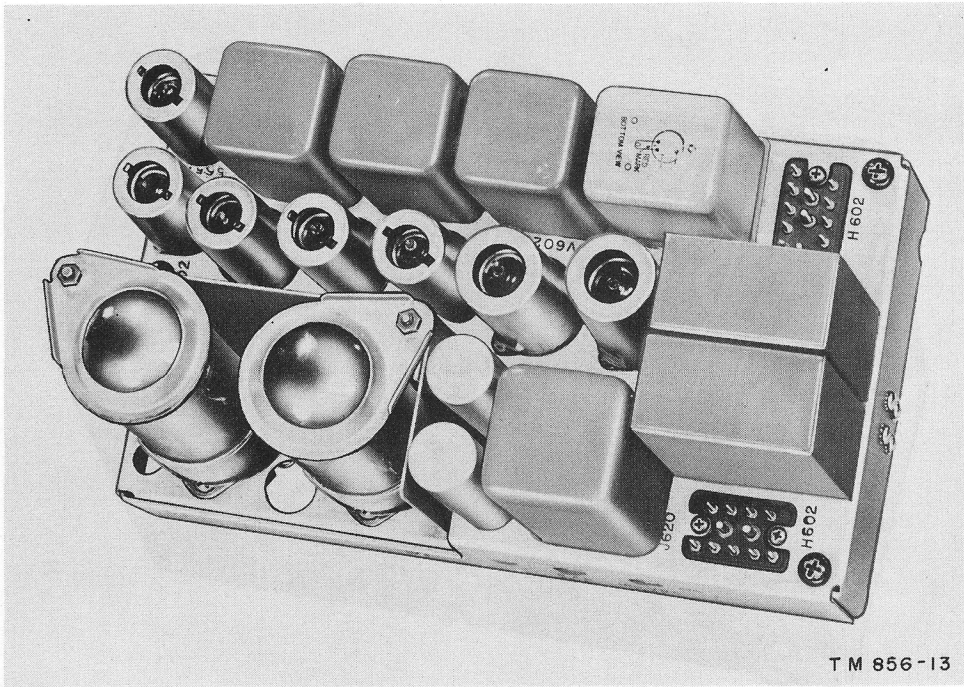

TM 856-13

Figure 14. Af subchassis.

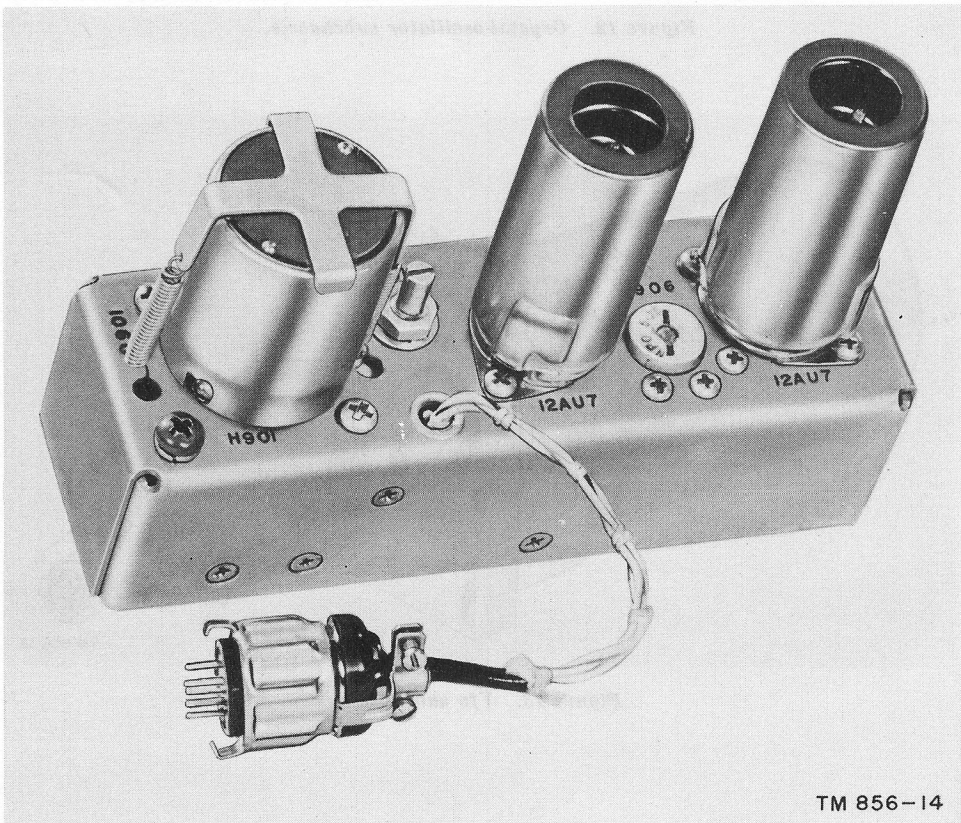

TM 856-14

Figure 15. Calibration-oscillator subchassis.

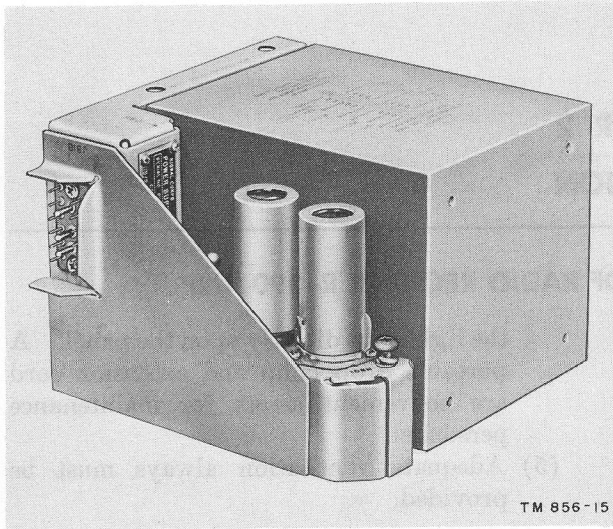

Figure 16. Power Supply PP-621/URR.

and fuses. The following is a list of running spares:

- 2 tubes, type 3TF7.
- 6 tubes, type 6AJ5.
- 2 tubes, type 6AK6.
- 1 tube, type 6BH6.
- 3 tubes, type 6BJ6.
- 2 tubes, type 6C4.
- 1 tube, type 12AT7.
- 3 tubes, type 12AU7.
- 1 tube, type 26Z5W.
- 1 tube, type 5651.

- 4 tubes, type 5749/6BA6W.
- 1 tube, type 6082.
- 4 dial lamps, type GE 327.
- 6 fuses,  $\frac{3}{8}$ -ampere, 125-volt, slow blow, MS type FO2D3ROOB.
- 6 fuses, 3-ampere, 125-volt, slow blow, MS type FO2D3ROOB.

### 13. Additional Equipment Required

The following material is *not* supplied as a part of Radio Receiver R-390/URR but is required for its operation.

#### Antenna :

- Balanced..... Doublet or rhombic.
- Unbalanced..... Straight-wire or random length whip.

#### Low-impedance transmission line :

- Balanced..... 125 or 200 ohms.
- Unbalanced..... 70-ohm coaxial cable.

Headset..... Headset Navy Type CW-49507, or equivalent 600-ohm headset.

Cord..... Headset Cord CX-1334/U, or equivalent.

Speaker..... 600 ohms.

Adapter Connector UG-970/U. Adapts Plug PL-259 on unbalanced antenna lead-in to BALANCED ANTENNA 125 OHM connector J108.

Adapter Connector UG-971/U. Adapts Plug Connector UG-573/U on unbalanced antenna lead in to J108.



## CHAPTER 2

### OPERATION

#### Section I. SERVICE UPON RECEIPT OF RADIO RECEIVER R-390/URR

#### 14. Siting

(fig. 17)

*a. External Requirements.* The location of radio equipment depends on the situation and local requirements, such as the necessity of operating the equipment from an installation where it cannot be seen, from an installation in a vehicle or a shelter, and from an installation which has ready access to messengers. In addition to these factors, the terrain demands consideration before an operating location is decided upon. The prime consideration for establishing the most efficient communication is the location of the antenna. It should be in a location which is high and clear of hills, buildings, cliffs, densely wooded areas, and other obstructions. Depressions, valleys, and other low places are poor sites for radio reception, because the high surrounding terrain absorbs rf energy. Clear, strong signals cannot be expected if the antenna is located under or close to a steel bridge, an underpass, a hospital, a power line, or a power unit. Flat ground having good conductivity is desirable.

*b. Interior Requirements.* If the receiver is to be installed for fixed service, the shelter must meet the following requirements:

- (1) The receiver is to be mounted in Electrical Equipment Cabinet CY-1119/U or in a standard rack.
- (2) For table-top installations, a table or bench capable of supporting the weight of the equipment must be available.
- (3) The receiver must be located in a position convenient to the 115- or 230-volt ac power outlet, if it is to be installed for ac operation.
- (4) Adequate lighting for day and night operation must be provided. Position the receiver so that the panel designations may be read easily by the operating personnel. Install artificial lighting so that

the light falls directly upon the panel. A portable drop lamp and extension cord are convenient assets for maintenance personnel.

- (5) Adequate ventilation always must be provided.

#### 15. Uncrating, Unpacking, and Checking New Equipment

*Note.* For used or reconditioned equipment, refer to paragraph 19.

*a. General.* The equipment is packed identically for both export and domestic shipment. When new equipment is received, select a site where the equipment can be unpacked without exposure to the elements and which is convenient for the installation of the equipment.

**Caution:** Be careful uncrating, unpacking, and handling the equipment. If it becomes damaged, a complete overhaul might be required, or the equipment might be rendered useless.

*b. Uncrating and Unpacking for Export and Domestic Shipments.*

- (1) Place the packing case as near the operating position as is convenient.
- (2) Cut and fold back the metal straps.
- (3) Remove nails with a nail puller. Remove the top and one side of the wooden shipping case. Do not attempt to pry off the side and top, because this might damage the equipment.
- (4) Remove the excelsior covering the paper-wrapped sealed carton inside the crate, and take out the carton.
- (5) Remove the paper covering from the carton, open the outer corrugated fiberboard carton, and withdraw the inner carton inclosed in the moisture-vapor-proof barrier.
- (6) Slit open the seams of the moisture-vaporproof barrier and remove the inner corrugated fiberboard carton.

## SITING

GOOD

HILLTOP, FLAT TERRAIN OR  
NEAR LARGE WATER SURFACE

BAD

NEAR HIGH TENSION WIRES,  
STEEL BRIDGES, OR IN  
VALLEYS OR DEPRESSIONS

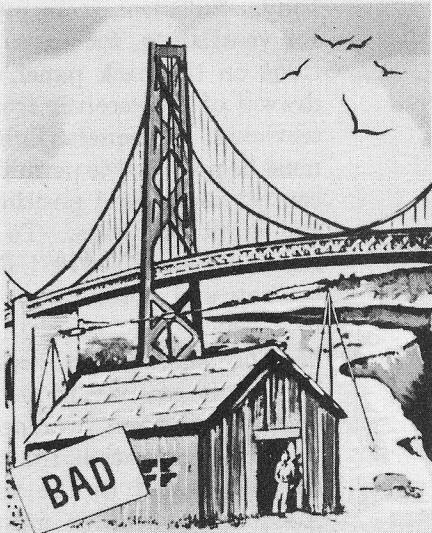
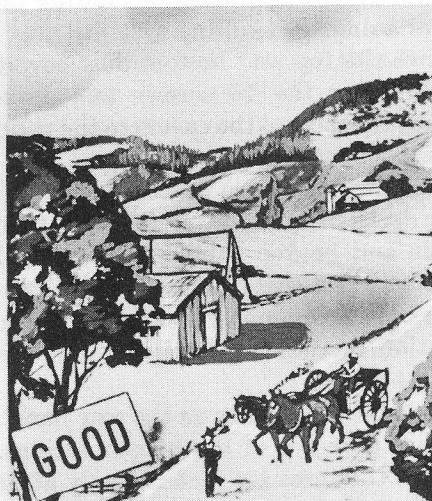

TM 856-93

Figure 17. Siting Radio Receiver R-390/URR.

- (7) Open the inner carton and remove the four wooden spacers from the inner carton.
- (8) Remove the bags of silica gel, the technical manuals, and the package containing the power cord from the space at the rear of the receiver.
- (9) Withdraw the paper-wrapped receiver from the inner carton, place it on a work bench or near its final location, and remove the paper wrapping.

### c. Checking.

- (1) Check the contents of the cartons against the master packing slip.
- (2) Check the front panel of the receiver for damage to the knobs or to glass windows of the meters and frequency-indicator dial.
- (3) Operate the control knobs; examine them for looseness. Operate the MEGA-CYCLE CHANGE and KILOCYCLE CHANGE knobs throughout their

ranges. Rough operation or binding indicates a damaged tuning system.

- (4) Remove the top and bottom dust covers by removing the 16 screws and lock-washers that secure the covers to the main frame.
- (5) Inspect the subchassis on the upper and lower decks of the receiver for loose tube shields and broken tubes. See that all connectors are seated firmly; loose connectors are a common cause of improper operation in radio equipment. Replace the dust covers.
- (6) Remove the three fuses on the rear panel. See that they are of the proper ratings. See that the fuses are seated firmly after replacing them.

**Caution:** To avoid serious damage to the receiver, do not use any fuse rated above the value specified.

- (7) Inspect for bent or broken connectors and terminals on the rear panel. See that all special tools are in place in their holders (fig. 22). Remove the small cover at the lower right-hand corner. See that spare fuses of proper ratings are in place.
- (8) Check the contents of the box containing the running spares for damaged parts.

## 16. Installation

*a. Antenna.* Radio Receiver R-390/URR is normally used with rhombic, doublet, or double-doublet antennas. For information on the rhombic and doublet antennas, refer to TM 11-666, Antennas and Radio Propagation. For information on the double-doublet antenna, refer to TM 11-2629, Antenna Kit for Double-Doublet Receiving Antenna.

*b. Radio Receiver R-390/URR.* Radio Receiver R-390/URR is shipped with all tubes, crystals, and fuses in place, and no further internal installation is required. Instructions for installing the receiver for fixed and mobile use are listed in (1) through (4) below. If the radio receiver is used as part of a system, refer to the system technical manual for exact installation instructions.

- (1) *Fixed, table-top installation.* When housed in Cabinet CY-917/URR or a similar well-ventilated case for fixed

operation, the receiver can be placed on any sturdy table or bench.

- (2) *Fixed, cabinet installation.* To install the receiver in a standard cabinet, such as Electrical Equipment Cabinet CY-1119/U, remove the top and bottom dust covers of the receiver. Remove one of the blank panels from the cabinet and install the receiver. Secure the front panel to the cabinet with the bolts removed from the blank panel. Insert them in the elongated holes located along the vertical edges of the receiver front panel.

- (3) *Mobile, table-top installation.* When the receiver is housed in Case CY-979/URR for mobile operation, the case must be securely bolted to a table or shelf which is fastened rigidly to the vehicle body. Sufficient room must be allowed for ventilation, for access to the connections on the back panel, and for withdrawal of the receiver from the case for servicing. Adequate lighting facilities must be provided to permit reading of the control names and positions during day and night operation. To install the receiver in Case CY-979/URR first remove the top and bottom dust covers of the receiver.

- (4) *Mobile, cabinet or rack installation.* When the receiver is installed in Electrical Equipment Cabinet CY-1216/U for mobile operation, the cabinet must be securely bolted to the vehicular body. Adequate ventilation must be provided, and sufficient room must be allowed for access to back panel connections and for withdrawal of the receiver for servicing. Provision for lighting must be made to permit reading of control names and positions during day and night operation.

## 17. Connections

Each Radio Receiver R-390/URR is shipped with jumpers between terminals 1 and 2, 3 and 4, 11 and 12, and 14 and 15. These four jumpers are required for normal operation. If the radio receiver is used as part of a system, refer to the system technical manual for exact connections.

**Warning:** The voltages used are sufficiently high to endanger human life. To prevent shock

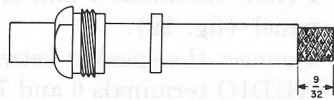
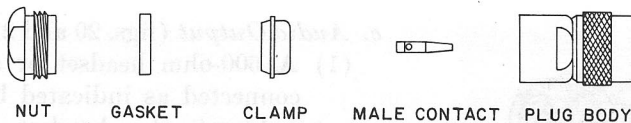

- SLIDE NUT AND GASKET OVER CABLE.  
 1 REMOVE VINYL JACKET FOR  $\frac{9}{32}$  INCH.  
 DO NOT NICK BRAID.

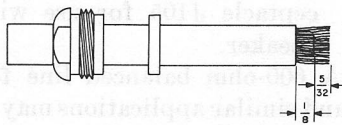

- 2 COMB OUT BRAID AND FOLD OUT.  
 2 CUT DIELECTRIC TO  $\frac{1}{8}$  INCH AND  
 BARE CENTER CONDUCTOR  $\frac{5}{32}$  INCH.

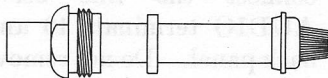

- 3 PULL BRAID FORWARD AND TAPER  
 SLIDE CLAMP OVER BRAID.

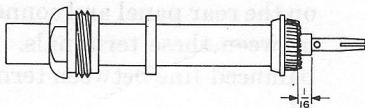

- 4 FOLD BACK BRAID, TRIM TO PROPER  
 LENGTH AND FORM OVER CLAMP AS  
 SHOWN. SOLDER CONTACTS TO CENTER  
 CONDUCTOR, NOTE  $\frac{1}{16}$  INCH DIMENSION.

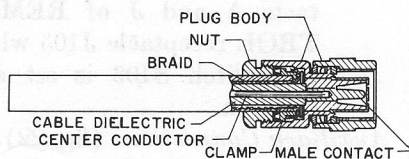

- 5 INSERT CABLE AND PARTS INTO CONNECTOR BODY.  
 MAKE SURE SHARP EDGE OF CLAMP SEATS  
 PROPERLY IN GASKET. END OF CONTACT SHOULD  
 BE FLUSH WITH INSULATION.

TM 856-20

Figure 18. Assembly of Plug Connector UG-573/U to a coaxial cable.

hazard for personnel touching outside metallic parts of the receiver, connect terminal 16 (marked GND) on the rear panel (fig. 22) to ground.

a. *Power Input* (fig. 20). For 115- or 230-volt, 48- to 62-cps operation, connect Power Cable Assembly CX-1358/U between the power source and POWER receptacle J104.

**Caution:** Check to see that 115 VAC/230 VAC switch S801 (fig. 88), on Power Supply PP-621/URR, is in the proper position for operation of the receiver from the available power source. The switch is reached easily when the dust cover is removed from the bottom of the receiver. When

the receiver is operated from a 230-volt power source, change the fuse marked AC 3A (fig. 20) from a 3-ampere, 125-volt type (MS type FO2D3ROOB) to a 3-ampere, 250-volt type (MS type FO2G3ROOA).

b. *Antenna* (fig. 18, 19, and 20). The antenna is connected to either the UNBALANCED WHIP or BALANCED ANTENNA 125 OHM connector on the back panel (fig. 22) as follows:

(1) *UNBALANCED WHIP connector.*

When a whip antenna is to be used for vehicular installations, or a random length wire is to be used in fixed installa-

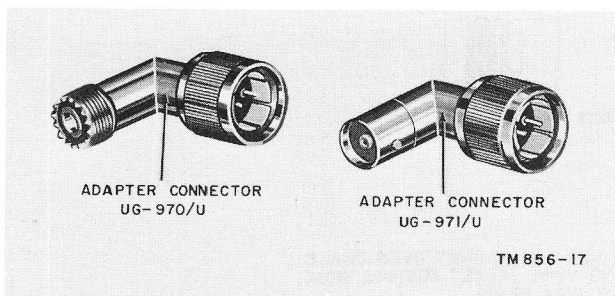

Figure 19. Adapter Connectors UG-970/U and UG-971/U.

tions, the lead-in must be connected to UNBALANCED WHIP connector J107 (Receptacle Connector UG-568/U).

- (a) Assemble Plug Connector UG-573/U to the coaxial transmission line as indicated in figure 18. (The whip antenna lead-in should be as short a length as possible of Radio Frequency Cable RG-8/U or RG-11/U.)
  - (b) Connect the terminated transmission line to UNBALANCED WHIP connector J107.
- (2) **BALANCED ANTENNA 125 OHM connector.** BALANCED ANTENNA 125 OHM connector J108 (Receptacle Connector UG-422/U) furnishes input to the receiver through a tuned antenna transformer. This connector is used for all balanced antennas, such as a balanced doublet, and should be used for unbalanced low-impedance transmission lines.
- (a) Connect the balanced coaxial Cable RG-22/U from 50 to 200-ohm balanced antennas to J108 with Plug Connector UG-421/U, or when Cable RG-86/U transmission line is used, connect with Plug Connector UG-969/U.
  - (b) Two right-angle adapters are available for connecting unbalanced coaxial cable to the BALANCED ANTENNA 125 OHM connector. Adapter Connector UG-970/U adapts unbalanced coaxial lead-in terminated in Plug PL-259 to the connector, while Adapter Connector UG-971/U is used to connect unbalanced coaxial lead-in terminated in Plug Connector UG-573/U. Adapter Connector UG-971/U and Plug Connector UG-573/U are preferred and should be used when available.

c. *Audio Output* (figs. 20 and 21).

- (1) A 600-ohm headset or speaker may be connected as indicated below:
  - (a) Insert the headset plug into the PHONES jack on the front panel (fig. 21), or connect the headset between PHNS terminals 7 and 8, on the back panel (fig. 22).
  - (b) Connect the speaker between LOCAL AUDIO terminals 6 and 7 on the back panel.
  - (c) LOCAL AUDIO output is available at pin H of REMOTE CONTROL receptacle J105 for use with a remote speaker.
- (2) A 600-ohm balanced line for telephone and similar applications may be connected as follows:
  - (a) For normal balanced-line operation, connect the line between LINE AUDIO terminals 10 and 13 on the back panel. Do not remove the jumper on terminals 11 and 12.
  - (b) If a balancing bridge is to be used for long-distance line applications, remove the jumper from terminals 11 and 12 on the rear panel and connect the bridge between these terminals. Connect the balanced line between terminals 10 and 13.
  - (c) Line audio output is available at contacts A and J of REMOTE CONTROL receptacle J105 when BREAK IN switch S106 is set at the OFF position.

d. *Auxiliary Connections* (fig. 22).

- (1) *Break-in relay.* Connection to the break-in relay is completed through contact B of REMOTE CONTROL receptacle J105 or BRK IN terminal 9 on rear panel. The break-in relay operates to disable the receiver when the BREAK IN switch on the front panel is set at ON and BRK IN terminal 9 on the rear panel or contact B of J105 is grounded remotely.
- (2) *Carrier control.* Connection for carrier control of an external circuit is completed through contact K of REMOTE CONTROL receptacle J105. When the BREAK IN switch is set at OFF and the FUNCTION switch is set at SQUELCH, the carrier control circuit

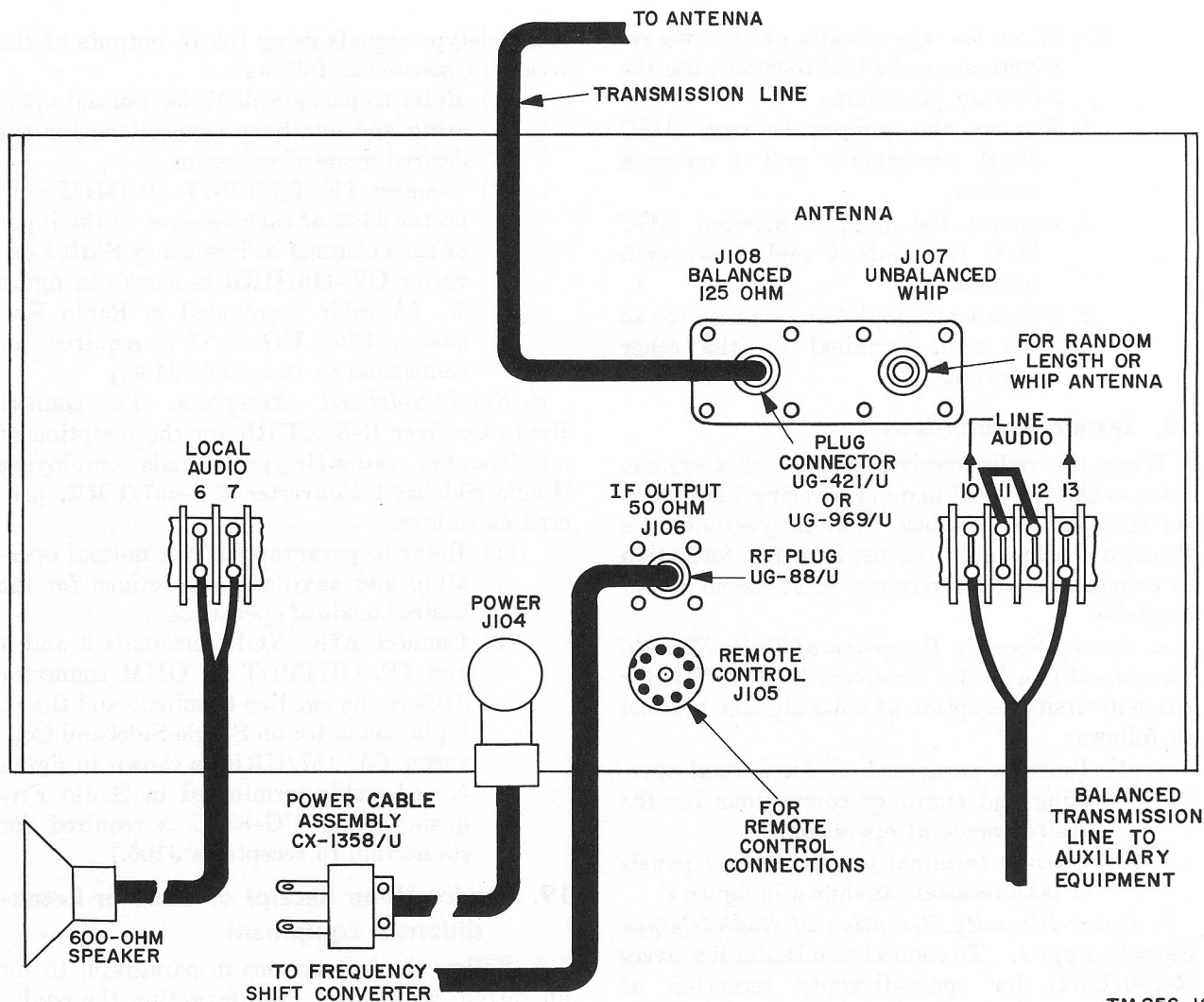

TM 856-16

Figure 20. Radio Receiver R-390/URR, cording diagram.

is grounded whenever a carrier signal is being received.

- (3) *Sidetone.* Sidetone is applied to the output of the receiver by connecting the sidetone circuit to contacts H and E (ground) of the REMOTE CONTROL receptacle.
- (4) *External diode load.* DIODE LOAD terminals 14 and 15 on the rear panel are provided to facilitate detector diode-load combining for diversity reception. Terminals 14 and 15 must be connected together for normal receiver operation.
- (5) *External rf gain control.* For external control of the rf gain of the receiver, the internal RF GAIN control is discon-

nected and a 5,000-ohm potentiometer is connected externally. To substitute the external control for the internal RF GAIN control, remove the jumper between RF GAIN terminals 1 and 2 on rear panel and connect the external control between terminal 1 and terminal 7 (ground).

- (6) *Agc circuit.*
  - (a) For external agc of the receiver, remove the jumper between AGC NOR terminals 3 and 4 on rear panel, connect the negative terminal of the source to terminal 4, and connect the other terminal of the source to terminal 7 (ground).

(b) When the agc circuits of the two receivers are to be tied together, use the following procedure:

1. Remove the jumper between AGC NOR terminals 3 and 4 on each receiver.
2. Connect the jumper between AGC DIV terminals 4 and 5 on each receiver.
3. Connect terminal 4 on one receiver to the same terminal on the other receiver.

## 18. System Connections

When the radio receiver is part of a system, refer to the technical manual covering the system for the exact connections. The instructions in *a* through *d* below are to be used when information to connect the radio receiver in a system is not available.

*a. Space-Diversity Reception of Voice Signals.* To connect two Radio Receivers R-390/URR for space-diversity reception of voice signals, proceed as follows:

- (1) Refer to paragraph 17 for normal operating and auxiliary connections for the desired mode of operation.
- (2) Connect terminal boards on rear panels of both receivers as shown in figure 2.

*b. Space-Diversity Reception of Radioteletype Signals, Type 1.* To connect two Radio Receivers R-390/URR for space-diversity reception of radioteletype signals using the audio output of the receivers, proceed as follows:

- (1) Refer to paragraph 17 for normal operating and auxiliary connections for the desired mode of operation.
- (2) Connect LINE AUDIO terminals 10 and 13 of each receiver to the input of each channel in Radioteletype Terminal Equipment AN/FGC-1( ) as shown in figure 3.

*c. Space-Diversity Reception of Radioteletype Signals, Type 2.* To connect two Radio Receivers R-390/URR for space-diversity reception of

radioteletype signals using the if. outputs of the receivers, proceed as follows:

- (1) Refer to paragraph 17 for normal operating and auxiliary connections for the desired mode of operation.
- (2) Connect IF. OUTPUT 50 OHM connector J106 of each receiver to the input of each channel in Frequency Shift Converter CV-116/URR as shown in figure 4. (A cable terminated in Radio Frequency Plug UG-88/U is required for connection to receptacle J106.)

*d. Single-Sideband Reception.* To connect Radio Receiver R-390/URR for the reception of multichannel radioteletype signals employing Single Sideband Converter CV-157/URR, proceed as follows:

- (1) Refer to paragraph 17 for normal operating and auxiliary connections for the desired mode of operation.
- (2) Connect AGC NOR terminals 3 and 4 and IF. OUTPUT 50 OHM connector J106 to the agc line terminals and the if. input connector on Single Sideband Converter CV-157/URR as shown in figure 5. (A cable terminated in Radio Frequency Plug UG-88/U is required for connection to receptacle J106.)

## 19. Service Upon Receipt of Used or Reconditioned Equipment

*a.* Follow the instructions in paragraph 15 for uncrating, unpacking, and inspecting the equipment.

*b.* Examine the used or reconditioned equipment for tags or other indications pertaining to changes in the wiring of the equipment. If any changes in the wiring have been made, note the change in this technical manual, preferably on the schematic diagrams.

*c.* Check the MEGACYCLE CHANGE and KILOCYCLE CHANGE knobs for ease of rotation. If lubrication is required, refer to the lubrication instructions in paragraph 106.

*d.* Perform the installation and connection procedures given in paragraphs 16, 17, and 18.

## Section II. CONTROLS AND INSTRUMENTS

### 20. General

Haphazard operation or improper setting of the controls can cause damage to the receiver. For

this reason, it is important to know the function of every control. The actual operation of the equipment is discussed in paragraphs 22 through 28.

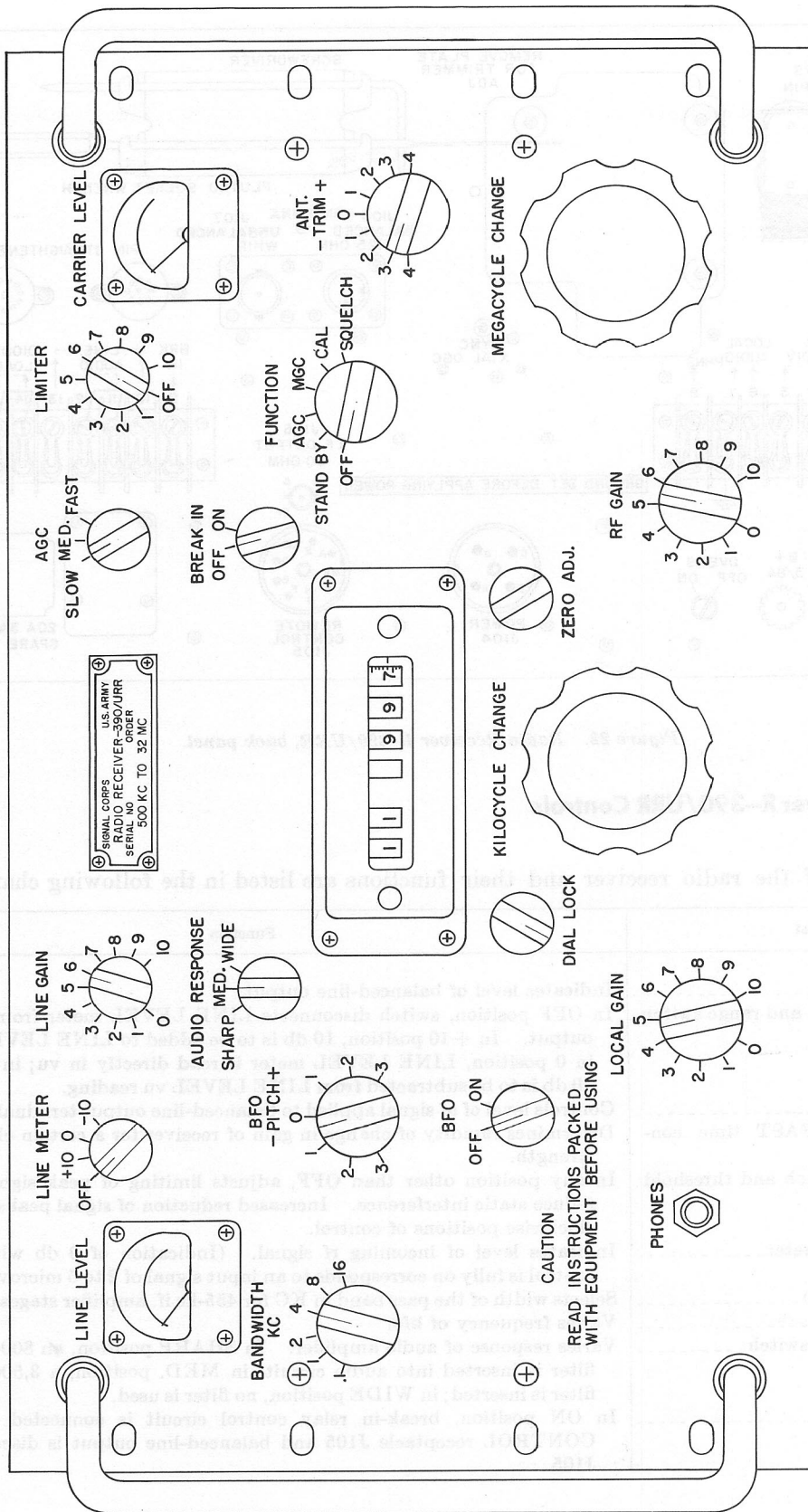

TM 856-19

Figure 21. Radio Receiver R-390/URR, front panel.



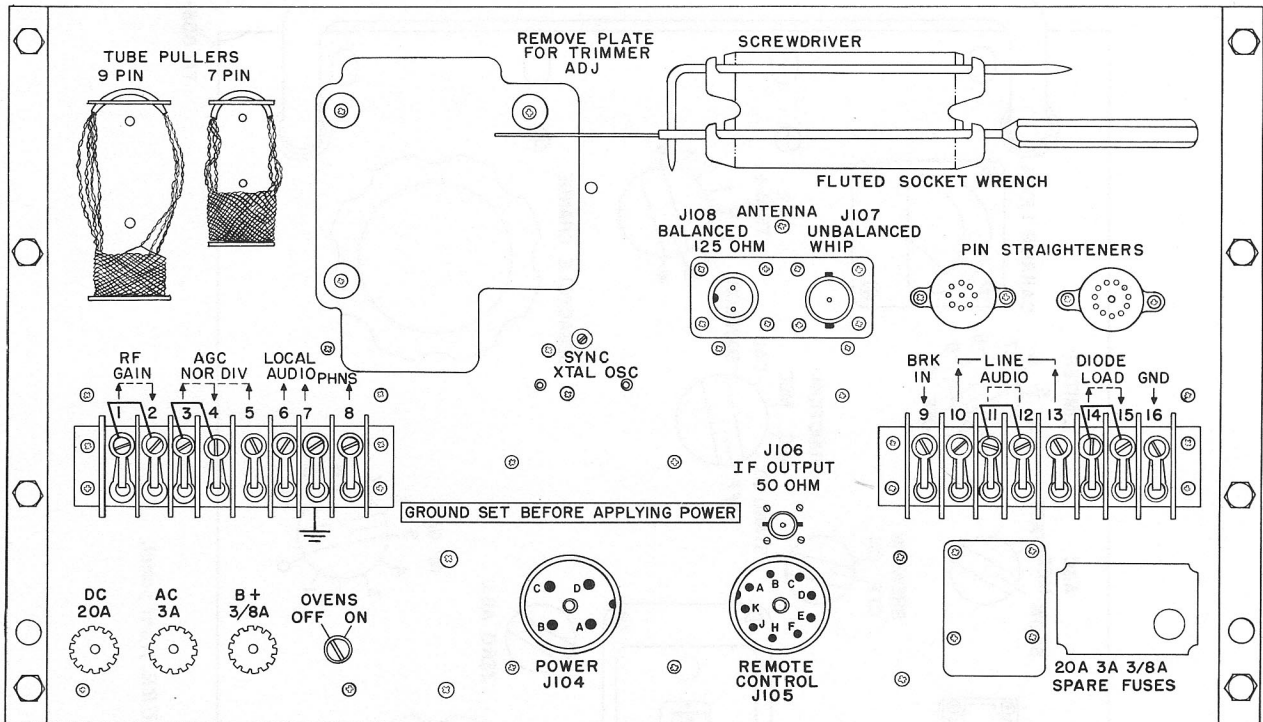

TM 856-18

Figure 22. Radio Receiver R-390/URR, back panel.

## 21. Radio Receiver R-390/URR Controls

(fig. 21)

The controls of the radio receiver and their functions are listed in the following chart:

Control	Function
LINE LEVEL meter.....	Indicates level of balanced-line output.
LINE METER off-on and range switch.....	In OFF position, switch disconnects LINE LEVEL meter from balanced-line output. In +10 position, 10 db is to be added to LINE LEVEL vu reading; in 0 position, LINE LEVEL meter is read directly in vu; in -10 position, 10 db is to be subtracted from LINE LEVEL vu reading.
LINE GAIN control.....	Controls level of af signal applied to balanced-line output terminals.
AGC SLOW-MED.-FAST time constant switch.....	Determines rapidity of change in gain of receiver for a certain change of signal strength.
LIMITER off-on switch and threshold control.....	In any position other than OFF, adjusts limiting of peak signal impulses to reduce static interference. Increased reduction of signal peaks is obtained at clockwise positions of control.
CARRIER LEVEL meter.....	Indicates level of incoming rf signal. (Indication of 0 db when RF GAIN control is fully on corresponds to an input signal of 2 to 5 microvolts.)
BANDWIDTH switch.....	Selects width of the pass band in KC for 455-kc if. amplifier stages.
BFO PITCH control.....	Varies frequency of bfo.
AUDIO RESPONSE switch.....	Varies response of audio amplifier. In SHARP position, an 800-cps band-pass filter is inserted into audio circuit; in MED. position, a 3,500-cps low-pass filter is inserted; in WIDE position, no filter is used.
BREAK IN switch.....	In ON position, break-in relay control circuit is connected to REMOTE CONTROL receptacle J105 and balanced-line output is disconnected from J105.

Control	Function		
FUNCTION switch.....	When rotated to any position other than OFF, connects receiver to power source and selects desired receiver function. The positions and functions are as follows:		
	<table border="0"> <tr> <td style="text-align: center;"><i>Position</i></td> <td style="text-align: center;"><i>Function</i></td> </tr> </table>	<i>Position</i>	<i>Function</i>
<i>Position</i>	<i>Function</i>		
STAND BY.....	Receiver disabled but filaments remain lighted and oscillators remain on; receiver ready for instant use.		
AGC.....	Gain is controlled automatically for normal reception.		
MGC.....	Agc disabled; gain is controlled manually by RF GAIN control or an external gain control.		
CAL.....	Calibration oscillator functions to supply signals at 100-kc points.		
SQUELCH.....	Squelch circuit is connected for silencing receiver when input signal falls below threshold level determined by setting of RF GAIN control.		
ANT. TRIM control.....	Provides means of tuning antenna circuit for maximum signal input.		
BFO OFF-ON switch.....	In ON position, places bfo in operation.		
DIAL LOCK control.....	Locks KILOCYCLE CHANGE control to prevent accidental change of setting.		
ZERO ADJ. control.....	When turned clockwise, disengages frequency indicator from KILOCYCLE CHANGE control for calibration purposes.		
LOCAL GAIN control.....	Controls level of af signal applied to local output terminals.		
RF GAIN control.....	Controls gain of rf and if. amplifiers. When squelch circuit is operative, controls squelch threshold and permits maximum agc when in the maximum clockwise position.		
MEGACYCLE CHANGE control.....	Selects any one of 32 tuning steps; changes reading of first two digits of frequency indicator.		
KILOCYCLE CHANGE control.....	Tunes receiver to any frequency within a band, and changes reading of last three digits on frequency indicator. Frequency range of control is slightly greater than 1 mc. When tuned to a frequency higher or lower than that indicated by first two digits, plus or minus sign is displayed in space between mc and kc readings. A plus sign indicates addition, and a minus sign indicates subtraction of 1 mc in reading of first two digits to obtain a true reading.		
PHONES jack.....	Provides means of connecting a headset to the receiver.		
OVENS OFF-ON switch (fig. 22).....	Screw-driver adjustment. In ON position, 26 volts ac are applied to crystal oven HR401 and vfo oven HR701.		
Fuse AC 3A (fig. 22).....	Protects power input circuit components.		
Fuse B + 3/8A (fig. 22).....	Protects high-voltage circuit components.		

### Section III. OPERATION UNDER USUAL CONDITIONS

**Warning:** The voltages employed are sufficiently high to endanger human life. Every precaution should be taken by personnel to minimize the danger of shock. See that GND terminal 16 on rear panel (fig. 22) is grounded.

#### 22. Starting Procedure

**Caution:** The ac power supply of the receiver must be set to the correct ac input voltage. Refer to paragraph 17. Make sure that all of the external connections to the receiver are satisfactory for the desired type of operation outlined in paragraphs 17 and 18.

a. If the radio receiver is operated under low-temperature conditions, or in a location where there is considerable variation in temperature, set the screwdriver-adjusted OVENS ON-OFF switch on the back panel to ON. When the set is operated in a temperature-regulated building or when maximum frequency stability is not required, set OVENS ON-OFF switch to OFF. When the receiver is secured in the cabinet and is protected by dust, remove the top and bottom dust covers of the receiver to provide adequate ventilation.

b. Turn the FUNCTION switch to AGC. Before operating the receiver, allow it to warm up for several minutes.

### 23. Reception of Voice Signals

a. Set front panel controls to positions indicated: BFO to OFF, LINE GAIN to 0, RF GAIN to 10, LOCAL GAIN to 5, BANDWIDTH to 8 KC, AUDIO RESPONSE to MED., AGC to MED., LIMITER to OFF, and disengage the DIAL LOCK control.

b. With the MEGACYCLE CHANGE AND KILOCYCLE CHANGE controls, set frequency-indicator reading to frequency of desired station. If a plus or minus sign appears in the space between the megacycle and kilocycle readings on the dial (because of over-travel of the KILOCYCLE CHANGE control) when tuning in an unknown station, the reading of the first two digits must be increased or decreased, respectively, by 1 mc to arrive at the true frequency. To maintain tuning accuracy of at least 3 kc, calibrate the dial as directed in paragraph 26 each time the MEGACYCLE CHANGE control is operated to select another band.

c. Adjust the KILOCYCLE CHANGE and ANT. TRIM controls for maximum reading on the CARRIER LEVEL meter.

d. Tighten the DIAL LOCK to prevent changing of frequency setting.

e. Adjust the LOCAL GAIN control for desired volume level.

f. If noise is excessive, rotate the LIMITER control clockwise as needed.

g. When the signal fades rapidly, set the AGC switch to FAST.

h. If interference is encountered, set the BANDWIDTH switch to the 4-KC position, or, if necessary, to the 2-KC position.

i. When it is desired to quiet the receiver between transmissions, set the FUNCTION switch to SQUELCH and rotate the RF GAIN control counterclockwise from the full-on position to reduce high-level noise. Avoid reducing gain to such an extent that the desired signal is also eliminated.

*Note.* Do not use SQUELCH if the desired signals are weak or subject to fading.

j. When the balanced-line output circuit is being used to feed the telephone line or other equipment, set the LINE METER switch to the required range and adjust the LINE GAIN control for desired reading on the LINE LEVEL meter, normally at 0-VU.

k. If the break-in relay is connected to the transmitter control circuits and the receiver is to be disabled during periods of transmission, set the BREAK IN switch to ON.

### 24. Reception of CW and MCW Signals

Operate the receiver controls in the same manner as for voice reception, with the following exceptions:

a. Set the BFO switch to ON.

b. Adjust the BFO PITCH control for comfortable pitch.

c. If signal interference is encountered, set the BANDWIDTH switch to the next lower position. For greatest degree of selectivity, set the BANDWIDTH switch to 2-, 1-, or .1-KC position and the AUDIO RESPONSE switch to SHARP. Set the BFO PITCH control at zero, tune the receiver for zero beat, and reset the BFO PITCH control for a comfortable pitch.

d. For manual gain control only, set the FUNCTION switch to MGC and control the sensitivity with the RF GAIN control.

e. When receiving machine code transmissions, set the FUNCTION switch to AGC and turn the AGC switch to SLOW.

f. To reduce the effects of fading, set the FUNCTION switch to AGC and turn the AGC switch to SLOW. For full sensitivity, rotate the RF GAIN control to position 10 (maximum clockwise).

g. Do not use SQUELCH when receiving mcw signals.

### 25. Reception of Frequency-Shift Signals

Correct operation of a radio receiving system designed for the reception of frequency-shift signals depends, to a great extent, on the experience of the operator and his ability to analyze the operating conditions at any given time. The settings of the controls then will depend on the operating conditions. Refer to the technical manual covering the receiving system for the exact operating procedure.

### 26. Frequency-Indicator Calibration

To maintain the tuning accuracy of the receiver, calibrate the frequency indicator at the point nearest the frequency desired for reception whenever the MEGACYCLE CHANGE control is operated to select another band. Calibration is accomplished by the use of the internal calibration oscillator as follows:

a. Set the BANDWIDTH switch to the .1-KC position.

b. Set the AUDIO RESPONSE switch to MED.

c. Set the RF GAIN control to 10.

d. Set the LOCAL GAIN control to 5.

e. Set the BFO switch to ON.

f. Turn the BFO PITCH to 0.

g. Turn the FUNCTION switch to CAL.

h. Adjust the MEGACYCLE CHANGE and KILOCYCLE CHANGE controls for a reading on the frequency indicator at the 100-kc point nearest the frequency desired for reception.

i. Turn the ZERO ADJ. control fully clockwise.

j. Rotate the ANT. TRIM to obtain indication on CARRIER LEVEL meter.

k. Adjust the KILOCYCLE CHANGE control for a zero beat indication in the headset or speaker.

l. Turn the ZERO ADJ. control counterclockwise to stop. The dial now is calibrated accurately.

## 27. Antijamming Instructions

When an operator recognizes that his receiver is being jammed, he promptly will inform his immediate superior officer. Under no conditions will he cease operating. To provide maximum intelligibility of jammed signals, he will adhere to the operational procedure indicated for each type of operation.

a. When receiving voice signals, and the receiver is being jammed, follow the procedure in the order indicated below until signal is heard with the least amount of interference.

(1) Rotate the KILOCYCLE CHANGE control very slowly through several dial markings on either side of the desired signal. Some separation of the desired signal from the jamming signal may be achieved.

(2) Set the BANDWIDTH switch to the 4- or 2-KC position; whichever gives the best results. Slowly tune as described in (1) above.

(3) Adjust the ANT. TRIM control to the point where the signal is heard with the least amount of interference.

(4) If the noise is severe, adjust the LIMITER control as required.

(5) When the jamming signal is weak, set the FUNCTION switch to MGC and

turn the RF GAIN control counterclockwise. The interfering signal might be reduced enough to permit part of the desired signal to come through.

(6) If these steps do not provide some degree of signal separation, request a change in frequency and call sign.

(7) Request the use of cw operation if this is permissible (b below).

(8) If practicable, change the direction, length, and height of the antenna. This practice may reduce the jamming effectiveness so that some degree of read-through is obtained.

(9) If the jamming action is such that communication is impossible, report this fact to the immediate superior. Keep the radio receiver tuned to the desired signal frequency; continue to operate.

b. When receiving cw or mcw signals, and the receiver is being jammed, follow the procedure in the order indicated below until read-through is established.

(1) Rotate the KILOCYCLE CHANGE control very slowly through a few dial markings on either side of the desired signal. Some separation of the desired signal from the jamming signal may be achieved.

(2) Set the BANDWIDTH switch to the 1- or .1-KC position and set the AUDIO RESPONSE switch to SHARP. Slowly tune as described in (1) above.

(3) Reset the BFO PITCH control; it may be possible to separate the pitch of the desired signal from the jamming signal to provide readability.

(4) Perform the steps indicated in a(3) through (6), (8), and (9) above.

c. When receiving frequency-shift signals, refer to the technical manual covering the receiving system for antijamming instructions.

## 28. Stopping Procedure

a. When the receiver is not to be used for a short interval but is to be maintained in a state of readiness, turn the FUNCTION switch to STAND BY.

*Note.* The FUNCTION switch should not be left too long in the STAND BY position.

b. Turn the FUNCTION switch to OFF.

## Section IV. OPERATION UNDER UNUSUAL CONDITIONS

### 29. General

The operation of Radio Receiver R-390/URR may be difficult in regions where extreme heat, cold, humidity and moisture, and sand conditions prevail. Procedures are given in paragraphs 30, 31, and 32 for minimizing the effects of these unusual operating conditions.

### 30. Operation in Arctic Climate

Subzero temperatures and climatic conditions associated with cold weather affect the efficient operation of the equipment. Instructions and precautions for operations under such adverse conditions follow:

- a. Handle the equipment carefully.
- b. Keep the equipment warm and dry.
- c. Place a knitted woolen cap over the earphones when operating in the open air with headsets that do not have rubber earpieces. Frequently, when headsets without rubber earpieces are worn, the edges of the ears may freeze without the operator being conscious of this condition. Never flex rubber earpieces, since this action may render them useless. If water gets into the receivers, or if water condenses within them, it may freeze and impede the action of the diaphragms. When this happens, unscrew the bakelite cap, and remove the ice and moisture.
- d. When equipment that has been exposed to the cold is brought into a warm room, it will start to sweat until it reaches room temperature. This condition also may arise when a room warms up after a cold night. When the equipment has reached room temperature, dry it thoroughly.

### 31. Operation in Tropical Climate

When operated in a tropical climate, radio equipment can be installed in tents, huts, or, when necessary, in underground shelters. When equipment is installed below ground level, and when it is set up in swampy areas, moisture conditions

are more acute than those normally met in the tropics. Ventilation usually is poor, and the high relative humidity causes condensation of moisture on the equipment whenever the temperature of the equipment becomes lower than the surrounding air. The receiver never should be inclosed to such an extent that adequate circulation of air is prevented.

### 32. Operation in Desert Climate

a. Although high temperatures and low humidity are characteristic of desert climate during the day, the drastic fall in temperature at night often causes condensation on the equipment. Dry the equipment thoroughly, as required.

b. The main problem which arises with equipment operation in desert areas is the large amount of sand, dust, or dirt which enters the moving parts of the equipment. The ideal preventive precaution is to house the equipment in a dustproof shelter. Since, however, such a building seldom is available and would require air conditioning, the next best precaution is to make the building in which the equipment is located as dustproof as possible with available materials. Hang wet sacking over the windows and doors, cover the inside walls with heavy paper, and secure the side walls of tents with sand, to prevent them from flapping in the wind.

c. Never tie power cords, signal cords, or other wiring connections to either the inside or outside of tents. Desert areas are subject to sudden wind squalls which may jerk the connections loose or break the lines.

d. Keep the equipment as free from dust as possible. Make frequent preventive maintenance checks (ch. 3). Pay particular attention to the lubrication of the equipment. Excessive amounts of dust, sand, or dirt that come into contact with oil and grease result in grit, which will damage the equipment.

## CHAPTER 3

### ORGANIZATIONAL MAINTENANCE

---

#### Section I. ORGANIZATIONAL TOOLS AND EQUIPMENT

#### 33. Tools, Materials, and Test Equipment Required

The following tools, materials, and test equipment are required for organizational maintenance procedures.

*a. Tools.*

Tool Equipment TE-41

*b. Materials.*

Cheesecloth, bleached, lint-free.

Paper, sand, flint No. 0000.

Solvent, Dry Cleaning (SD) (Fed. spec No. P-S-661a).

*c. Test Equipment.*

Electron Tube Test Set TV-7/U, TM 11-5083.

Multimeter TS-352/U, TM 11-5527.

#### 34. Special Tools Supplied With Radio Receiver R-390/URR

(fig. 22)

The special tools supplied with the receiver are mounted on the back panel, as shown in figure 22. The use of these tools is described in *a* through *d* below. Spare 20-ampere, 3-ampere, and  $\frac{3}{8}$ -ampere fuses are mounted on the rear panel of the receiver, under a protective cover.

*a. Tube Pullers.* Two cable grip type tube pullers are furnished: one for 7-pin miniature tubes and the other for 9-pin miniature tubes. To remove a tube, slide a tube puller of the proper size over the tube envelope. Pull upward on the tool and, at the same time, wobble the tube slightly. After the tube has been removed from the socket, remove the tube from the tool by pushing the tube toward the handle.

*b. Right-Angle Phillips Screwdriver.* The No. 8 right-angle screwdriver is used to remove the screws which secure the dust covers, front panel, removable subchassis and terminal strips.

*c. Fluted Socket Wrench.* The No. 8 fluted socket wrench is used to remove the front-panel bar knobs and the MEGACYCLE CHANGE and KILOCYCLE CHANGE knobs, and to loosen the collars which secure the camshafts and gears in the mechanical tuning system.

*d. Pin Straighteners.* The 7-pin and 9-pin straighteners are attached to the back panel. When a miniature tube is inserted into the receiver, either after maintenance or for replacement purposes, it first should be inserted into the proper pin straightener to align the pins properly.

#### Section II. PREVENTIVE MAINTENANCE SERVICES

#### 35. Definition of Preventive Maintenance

Preventive maintenance is work performed on equipment (usually when the equipment is not in use) to keep it in good working order so that breakdowns and needless interruptions in service will be kept to a minimum. Preventive maintenance differs from trouble shooting and repair since its object is the prevention of certain troubles rather than their correction (refer to AR 750-5).

#### 36. General Preventive Maintenance Techniques

*a.* Use No. 0000 sandpaper to remove corrosion.

*b.* Use a clean, dry, lint-free cloth or a dry brush for cleaning.

(1) If necessary, except for electrical contacts, moisten the cloth or brush with solvent (SD); then wipe the parts dry with a cloth.

(2) Clean electrical contacts with a small brush moistened with carbon tetrachloride; then wipe them dry with a clean cloth.

**Caution:** Repeated contact with carbon tetrachloride or prolonged breathing of the fumes is dangerous. See that adequate ventilation is provided.

*c.* If available, dry compressed air can be used at a line pressure not exceeding 60 pounds per square inch to remove dust from inaccessible

places; be careful, however, to avoid causing mechanical damage to delicate parts.

d. For further information on preventive maintenance techniques, refer to TB SIG 178.

### 37. Use of Preventive Maintenance Forms

a. The decision as to what items on DA Forms 11-238 and 11-239 are applicable to this equipment is a tactical decision to be made in the case of first echelon maintenance by the communication officer/chief or his designated representative and, in the case of second and third echelon maintenance, by the individual making the inspection. Instructions for the use of each form appear on the reverse side of the form.

b. Circled items in figures 23 and 24 are partially or wholly applicable to Radio Receiver R-390/URR. Paragraph references in the ITEM column indicate paragraphs in text which give additional or detailed information.

### 38. Performing Preventive Maintenance

**Caution:** Tighten screws, bolts, and nuts carefully. Fittings tightened beyond the pressure for which they are designed will be damaged or broken.

a. *Performing Exterior Preventive Maintenance.* Preventive maintenance is performed on the exterior of the equipment as follows:

- (1) Check the equipment against the table of components (par. 7), list of running spares (par. 12), and list of additional equipment required (par. 13), to see that components or parts are not missing. Observe the general condition of the equipment.
- (2) Use a clean, lint-free cloth to remove dust, dirt, and moisture from the headset, glass windows of the front-panel meters, front and back panels, and dust covers.
- (3) Inspect for proper seating of the antenna lead-in cable, headset and power-cord plugs, and fuses on the back panel. See that connections to the terminal boards on the back panel are secure.
- (4) Operate the controls to check for binding, scraping, excessive looseness, and positive action. Rough action or binding of the MEGACYCLE CHANGE and KILOCYCLE CHANGE controls indicates a damaged tuning system or the need for cleaning and lubrication.

- (5) Check for normal operation of the receiver (par. 46).
- (6) Clean and tighten the exterior of the case and POWER and REMOTE CONTROL connectors. Use a clean, lint-free cloth. Remove grease, if necessary, with a cloth dampened in solvent (SD); then wipe the parts dry.
- (7) Inspect the case and front and back panels for moisture and corrosion. Remove rust spots with No. 0000 sandpaper. Touch up the bare spots (par. 40).
- (8) Inspect the antenna lead-in cable, power cable, headset cord, and all other external cables for cuts, breaks, fraying, deterioration, kinks, and strain. Repair the cuts in the insulation by covering them with rubber tape held in place by electrician's tape. Replace or repair torn cables.
- (9) Inspect the antenna for bends, corrosion, loose fit, and cracked or broken insulators. If the antenna is bent, straighten it, if possible; if the antenna cannot be straightened, replace it. Tighten the antenna. Replace cracked or broken ceramic insulators.
- (10) Check for looseness of the front-panel control knobs. Tighten them with the fluted socket wrench provided.
- (11) Use a clean, damp cloth to clean the glass windows of the front-panel meters and frequency indicator; then wipe them dry. Clean the name plate.
- (12) Inspect the front-panel meters and the frequency indicator for cracked or broken glass windows.
- (13) If deficiencies noted are not corrected during inspection, indicate the action taken for correction.

b. *Performing Interior Preventive Maintenance.* To perform interior maintenance, proceed as follows:

**Caution:** Disconnect the power cable from the power source before performing the following operations. Upon completion, reconnect the power cable and check for satisfactory operation.

- (1) Remove the tubes from their sockets, one at a time, and inspect for loose envelopes and cracked sockets. Remove dust and dirt from the tube envelopes. Check the tubes for emission and short-circuited electrodes; use Electron Tube Test Set

**OPERATOR FIRST ECHELON MAINTENANCE CHECK LIST FOR SIGNAL CORPS EQUIPMENT**  
**RADIO COMMUNICATION, DIRECTION FINDING, CARRIER, RADAR**

*INSTRUCTIONS: See other side*

EQUIPMENT NOMENCLATURE

**RADIO RECEIVER R-390/URR**

EQUIPMENT SERIAL NO.

LEGEND FOR MARKING CONDITIONS: ✓ Satisfactory; X Adjustment, repair or replacement required; ⊗ Defect corrected.  
 NOTE: Strike out items not applicable.

**DAILY**

NO.	ITEM	CONDITION						
		S	M	T	W	T	F	S
①	COMPLETENESS AND GENERAL CONDITION OF EQUIPMENT (receiver, transmitter, carrying cases, wire and cable, microphones, tubes, spare parts, technical manuals and accessories). <b>PAR. 37a(1)</b>							
2	LOCATION AND INSTALLATION SUITABLE FOR NORMAL OPERATION.							
③	CLEAN DIRT AND MOISTURE FROM ANTENNA, MICROPHONE, HEADSETS, CHESTSETS, KEYS, JACKS, PLUGS, TELEPHONES, CARRYING BAGS. COMPONENT PANELS. <b>PAR. 37a(2)</b>							
④	INSPECT SEATING OF READILY ACCESSIBLE "PLUCK-OUT" ITEMS: TUBES, LAMPS, CRYSTALS, FUSES, CONNECTORS, VIBRATORS, PLUG-IN COILS AND RESISTORS. <b>PAR. 37a(3)</b>							
⑤	INSPECT CONTROLS FOR BINDING, SCRAPING, EXCESSIVE LOOSENESS, WORN OR CHIPPED GEARS, MISALIGNMENT, POSITIVE ACTION. <b>PAR. 37a(4)</b>							
⑥	CHECK FOR NORMAL OPERATION. <b>PAR. 37a(5)</b>							

**WEEKLY**

NO.	ITEM	CONDI- TION	NO.	ITEM	CONDI- TION
⑧	INSPECT CASES, MOUNTINGS, ANTENNAS, TOWERS, AND EXPOSED METAL SURFACES, FOR RUST, CORROSION, AND MOISTURE. <b>PAR. 37a(7)</b>		⑭	CLEAN AIR FILTERS, BRASS NAME PLATES, DIAL AND METER WINDOWS, JEWEL ASSEMBLIES. <b>PAR. 37a(11)</b>	
⑨	INSPECT CORD, CABLE, WIRE, AND SHOCK MOUNTS FOR CUTS, BREAKS, FRAYING, DETERIORATION, KINKS, AND STRAIN. <b>PAR. 37a(8)</b>		⑮	INSPECT METERS FOR DAMAGED GLASS AND CASES. <b>PAR. 37a(12)</b>	
⑩	INSPECT ANTENNA FOR ECCENTRICITIES, CORROSION, LOOSE FIT, DAMAGED INSULATORS AND REFLECTORS. <b>PAR. 37a(9)</b>		16	INSPECT SHELTERS AND COVERS FOR ADEQUACY OF WEATHER-PROOFING.	
11	INSPECT CANVAS ITEMS, LEATHER, AND CABLING FOR MILDEW, TEARS, AND FRAYING.		17	CHECK ANTENNA GUY WIRES FOR LOOSENESS AND PROPER TENSION.	
⑫	INSPECT FOR LOOSENESS OF ACCESSIBLE ITEMS: SWITCHES, KNOBS, JACKS, CONNECTORS, ELECTRICAL TRANSFORMERS, POWER-STATS, RELAYS, SELSYNS, MOTORS, BLOWERS, CAPACITORS, GENERATORS, AND PILOT LIGHT ASSEMBLIES. <b>PAR. 37a(10)</b>		18	CHECK TERMINAL BOX COVERS FOR CRACKS, LEAKS, DAMAGED GASKETS, DIRT AND GREASE.	
⑬	IF DEFICIENCIES NOTED ARE NOT CORRECTED DURING INSPECTION, INDICATE ACTION TAKEN FOR CORRECTION. <b>PAR. 37a(13)</b>				

**DA FORM 11-238**  
1 MAY 51

REPLACES DA AGO FORM 419, 1 DEC 50, WHICH IS OBSOLETE.

TM 856-21

Figure 23. DA Form 11-238.



**SECOND AND THIRD ECHELON MAINTENANCE CHECK LIST FOR SIGNAL CORPS EQUIPMENT**  
**RADIO COMMUNICATION, DIRECTION FINDING, CARRIER, RADAR**

*INSTRUCTIONS: See other side*

EQUIPMENT NOMENCLATURE

EQUIPMENT SERIAL NO.

**RADIO RECEIVER R-390/URR**

**LEGEND FOR MARKING CONDITIONS:** ✓ Satisfactory; ✕ Adjustment, repair or replacement required; (1) Defect corrected;  
 NOTE: Strike out items not applicable.

NO.	ITEM	COND. CL.	NO.	ITEM	COND. CL.
(1)	COMPLETENESS AND GENERAL CONDITION OF EQUIPMENT (receiver, transmitter, carrying cases, wire and cable, microphones, tubes, spare parts, technical manuals and accessories). PAR. 37 a (1)		(19)	ELECTRON TUBES - INSPECT FOR LOOSE ENVELOPES, CAP CONNECTORS, CRACKED SOCKETS; INSUFFICIENT SOCKET SPRING TENSION; CLEAN DUST AND DIRT CAREFULLY; CHECK EMISSION OF RECEIVER TYPE TUBES. PAR. 37 b (1)	
2	LOCATION AND INSTALLATION SUITABLE FOR NORMAL OPERATION.		20	INSPECT FILM CUT-OUTS FOR LOOSE PARTS, DIRT, MISALIGNMENT AND CORROSION.	
(2)	CLEAN DIRT AND MOISTURE FROM ANTENNA, MICROPHONE, HEADSETS, CHESTSETS, KEYS, JACKS, PLUGS, TELEPHONES, CARRYING BAGS, COMPONENT PANELS. PAR. 37 a (2)		(21)	INSPECT FIXED CAPACITORS FOR LEAKS, BULGES, AND DISCOLORATION. PAR. 37 b (2)	
(3)	INSPECT SEATING OF READILY ACCESSIBLE "PLUCK-OUT" ITEMS: TUBES, LAMPS, CRYSTALS, FUSES, CONNECTORS, VIBRATORS, PLUG-IN COILS AND RESISTORS. PAR. 37 a (3)		(22)	INSPECT RELAY AND CIRCUIT BREAKER ASSEMBLIES FOR LOOSE MOUNTINGS; BURNED, PITTED, CORRODED CONTACTS; MISALIGNMENT OF CONTACTS AND SPRINGS; INSUFFICIENT SPRING TENSION; BINDING OF PLUNGERS AND HINGE PARTS. PAR. 37 b (3)	
(4)	INSPECT CONTROLS FOR BINDING, SCRAPING, EXCESSIVE LOOSENESS, WORK OR CHIPPED GEARS, MISALIGNMENT, POSITIVE ACTION. PAR. 37 a (4)		23	INSPECT VARIABLE CAPACITORS FOR DIRT, MOISTURE, MISALIGNMENT OF PLATES, AND LOOSE MOUNTINGS.	
(5)	CHECK FOR NORMAL OPERATION. PAR. 37 a (5)		(24)	INSPECT RESISTORS, BUSHINGS, AND INSULATORS, FOR CRACKS, CHIPPING, BLISTERING, DISCOLORATION AND MOISTURE. PAR. 37 b (4)	
(6)	CLEAN AND TIGHTEN EXTERIOR OF COMPONENTS AND CASES, RACK MOUNTS, SHOCK MOUNTS, ANTENNA MOUNTS, COAXIAL TRANSMISSION LINES, WAVE GUIDES, AND CABLE CONNECTIONS. PAR. 37 a (6)		(25)	INSPECT TERMINALS OF LARGE FIXED CAPACITORS AND RESISTORS FOR CORROSION, DIRT AND LOOSE CONTACTS. PAR. 37 b (5)	
(7)	INSPECT CASES, MOUNTINGS, ANTENNAS, TOWERS, AND EXPOSED METAL SURFACES, FOR RUST, CORROSION, AND MOISTURE. PAR. 37 a (7)		(26)	CLEAN AND TIGHTEN SWITCHES, TERMINAL BLOCKS, BLOWERS, RELAY CASES, AND INTERIORS OF CHASSIS AND CABINETS NOT READILY ACCESSIBLE. PAR. 37 b (6)	
(8)	INSPECT CORD, CABLE, WIRE, AND SHOCK MOUNTS FOR CUTS, BREAKS, FRAYING, DETERIORATION, KINKS, AND STRAIN. PAR. 37 a (8)		(27)	INSPECT TERMINAL BLOCKS FOR LOOSE CONNECTIONS, CRACKS AND BREAKS. PAR. 37 b (7)	
(9)	INSPECT ANTENNA FOR ECCENTRICITIES, CORROSION, LOOSE FIT, DAMAGED INSULATORS AND REFLECTORS. PAR. 37 a (9)		28	CHECK SETTINGS OF ADJUSTABLE RELAYS.	
11	INSPECT CANVAS ITEMS, LEATHER, AND CABLING FOR MILDEW, TEARS, AND FRAYING.		29	LUBRICATE EQUIPMENT IN ACCORDANCE WITH APPLICABLE DEPARTMENT OF THE ARMY LUBRICATION ORDER.	
(12)	INSPECT FOR LOOSENESS OF ACCESSIBLE ITEMS: SWITCHES, KNOBS, JACKS, CONNECTORS, ELECTRICAL TRANSFORMERS, POWERSTATS, RELAYS, SELSYNS, MOTORS, BLOWERS, CAPACITORS, GENERATORS, AND PILOT LIGHT ASSEMBLIES. PAR. 37 a (10)		30	INSPECT GENERATORS, AMPLIDYNES, DYNAMOTORS, FOR BRUSH WEAR, SPRING TENSION, ARCING, AND FITTING OF COMMUTATOR.	
13	INSPECT STORAGE BATTERIES FOR DIRT, LOOSE TERMINALS, ELECTROLYTE LEVEL AND SPECIFIC GRAVITY, AND DAMAGED CASES.		(31)	CLEAN AND TIGHTEN CONNECTIONS AND MOUNTINGS FOR TRANSFORMERS, CHOKES, POTENTIOMETERS, AND RHEOSTATS. PAR. 37 b (8)	
(14)	CLEAN AIR FILTERS, BRASS NAME PLATES, DIAL AND METER WINDOWS, JEWEL ASSEMBLIES. PAR. 37 a (11)		(32)	INSPECT TRANSFORMERS, CHOKES, POTENTIOMETERS, AND RHEOSTATS FOR OVERHEATING AND OIL-LEAKAGE. PAR. 37 b (9)	
(15)	INSPECT METERS FOR DAMAGED GLASS AND CASES. PAR. 37 a (12)		33	BEFORE SHIPPING OR STORING - REMOVE BATTERIES.	
16	INSPECT SHELTERS AND COVERS FOR ADEQUACY OF WEATHERPROOFING.		34	INSPECT CATHODE RAY TUBES FOR BURNT SCREEN SPOTS.	
17	CHECK ANTENNA GUY WIRES FOR LOOSENESS AND PROPER TENSION.		35	INSPECT BATTERIES FOR SHORTS AND DEAD CELLS.	
18	CHECK TERMINAL BOX COVERS FOR CRACKS, LEAKS, DAMAGED GASKETS, DIRT AND GREASE.		36	INSPECT FOR LEAKING WATERPROOF GASKETS, WORN OR LOOSE PARTS.	
			(37)	MOISTURE AND FUNGIPROOF. PAR. 37 b (10)	
(38)	IF DEFICIENCIES NOTED ARE NOT CORRECTED DURING INSPECTION, INDICATE ACTION TAKEN FOR CORRECTION. PAR. 37 a (13)				

DA FORM 11-239  
 1 MAY 51

REPLACES DA AGO FORM 419, 1 DEC 50, WHICH IS OBSOLETE.

05-10-64332-1

TM 856-22

Figure 24. DA Form 11-239.

TV-7/U. Straighten the tube pins with the pin straighteners on the back panel. Replace the tubes carefully; check for adequate spring tension in the individual pin sockets. See that the tubes are seated firmly in the sockets in an upright position and that the tube shields are replaced correctly. See that corrugated metal inserts are replaced in the vfo tube shield and that the shield is tightened down so that movement is not possible.

- (2) Inspect fixed capacitors C101 and C103 on the main frame (fig. 81), and C546 and C547 on 455-kc if. subchassis (fig. 68), for leaks, bulges, and discoloration.
- (3) Inspect antenna relay K101 (fig. 80) for a loose mounting; burned, pitted, or corroded contacts; misalignment of contacts and springs; and insufficient spring tensions.

- (4) Inspect resistors for cracks, chipping, blistering, discoloration, and moisture.
- (5) Inspect terminals of large fixed capacitors and resistors for corrosion, dirt, and loose contacts.
- (6) Clean and tighten the connectors in the receiver.
- (7) Inspect terminal strips for loose connections, cracks, and breaks.
- (8) Clean and tighten connections and mountings for transformers, chokes, potentiometers, and rheostats.
- (9) Inspect Transformer T801 (fig. 78) of Power Supply PP-621/URR for overheating and leakage. Inspection should be made soon after shutting down the receiver.
- (10) Check the condition of moistureproof and fungiproof material in the receiver (par. 39b).

### Section III. LUBRICATION AND WEATHERPROOFING

#### 39. Lubrication and Weatherproofing

*a. General.* Signal Corps equipment, when operated under severe climatic conditions such as prevail in tropical, arctic, and desert regions, requires special treatment and maintenance. Fungus growth, insects, dust, corrosion, salt spray, excessive moisture, and extreme temperatures are harmful to most materials.

*b. Tropical Maintenance.* A special moistureproofing and fungiproofing treatment has been devised which, if properly applied, provides a reasonable degree of protection. This treatment is explained in TB SIG 13 and TB SIG 72.

*c. Winter Maintenance.* Special precautions necessary to prevent poor performance or total operational failure of equipment in extremely low temperatures are explained in TB SIG 66 and TB SIG 219.

*d. Desert Maintenance.* Special precautions necessary to prevent equipment failure in areas subject to extremely high temperatures, low hu-

midity, and excessive sand and dust are explained in TB SIG 75.

*e. Lubrication.* No lubrication is to be performed on Radio Receiver R-390/URR at organizational level. Lubrication instructions are contained in paragraph 106.

#### 40. Rustproofing and Painting

*a.* When the finish on the front panel or case has been badly scarred or damaged, touch up bare surfaces. Use solvent (SD) to remove dirt and grease.

**Caution:** Do not use steel wool. Minute particles frequently enter the case and cause harmful internal shorting or grounding of circuits.

*b.* When a touchup job is necessary, remove loose paint from the case and front panel, and apply paint with a small brush. Paint (Specification MIL-E-11857) used will be No. 2610 semi-gloss gray enamel (Federal Specification TT-C-595). When a front-panel marking has been erased, use a fine brush and white enamel to replace the marking.

### Section IV. TROUBLESHOOTING AT ORGANIZATIONAL MAINTENANCE LEVEL

#### 41. General

*a.* The troubleshooting and repairs that can be performed at organizational maintenance level

(operators and repairmen) are necessarily limited in scope by the tools, test equipment, and replaceable parts issued, and by the existing tactical sit-

uation. Accordingly, troubleshooting is based on the performance of the equipment and the use of the senses in determining such troubles as burned-out tubes and overheated transformers.

*b.* The purpose of the paragraphs that follow in this section is to assist the operator in determining which of the subchassis of the receiver is at fault and in localizing the fault in that assembly to the defective stage or part, such as a tube or fuse. Repair will be limited to the replacement of those parts included in the running spares.

## 42. Visual Inspection

*a.* Failure of the equipment to operate properly may be caused by one or more of the following faults:

- (1) Improperly connected, worn, or broken power cable (par. 44).
- (2) Improperly connected, worn, or broken speaker or headset cord.
- (3) Burned-out fuse (fig. 22).
- (4) Grounded or broken antenna or antenna lead-in.
- (5) Improperly connected antenna lead-in.
- (6) Defective tube (par. 43 and figs. 25 and 26).
- (7) Improperly connected or seated external or internal interconnecting cables.
- (8) Loose connection on terminal strips on back panel (fig. 22).

*b.* When the receiver fails to operate and the cause is not immediately apparent, check as many of the above items as is practicable before starting a detailed examination. If possible, obtain information from the operator of the receiver regarding performance at the time the trouble occurred.

*c.* When visually inspecting the tubes for burned-out filaments, it may be discovered that more than one tube is not lighted. This condition can be caused by one filament burning out in a circuit having several filaments in series. All filaments, except the four connected directly across the 25.2-volt filament supply, are connected in series circuits which include two, three, or four filaments. In a series circuit, an open filament in one stage will cause another stage to appear defective. Tubes V605, V606, V801, and V802, oven heaters HR401, HR701, and HR901, and indicating lamps I 101 and I 102 are connected directly across the 25.2-volt filament supply. Cold-cathode, gas-filled tubes V608 and V609, also

known as glow-discharge voltage regulators, do not require heated filaments. Figures 25 and 26 show the locations of all tubes in Radio Receiver R-390/URR. As an aid in locating trouble caused by an open filament circuit, the reference designations of the tubes in each filament circuit are listed below.

---

### Series filament circuits (fig. 54)

---

V202, V203, V204, and V205  
V401, V402, and V201  
V501, V502, V503, and V504  
V505, V506, and V511  
V507 and V510  
RT512, V508, and V701  
V601 and V602  
V603, V604, V607, and V509  
V901 and V902

---

## 43. Tube-Testing Techniques

*a. General.* When Electron Tube Test Set TV-7/U, or equal, is available, test the tubes (according to the instructions supplied with the tester) for shorts, leakage, and either emission or mutual conductance. If a tube tester is not available, a similar receiver in good operating condition can be used to test the tubes by the substitution method described in *b* below. If another receiver is not available, the tubes can be checked by substituting spares, as described in *c* below. Observe the following precautions when removing and replacing tubes:

- (1) Test each tube and replace it in its socket before removing another tube. However, if it is necessary to remove more than one tube for testing, mark each one so that it can be replaced, if satisfactory, in the proper socket.
- (2) Remove the tube shields by pressing down and turning one-fourth turn counterclockwise. The vfo tube shield is held in place by a special clamp. See that the corrugated metal insert is in place when replacing the vfo tube shield.
- (3) Use the proper tube puller (fig. 22), and extract the tubes carefully. Avoid excessive movement of the tube from side to side during extraction, as miniature tube pins are bent easily.
- (4) Straighten the pins with the pin straighteners on the rear panel of the receiver; then replace the tubes in the receiver.

- (5) Do not discard tubes that were replaced with new tubes when using the tube substitution method. These tubes should be checked on a tube checker; if good, they may be used in less critical circuits.

*b. Checking Tubes by Substitution in a Similar Receiver.* Tune a similar receiver, which is in good operating condition, to a voice signal that is not subject to fading; a signal on one of the lower-frequency bands is preferred. Turn the FUNCTION switch to AGC and the RF GAIN control to the position marked 10. Make the substitutions from the faulty receiver to a corresponding position in the good receiver, one tube at a time; tap the tube under test, and, if noise or abnormal change in volume is observed, replace the tube. A considerable decrease in indication on the CARRIER LEVEL meter, or a noticeable decrease in volume or quality of the signal emitted from the speaker or headset, indicates a weak or otherwise defective tube. However, different test results for the following tubes must be observed.

- (1) When tube V509 or V510 (agc circuit) is weak, a decreased indication on the CARRIER LEVEL meter with an increase in volume may be noted. A weak V511 (agc time constant circuit) will cause an increase in indication on the CARRIER LEVEL meter without any change in volume. A weak section of V511 (if cathode follower) will produce a weak signal at IF OUTPUT 50 OHM connector J106. To test tubes V507 and V510 (noise limiters), tune the receiver away from the test signal and, if noise is received, rotate the LIMITER control clockwise; the tubes under test and tubes that are known to be good should be equally effective in reducing noise. After testing these tubes, return the LIMITER control to OFF, and retune the receiver to the test signal. To test V508, turn the BFO switch to ON and, while turning the BFO PITCH control through its entire range, listen for the beat note.
- (2) Check tubes V801 and V802 of the ac power supply to see that all four heaters glow with equal brightness; a blue flash indicates an arcing tube. V605, V606, and V607 of the audio-frequency sub-

chassis and V701 of the vfo subchassis are checked by listening to the audio output and observing the indication on the CARRIER LEVEL meter. Visually inspect V608 and V609; if they do not glow properly, they will cause abnormal B+ voltage. When testing tubes V901 and V902, turn the FUNCTION switch to CAL, tune through several 100-kc points, and observe the indication on the CARRIER LEVEL meter.

- (3) Tubes in the af circuits are tested by listening to the volume and quality of the output signal of the af channels. When testing tubes V601, V602, and V603 (local af amplifier), listen to the output signal of the local audio channel. When testing V601, also test the squelch circuit by tuning between stations to see if it is operating properly, that is, eliminating all interchannel noise and static. When testing tubes V602 (line af amplifier) and V604, listen to the output signal from the balanced-line circuit and observe the indication on the LINE LEVEL meter. Generally, small changes in LINE LEVEL meter indication may be expected because of the differences among tubes.

*c. Checking Tubes by Substituting Spares.* Replace the tubes in the faulty receiver, one at a time, with the respective spare tubes, following the same general procedure outlined in *b* (1), (2), and (3) above.

#### **44. Checking Power Cable Assembly CX-1358/U**

A defective power cord is often the cause of an inoperative receiver. The repairman often can save time by checking this cable first. Remove the connector from the ac input and, with the cable assembly still attached to POWER receptacle J104, connect an ohmmeter, such as that included in Multimeter TS-352/U, across the terminals of the ac connector. Turn the FUNCTION switch to OFF; the ohmmeter should indicate infinity. With the FUNCTION switch set to STAND BY, the ohmmeter indication should be about 1.5 ohms for 115-volt ac input and 3.5 ohms for 230-volt ac input. If these conditions are not obtained, remove the cable assem-

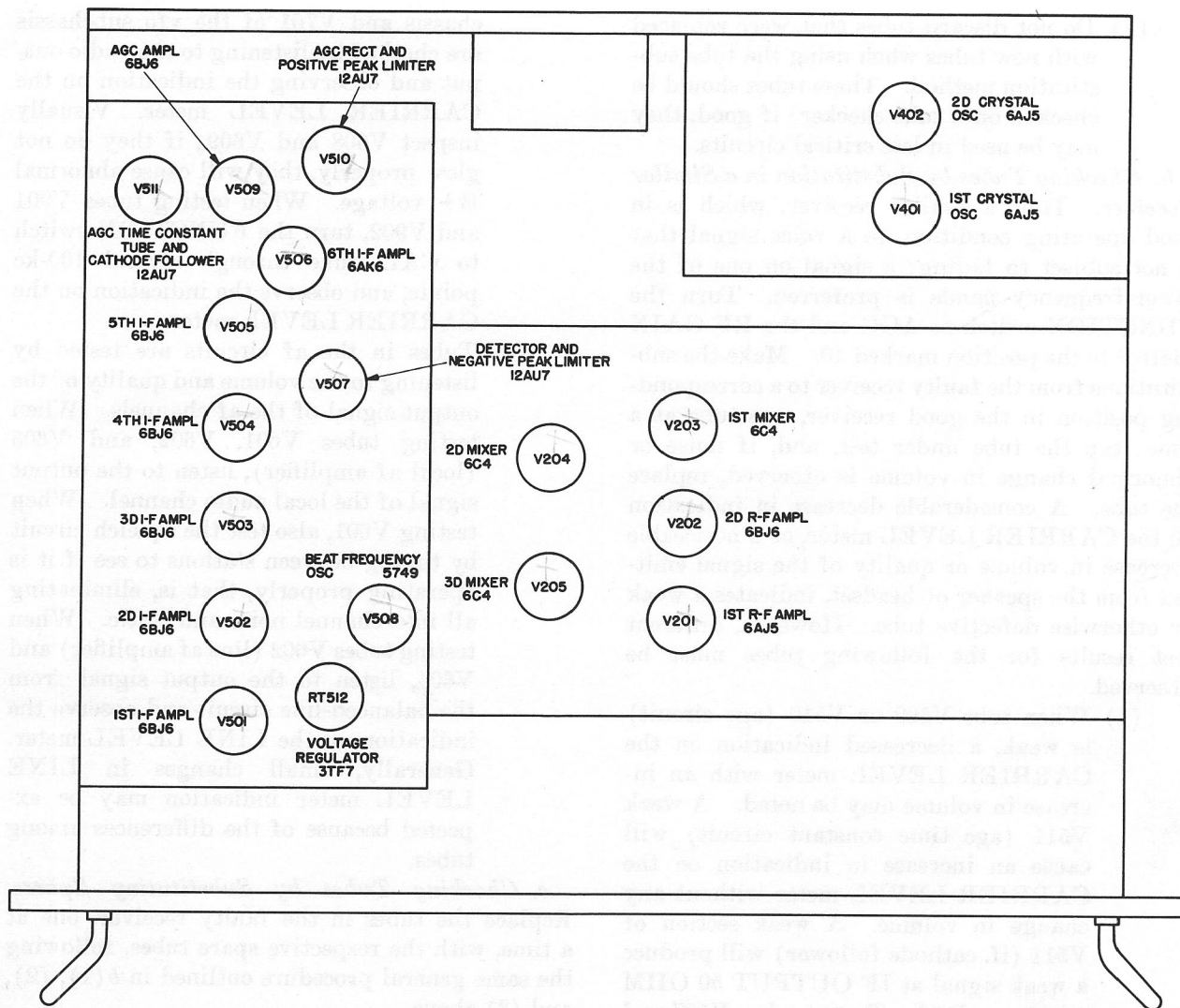

Figure 25. Radio Receiver R-390/URR, top deck, tube location.

TM 856-23

bly from the receiver receptacle. Check for a short circuit in the cord by measuring between the two terminals of the ac connector and for a break or an open circuit by measuring between the associated terminals of the two connectors. If these tests show that the cable assembly is good, the fault is in the receiver.

#### 45. Subchassis Testing

Make the simple tests outlined in *a*, *b*, and *c* below to determine in which subchassis the trouble lies. When an abnormal indication in these tests is obtained, further checking of the tubes, connectors, and fuses of the suspected subchassis often will disclose the source of the trouble.

**Warning:** To prevent electrical shock or harmful short circuits, turn off the receiver before removing the plugs or touching any circuits other than those specified below.

*a. Power Supply and Af Subchassis.* Set the FUNCTION switch at MGC and the AUDIO RESPONSE switch at MED. Rotate the RF GAIN, LOCAL GAIN, and LINE GAIN controls to their extreme clockwise positions. Remove tubes V507 and V510 and, with a pointed metallic probe with an insulated handle, touch tube-socket pin 1 of V510. A loud click in the speaker or headset indicates that the power supply and af subchassis are functioning. Replace the tubes after the test. If the af subchassis and

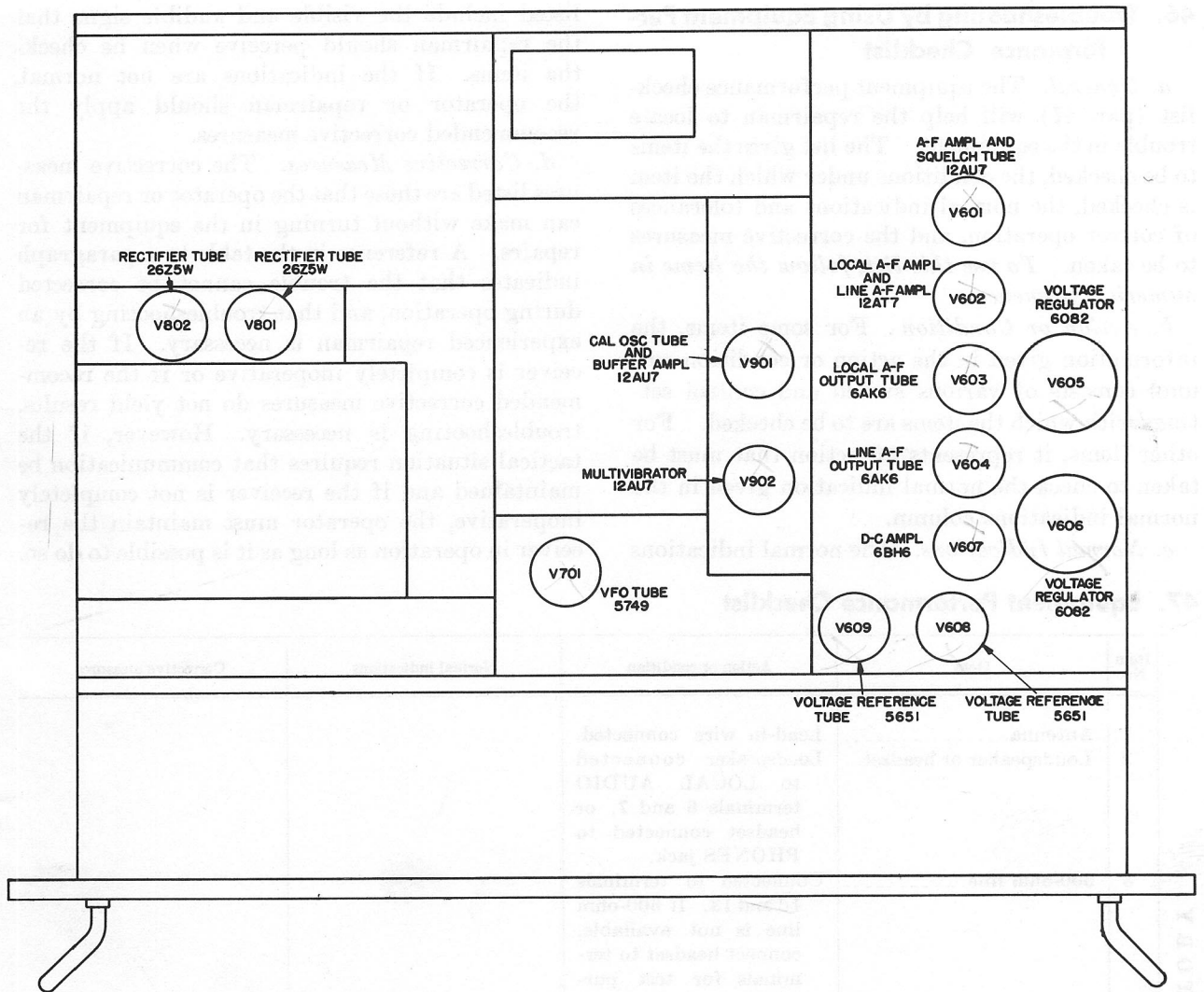

Figure 26. Radio Receiver R-390/URR, bottom deck, tube location.

TM856-24

power supply are functioning, proceed with the test described in *b* below; if these units are not functioning, check the following:

- (1) Fuses F101 and F102 (AC 3A and B+ 3/8A) (fig. 22).
- (2) Power cable connection (par. 44).
- (3) Speaker or headset.
- (4) Tubes V801 and V802 (fig. 26).
- (5) Tubes V601 through V606 (fig. 26).
- (6) Cable connectors on af subchassis (fig. 74).

*b. If. Subchassis.* Remove plug P226 (fig. 86) from receptacle J526 and touch the contact of the receptacle with the probe. A loud click from the speaker or headset indicates that the af and if. circuits are functioning. Replace the plug. If

the if. subchassis is functioning, proceed with the testing of the rf subchassis (*c* below). If the subchassis is not functioning, check the following:

- (1) Tube V510 (fig. 25).
- (2) Tubes V501 through V507 (fig. 25).
- (3) Connector J517 on the if. subchassis (fig. 68).

*c. Rf Subchassis.* The connection of the antenna to the antenna receptacle while the receiver is turned on should produce a loud clicking sound in the speaker or headset. When a sound is not produced, check tubes V201 through V205. An additional test can be made by turning the FUNCTION control to CAL and tuning to calibration signals.

## 46. Troubleshooting by Using Equipment Performance Checklist

*a. General.* The equipment performance checklist (par. 47) will help the repairman to locate trouble in the equipment. The list gives the items to be checked, the conditions under which the item is checked, the normal indications and tolerances of correct operation, and the corrective measures to be taken. *To use this list, follow the items in numerical sequence.*

*b. Action or Condition.* For some items, the information given in the action or condition column consists of various switch and control settings with which the items are to be checked. For other items, it represents an action that must be taken to check the normal indication given in the normal indications column.

*c. Normal Indications.* The normal indications

listed include the visible and audible signs that the repairman should perceive when he checks the items. If the indications are not normal, the operator or repairman should apply the recommended corrective measures.

*d. Corrective Measures.* The corrective measures listed are those that the operator or repairman can make without turning in the equipment for repairs. A reference in the table to a paragraph indicates that the trouble cannot be corrected during operation, and that troubleshooting by an experienced repairman is necessary. If the receiver is completely inoperative or if the recommended corrective measures do not yield results, troubleshooting is necessary. However, if the tactical situation requires that communication be maintained and if the receiver is not completely inoperative, the operator must maintain the receiver in operation as long as it is possible to do so.

## 47. Equipment Performance Checklist

PREPARATORY	Item No.	Item	Action or condition	Normal indications	Corrective measures
	1	Antenna .....	Lead-in wire connected.		
	2	Loudspeaker or headset..	Loudspeaker connected to LOCAL AUDIO terminals 6 and 7, or headset connected to PHONES jack.		
	3	600-ohm line .....	Connected to terminals 10 and 13. If 600-ohm line is not available, connect headset to terminals for test purposes.		
	4	Power cable .....	Connected between receiver and power source.		
	5	AUDIO RESPONSE switch.	Set at MED.		
	6	BANDWIDTH switch..	Set at 4 or 8 KC.		
	7	RF GAIN .....	Set at 10.		
	8	LOCAL GAIN control..	Set at 5.		
	9	Terminal strips .....	The following pairs of terminals on the rear terminal strips are connected together: 1 and 2, 3 and 4, 11 and 12, and 14 and 15. External ground is connected to terminal 16 as a safety precaution.		

	Item No.	Item	Action or condition	Normal indications	Corrective measures
START	10	FUNCTION switch.....	Turn to AGC.....	Dial lamps light.....  Rushing noise or signal is heard in speaker or headset.	Check fuse (AC 3A) (fig. 22). Check power cable (par. 44). Check dial lamps. Refer to paragraph 93. Refer to paragraphs 45 and 92.
	11	MEGACYCLE CHANGE control.	Set to each band, in turn..	Normal signal output on each band.	Rotate control several times to clean switch contacts. Refer to paragraphs 92 and 93.
EQUIPMENT PERFORMANCE	12	KILOCYCLE CHANGE control.	Tune across a band.....	Signals received. CARRIER LEVEL meter indicates strength of signal.	Refer to paragraphs 92 and 93.
	13	ANT. TRIM.....	Rotate control.....	Obtain peak indication on CARRIER LEVEL meter for each band.	Refer to paragraphs 83 and 94.
	14	LOCAL GAIN control..	Rotate control in either direction.	Volume at loudspeaker or headset increases or decreases.	Refer to paragraphs 95 and 96.
	15	LINE GAIN control....	Rotate control.....	Output level to 600-ohm line or headset and LINE LEVEL meter increases or decreases.	If headset level varies and pointer of meter is sticking, tap meter lightly. If local output is satisfactory but line output is weak, check tubes V602 and V604. Refer to paragraphs 95 and 97.
	16	RF GAIN control.....	Rotate control.....	Audio output and CARRIER LEVEL meter indication increases or decreases.	Refer to paragraphs 92 and 93.
	17	FUNCTION switch.....	Turn to MGC.....  Turn to AGC, and tune through several different signals. Turn to CAL, and then operate the KILOCYCLE CHANGE control.  Turn FUNCTION to SQUELCH, and then operate the KILOCYCLE CHANGE control.  Return FUNCTION switch to AGC and RF GAIN to 10, at completion of this check.	With no signal input, noise level should increase and CARRIER LEVEL does not indicate. Output volume nearly constant.  Deflection on CARRIER LEVEL meter at each 100-kc reading.  No reception of noise while tuning between stations.	Refer to paragraphs 92 and 93.  Refer to paragraphs 83 and 94.  Reset ANT. TRIM control. Check tubes V901 and V902. Refer to paragraphs 92 and 93.  If noise is high, turn the RF GAIN control counterclockwise until the squelch circuit is effective enough to reduce the noise. Check tube V601.



## EQUIPMENT PERFORMANCE

Item No.	Item	Action or condition	Normal indications	Corrective measures
18	LIMITER control.....	Turn clockwise.....	Noise peaks are reduced in amplitude.	Refer to paragraphs 83 and 94.
19	BREAK IN relay switch..	Turn to ON. Short BRK IN terminal 9 on rear panel to ground momentarily.	LINE LEVEL meter is disabled and break-in relay functions to silence receiver. Line audio output circuits from receiver REMOTE CONTROL receptacle are disconnected from receiver output.	Refer to paragraphs 83 and 94.
20	LINE METER switch....	Turn to +10..... Turn to 0..... Turn to -10..... Turn to OFF.....	Line level is 10 vu above LINE METER indication. LINE METER indicates the line level controlled by the LINE GAIN control. Line level is 10 vu below LINE METER indication. LINE LEVEL meter is disconnected. Line audio output is still connected.	Refer to paragraphs 92 and 97.
21	BFO OFF-ON control and BFO PITCH control.	Turn the BFO control to ON. Tune in a cw signal, and vary the BFO PITCH control.	Tone of signal varies.....	Refer to paragraph 93.
22	BANDWIDTH switch....	Turn from 16 to 0.1 KC..	Selectivity becomes sharper. Only low-frequency audio tones are heard in the counterclockwise positions.	Refer to paragraph 99.
23	AUDIO RESPONSE switch.	Operate through three positions.	Permits amplification of nearly full of range in WIDE position, middle and low frequencies in MED. position, and 800 cps in SHARP position.	Refer to paragraphs 83 and 94.
STOP	24	OVENS OFF-ON switch..	Turn to OFF.....	Oscillator ovens are turned off.
	25	FUNCTION switch.....	Turn to STAND BY..... Turn to OFF.....	Receiver is silent. Filament circuits and oscillator circuits are kept on for immediate reception. Turns off all receiver circuits.

## CHAPTER 4

### THEORY

#### Section I. THEORY OF RADIO RECEIVER R-390/URR

#### 48. General

*a.* Radio Receiver R-390/URR provides for the reception of voice, c-w, and frequency-shift signals over a frequency range of .5 to 32 mc. The receiver is basically a superheterodyne of the multiple conversion type. Triple conversion is used for the lower frequencies (.5 to 8 mc) and double conversion for the higher frequencies (8 to 32 mc).

*b.* The receiver operates from a self-contained power supply designed to operate at a nominal input of 115 or 230 volts over a frequency range of 48 to 62 cycles per second (cps).

*c.* The tuning system of Radio Receiver R-390/URR provides linear tuning over the entire frequency range of the receiver. Permeability tuning (insertion of powdered-iron cores into coils) and a system of gears and cams make possible linear tuning and the use of a counter-type indicator on the front panel to show the frequency selected.

*d.* Radio Receiver R-390/URR employs unitized construction consisting of seven subchassis which are mounted onto a main frame. Certain components of unrelated electrical circuits sometimes are located on the same subchassis. The circuit analysis given in the following paragraphs is based upon the signal path established in the block diagram (fig. 27) and the overall schematic diagram (fig. 107). However, in performing troubleshooting procedures and repairs, the technician must remember that the physical location of a component often is quite removed from the circuit in which it is effective. For example, although the voltage regulator is effectively a part of the power supply, it is actually located on the af subchassis, to utilize space efficiently. To determine on which subchassis a particular component is located, refer to figure 107.

#### 49. Block Diagram (fig. 27)

*a.* The block diagram shows the signal path from the antenna to the output. A schematic dia-

gram (fig. 108) shows details of the circuits in the same order. A schematic diagram of each subchassis and the interconnecting wiring is shown in figure 107.

*b.* Power Supply PP-621/URR provides direct current (dc) for the antenna and break-in relays, ac to the filament and oven circuits, and B+ voltage to the voltage-regulator circuit. All B+ voltages supplied to the receiver are regulated. The voltage-regulator circuit consists of series regulator V605 and V606, dc amplifier V607, and voltage-reference tubes V608 and V609. The power supply has a transformer, with two primary windings connected in series for 230-volt ac operation (or connected in parallel) for 115-volt ac operation and rectifiers V801 and V802. Dc voltage for the break-in relay circuits is provided by dry-disk rectifier CR801.

*c.* Rf signals are fed to the receiver from either a balanced or unbalanced antenna. Antenna relay K101 grounds the antenna input for break-in operation and during calibration. This relay also operates to protect the antenna circuits of the receiver during standby operation. If the balanced antenna input is used, the rf signals pass through one of several antenna transformers (selection of which is determined by the operating frequency of the receiver) and are fed to first rf amplifier V201. If the unbalanced antenna input is used, the signals are capacitor-coupled to secondary of the antenna transformers and are applied to first rf amplifier V201.

*d.* The calibration oscillator (V901 and V902) supplies a signal at every 100-kc point within the frequency range of the receiver. A 1,000-kc crystal-oscillator stage, one-half of V901, provides a signal for synchronizing multivibrator stage V902 at 100 kc. A buffer-amplifier stage, one-half of V901, isolates the multivibrator from the loading effects of the rf circuit and increases the strength of the higher 100-kc harmonics. When the FUNCTION switch is in the CAL position,

B+ voltage is fed to the calibration oscillator circuits.

e. The output of first rf amplifier V201 is coupled to the grid of second rf amplifier V202. The gain of the first and second rf amplifiers is controlled manually by the RF GAIN control and automatically by the agc voltage. These stages amplify the rf signals before applying them to the mixer circuits. The output of the second rf amplifier (.5 to 32 mc) is fed to either the first or second mixer, depending on the MEGACYCLE CHANGE control setting. For frequencies from .5 to 8 mc, the rf signal is mixed with the output of first crystal oscillator V401 in first mixer stage V203 to produce an if. signal which is variable in frequency from 9 to 18 mc. For frequencies from 8 to 32 mc, the rf signal is fed directly from the output of the second rf stage to second mixer V204. The heterodyning signal for this mixer is supplied from second crystal oscillator V402. The if. range of the second-mixer-output signal is 3 to 2 mc. It should be noted that the intermediate frequency at the output of the second mixer decreases as the input signal frequency increases. The input to third mixer V205 always has a frequency range of 3 to 2 mc except in the .5- to 1-mc band, in which case it has a frequency range of 2.5 to 2 mc. The output of 455 kc. The frequency range of the vfo is from in the third mixer to produce a fixed frequency of 455 kc. The frequency range of the vfo is from 3.455 to 2.455 mc on all ranges of the receiver except the .5- to 1-mc range, in which case the upper frequency limit is 2.955 mc.

f. The 455-kc output signal of the third mixer is applied to the grid of first if. amplifier V501 either directly or through crystal filter Z501, depending on the bandwidth desired. For the two narrow pass bands, .1 and 1 kc, the crystal filter is used. Four additional degrees of selectivity which do not use the crystal filter are accomplished in the if. stages by the BANDWIDTH switch which varies the coupling between the primary and secondary circuits of the if. transformers. The if. amplifier consists of six stages, V501 through V506, which, together with the associated transformers, provide the required pass band. The output of fifth if. amplifier V505 is divided to supply a 455-kc signal to each of three stages: sixth if. amplifier V506, agc amplifier V509, and the cathode follower, one-half of V511. The output signal of the sixth if. amplifier is demodulated

in the detector circuit, one-half of V507. An external diode load may be connected from DIODE LOAD terminal 14 and ground with the jumper between terminals 14 and 15 removed. The output of the fifth if. amplifier is amplified in agc amplifier V509, and the resulting signal is rectified by the agc rectifier, one-half of V510. When the FUNCTION switch is set for AGC operation, the gain of rf amplifiers V201 and V202 and of if. amplifiers V501 and V505 is controlled automatically by a dc voltage developed by the agc rectifier, one-half of V510, to keep the output level of the receiver relatively constant and independent of signal-strength variation at the antenna. Thus for strong signals, the grid bias is high and the gain of the controlled stages is reduced and for weak signals the grid bias is reduced and gain of the controlled stages is increased. The response rate of the agc circuits can be controlled to satisfy reception requirements through the use of the AGC switch, the agc time constant circuit, and one-half of tube V511. For MGC operation, the agc bus is grounded by the FUNCTION switch. The cathode follower, one-half of V511, provides a low-impedance connection (50 ohms) from the output of the fifth if. stage for use when the receiver is employed for frequency-shift teletypewriter and single-sideband reception. To facilitate operation in the reception of radiotelegraph signals, in certain system applications and in calibration, bfo tube V508 provides a signal in the frequency range of 452 to 458 kc. This signal is mixed with the 455-kc if. output signal of the sixth if. amplifier to produce a beat frequency in the output of the detector which is in the af range. The output of the detector (one-half of V507) is coupled to the af amplifier (one-half of V601) through a negative peak limiter (one-half of V507) and a positive peak limiter (one-half of V510) which prevents noise peaks from exceeding average signal level. If operation without limiting is desired, the limiters can be disabled by a front-panel control.

g. In addition to supplying signals to the limiter, the detector, one-half of V507, supplies a dc signal to the squelch tube, one-half of V601, which is a voltage amplifier. The average dc output voltage of the squelch tube varies in proportion to the average signal level. When the signal level drops below some predetermined noise level established by the setting of the RF GAIN control and when the FUNCTION switch is set for SQUELCH op-

eration, this voltage operates squelch relay K601, which short-circuits the output of af amplifier V601 to quiet the receiver output. The output of the af amplifier also can be shorted to ground by break-in relay K602, when the FUNCTION switch is set to STANDBY, or to either MGC, AGC, or SQUELCH when the BREAK IN switch is set to ON and an external circuit provides a ground. The output from the af amplifier (one-half of V601) is divided and applied through separate gain controls to a local af amplifier (one-

half of V602) and a line af amplifier (one-half of V602). The output of the local af amplifier supplies signals to local af output tube V603, which has connections for a speaker or a headset and for side tone signals from an associated transmitter to permit monitoring. The line af amplifier supplies signals to line af output tube V604, which has connections for a balanced line.

Figure 27. Radio Receiver R-390/URR, block diagram.

(Contained in separate envelope)

## Section II. CIRCUIT ANALYSIS

### 50. Antenna Circuit

(fig. 28)

The antenna circuit provides means for matching antennas that have different characteristics to the input of first rf amplifier V201.

a. Antennas that have a nominal, balanced, terminal impedance of 50 to 200 ohms and terminate in two wires (such as twin lead or dual-conductor coaxial cable) are connected through J108 to the primary winding of one of six antenna transformers. One lead connects through J110, P210, and S202, and the other lead connects through J111, P211, and S201. Six transformers (T201 through T206) are employed to cover the frequency range of .5 to 32 megacycles. The transformer in use for a given band is selected by the operation of S201, S202, S203, S204 and S205. Since the theory of operation is identical for all bands, only one band is shown in the stage schematic diagram (fig. 28). The conditions shown are for the .5- to 1-mc band. This means of simplification will be followed in the discussion of all succeeding stages unless otherwise indicated. Primary winding of T201 is balanced to ground by fixed capacitor C202 and section A of variable capacitor C201. The 125-ohm input impedance of T201 is essentially resistive, but the reactive component depends critically upon the adjustment of the ANT. TRIM capacitor C225, in parallel with C203. By suitable adjustment, the reactive component may be made less than 20 ohms over the entire frequency range of the transformer. However, at higher frequencies it may be considerably greater. The primary and secondary windings of T201 are magnetically coupled and electrostatically shielded. Transformer T201 contains a powdered-iron core which is movable for purposes of achieving resonance for any desired signal

within the range of .5 to 1 mc. Movement of this tuning core in conjunction with other tuning cores throughout the equipment (par. 80) is effected by rotating the KILOCYCLE CHANGE control. The voltage developed across the secondary of T201 is applied, through switch S205 (rear) and coupling capacitor C227, to the control grid (pin 1) of first rf amplifier V201. When an unbalanced antenna such as a whip is used, connection is provided from J107 through J109 and P209, and through switch S204, capacitor C204, switch S205 (rear), and coupling capacitor C227, to the control grid of V201. When this type antenna is used, it is connected to the secondary winding of T201. The B section of capacitor C201 is provided for alignment purposes. Switch S203 connects either section A or B or both of C225 in parallel with fixed capacitor C203.

b. In addition to its basic function as part of the antenna transformer, the secondary winding of T201 along with R201 provides a dc path for biasing the grid of the first rf amplifier. To prevent reactive effects between the transformer in use and the transformer next lower in frequency range, the latter is short-circuited by S205 (front). In the case shown, there is no lower frequency range, therefore, the secondary winding of T203 is shorted instead. Antenna relay K101 is operated through the break-in relay circuit, and it grounds both antenna-input circuits when an associated transmitter is in operation, during calibration, and during standby operation. Resistor R126 prevents the gradual accumulation of a static electrical charge on the antenna, and, if an unusually strong charge is induced (such as might be caused by transmission from an adjacent transmitter) glow tube I 103 becomes momentarily conductive and passes the charge to ground.

c. Switches S201 through S205 are sections of a six-position band switch which is operated by the MEGACYCLE CHANGE control. When the band switch is rotated to a new position, the following events occur simultaneously.

- (1) One of the six antenna transformers is inserted into the input circuit (depending on the operating frequency selected).
- (2) Both, or either, of the two sections ANT. TRIM capacitor C225 are added to the antenna circuit, as required.
- (3) One of the unused transformer secondary windings is short-circuited.

d. The antenna circuit is designed to cover a range of .5 to 32 mc in six bands, as follows: .5 to 1 mc, 1 to 2 mc, 2 to 4 mc, 4 to 8 mc, 8 to 16 mc, and 16 to 32 mc. The transformer used for each band is T201 through T206, respectively.

Figure 28. Antenna circuit and first rf amplifier, schematic diagram.

(Contained in separate envelope)

## 51. First Rf Amplifier V201

(fig. 28)

The first rf amplifier uses a miniature pentode tube, type 6AJ5, to increase the amplitude of the signals from the antenna before they are applied to the second rf stage. The following discussion will be concerned only with the .5- to 1-mc band.

a. Grid bias for the first rf amplifier is supplied by cathode resistor R203 and RF GAIN control R123, and from the age circuit through FUNCTION switch S107 (when set to AGC), decoupling resistor R202 (which is bypassed by C226), the secondary winding of T201, the contacts of S205 (rear), and grid resistor R201 (which is bypassed by C227). R201 drops most of the grid bias developed by V201 when strong off-tune signals are present and prevents this bias voltage from backing up into the age line and blocking off the receiver. When the FUNCTION switch is rotated to the MGC position, the age line is grounded and tube bias is controlled completely by RF GAIN control R123 and cathode resistor R203. To prevent degeneration in the first rf stage, a low-impedance signal circuit from cathode to ground is provided by capacitor C229. Since RF GAIN potentiometer R123 also controls the gain of second rf amplifier V202 (through R209) and of first and fifth if. amplifiers V501 and V505 (through P117-16 and J517-16), decoupling is

necessary. This is accomplished by C231, which provides a low-reactance path to ground at radio and intermediate frequencies and acts as a noise filter when the RF GAIN control is operated. An external gain control may be connected between terminals 1 and 7 (GND) of TB102 (fig. 22), provided the jumper between terminals 1 and 2 is removed. The screen grid (pin 6) potential is obtained through voltage-dropping resistor R205 from the output of the 180-volt supply through L246, J214-A, and P114-A, and FUNCTION switch S107 (front). To prevent variations in screen-grid voltage caused by screen-current changes, rf signal voltages that appear on the screen are bypassed to ground through capacitor C230. Rf choke L246 and bypass capacitor C339 function as a low-pass inductance-capacitance filter to prevent rf signals from entering the common B+ circuits. Plate voltage is applied to V201 through voltage dropping resistor R206, tank coil of Z201, and band switch S206, and the power supply is decoupled from the plate circuit of the tube by capacitor C250. A very small value of capacitance, C341, is added to the interelectrode capacitance between the plate of V201 and ground so that its value equals that of V202. This is done to provide tracking in the 16 to 32 mc range. Voltage for the plate and screen circuits is applied through FUNCTION switch S107 (front) in all positions except STAND BY and OFF.

b. Signals from the antenna circuit are applied, through coupling capacitor C227, to the control grid (pin 1) of the first rf amplifier. The amplified signals appearing at the plate (pin 5) of the first rf amplifier are applied to tuned circuit Z201. The output of the first rf stage is not taken from across the entire resonant circuit but is connected to the junction point of C233 and C333, two series capacitors which serve as a voltage divider across the coil. This circuit arrangement provides a high Q (since it reduces loading) and an increased stability (since it limits gain) and minimizes any detuning that the gain control might cause as a result of tube capacitance variation in the following stage. In addition, tracking at the higher frequency ranges is facilitated by the fact that the tube and circuit-wiring capacitance is across only a portion of the resonant circuit. The output signals of the first rf amplifier are applied, through band switch S207 and coupling capacitor C251, to the grid circuit of the second rf amplifier. The tank coil of Z 201 is permeability-tuned for reso-

nance by the operation of the KILOCYCLE CHANGE controls and C232 is provided for alinement.

c. In addition to the normal rf signals, a calibration signal (par. 76) can be applied to the grid circuit of V201 through J924, P224, and coupling capacitor C228. Pin E206 (fig. 62) provides an easily accessible connection to the grid circuit for test purposes.

d. Switches S206 and S207 are sections of the six-position band switch mentioned previously (par. 50), and are controlled by the MEGACYCLE CHANGE control. Selection of one of the six tuned circuits in the output circuit of the first rf amplifier is made with this control. The frequency range of each tuned circuit is as follows: Z201, .5 to 1 mc; Z202, 1 to 2 mc; Z203, 2 to 4 mc; Z204, 4 to 8 mc; Z205, 8 to 16 mc; Z206, 16 to 32 mc. The core in each tuned circuit is movable and is controlled by the KILOCYCLE CHANGE and the MEGACYCLE CHANGE controls through the differential except for the .5- to 1-mc and the 1- to 2-mc bands when it is controlled by the KILOCYCLE CHANGE control only.

## 52. Second Rf Amplifier V202

(fig. 29)

The second rf amplifier uses a miniature pentode tube, type 6BJ6, which amplifies the signal voltages from the first rf amplifier.

a. The grid return to the age circuit is through parasitic suppressor R221, grid bias resistor R207 and resistor R208. Resistor R208 and capacitor C252 form a decoupling network. The cathode (pin 2) and suppressor grid (pin 7) are connected together and return to ground through cathode resistor R209 and RF GAIN control R123. C253 is the cathode bypass capacitor. Provision for external RF GAIN control is at terminals 1 and 2 of TB102 which normally are connected together by a jumper. The RF GAIN control is common to the first and second rf stages and the first and fifth if. stages. Connection to the latter is made through P117-16 and J517-16. R203 isolates the first rf stage from the circuit. The screen grid (pin 6) is bypassed for rf by C254 and is connected to the junction of R210 and R211 which form a voltage divider across the 180-volt supply. The plate (pin 5) circuit is completed to B+ through S208, tank coil of Z207, and decoupling resistor R212 which is bypassed by C278. Additional filtering of the supply voltage is accomplished by

L246 and C339 which also prevent rf signal voltages from entering the power supply circuits.

b. The signal is applied through band switch S207, coupling capacitor C251, and parasitic suppressor R221, to the control grid (pin 1) of second rf amplifier V202. The amplified signal appearing at the plate is applied, through S208, to tuned circuit Z207. As described for the first rf amplifier plate circuit, capacitors C256 and C335 are connected in series as a voltage-divider circuit. To achieve greater selectivity than is obtainable from one tuned circuit, the junction of these capacitors is coupled, through capacitor C274, to the grid of the first mixer and to another tuned circuit, Z213, which is identical to Z207 and contains a voltage divider, made up of capacitors C277 and C337. The values of the capacitors have been selected so that only one-tenth of the output voltage is applied to the control grid (pin 6) of the first mixer, V203; since this is equivalent to connecting the grid of V203 to a tap nine-tenths of the way down on coils of Z207 and Z213 grid loading and detuning are reduced (because tube input capacitance is made negligible by the use of a large tuning capacitance in the grid circuit), and thus high selectivity is obtained. Tuned circuits Z207 and Z213 are individually shielded, to prevent coupling between tank coils; a separate slug for each circuit is mounted on the .5- to 1-mc tuning rack. Trimmer capacitors C255 and C276, and test point E207 (fig. 62) connected to the grid of V202, are provided for repair and alignment purposes.

c. In addition to tuned circuits Z207 and Z213, which cover the .5- to 1-mc range, five pairs of inductors cover the additional ranges: Z208 and Z214, 1 to 2 mc; Z209 and Z215, 2 to 4 mc; Z210 and Z216, 4 to 8 mc; Z211 and Z217, 8 to 16 mc; and Z212 and Z218, 16 to 32 mc. Triple conversion is used in the frequency range of .5 to 8 mc, and double conversion is used in the frequency range of 8 to 32 mc. Therefore, in the frequency range of .5 to 8 mc, the output from the second rf amplifier is fed through switch S209 to the grid circuit of first mixer V203, and in the frequency range of 8 to 32 mc, the output is fed through switch S210 to the grid circuit of second mixer V204. The resonant circuits are tuned by varying the degree of insertion of powdered-iron cores.

Figure 29. Second rf amplifier, schematic diagram.

(Contained in separate envelope)

### 53. First Mixer V203

(fig. 30)

The first mixer stage uses a miniature triode, type 6C4. On frequency ranges from .5 to 8 mc, the signals from the output of the second rf amplifier are applied to the control grid (pin 6). The output of the first crystal oscillator V401 is applied to the cathode (pin 7), and the two signals are heterodyned in the mixer stage to produce a signal of 9 to 18 mc in the plate circuit. The frequency of this signal is variable and is the sum of the frequencies of the two input signals (par. 103).

a. Grid bias for V203 is developed across R213, and R214 is a parasitic suppressor. The cathode circuit, composed of the secondary of transformer T401 and resistor R404 in series to ground, provides cathode bias. Bypass capacitor C404 prevents degeneration across R404. B+ to the plate of the first mixer is fed through tank coil of Z219, decoupling resistor R215 (which is bypassed for rf by C304), L246, J214-A, and P114-A. Capacitor C305 provides fixed tuning. L246 and C339 serve as an rf filter, as described in the analysis of the second rf amplifier stage (par. 52a). C306 is for alinement purposes.

b. The first mixer functions only over the .5- to 8-mc range; therefore, throughout this range of frequencies, the signal voltage from the second rf amplifier stage is applied through S209 to the control grid of the first mixer. The injection signal from the first crystal oscillator is a fixed frequency for each frequency range and is applied through T401, J421, and P221, to the cathode (pin 7) of V203. T401 serves to isolate the mixer from the oscillator, and to match the low-impedance cathode circuit of the mixer to the comparatively high output impedance of the oscillator plate circuit. The plate circuit is tuned over the 9- to 18-mc range by changing the positions of the powdered-iron cores in Z219, Z220, and Z221. Capacitors C306, C309, and C311 are provided for purposes of alinement. The 9- to 18-mc signal from the plate of the mixer is fed, through C307, C310, and S210, to the grid circuit of second mixer V204. Tuned circuits Z220 and Z221 are added to provide additional selectivity. C308 is for fixed tuning and provides equivalent capacitance to that of the coaxial cable across Z219 and Z221. The rear section of S210 connects the output of first mixer V203 to second mixer V204 for the .5- to

8-mc range (four bands), and connects the output of second rf amplifier V202 to the second mixer for the 8- to 32-mc range (two bands). In the 8- to 32-mc range, the front section of S210 grounds the output circuit of V203.

c. The powdered-iron cores which tune the tank coils of circuits Z219, Z220, and Z221, move simultaneously to a predetermined position when the MEGACYCLE CHANGE knob is turned. In addition, the three tuned circuits are mounted on a movable platform, the position of which is controlled by the KILOCYCLE CHANGE knob (par. 80). E208 (fig. 62) is provided for test and alinement purposes.

Figure 30. First mixer stage, schematic diagram.

(Contained in separate envelope)

### 54. First Crystal Oscillator V401

(fig. 31)

The first crystal oscillator provides the injection signal to first mixer stage V203 on the eight lower frequency bands. For simplicity, the circuitry for operation on only the first band, .5 to 1 mc, is shown in figure 31. The oscillator uses a type 6AJ5 miniature pentode, connected in an electron-coupled Colpitts-type circuit where a highly selective crystal is substituted for the resonant circuit.

a. Bias is developed by crystal current through resistor R401. Since no crystals are in the circuit after the first eight bands, protective bias must be provided to prevent damage to V401 on the remaining higher frequency bands. Resistor R402 provides the required negative bias for the control grid (pin 1) because of the positive potential on the cathode (pin 2). The grid is returned to ground through R401. Voltage for the screen grid and the plate is applied through common choke L406 and resistor R403. Resistor R409 is a voltage dropping resistor for the screen grid (pin 6) and C438 is the screen rf bypass capacitor. The B+ voltage to the plate is fed through the primary winding of T401. Both the plate and screen circuits are decoupled from the power supply by R403 and C403.

b. The oscillator is a triode consisting of the cathode (pin 2), the control grid (pin 1), and the screen grid (pin 6). The screen grid acts as the oscillator anode. The control grid is connected to crystal Y401 through the contact marked 0 of switch S402. Capacitor C438 returns the signal to the oscillator tank through ground. Crystal

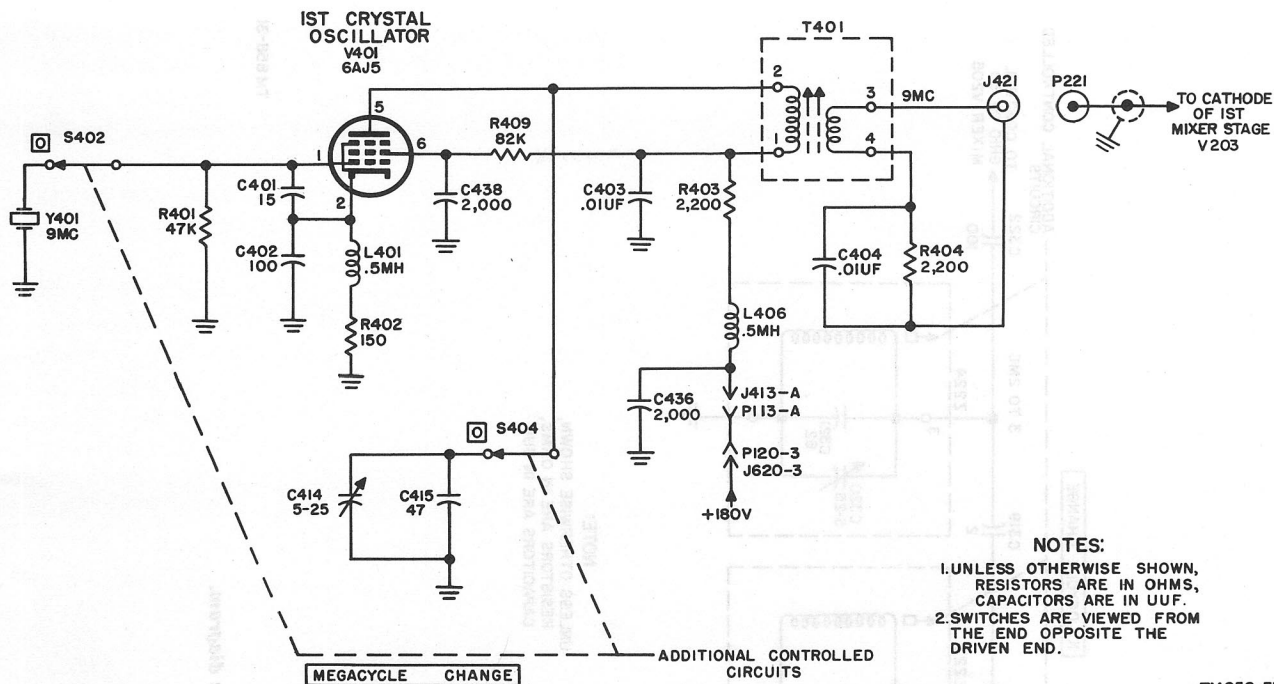

TM856-33

Figure 31. First crystal oscillator, schematic diagram.

Y401 and capacitors C401 and C402 form the oscillator tank circuit; the proportion of the feedback voltage supplied to the control grid is determined by the voltage divider action across the two capacitors. The amount of feedback is sufficient to maintain oscillation at the fundamental crystal frequency of 9 mc. Rf choke L401, by offering a high-impedance path to the rf signal, isolates the bias resistor, R402, from the crystal circuit, and thus prevents unnecessary loading, which might stop oscillation. Since the output of the oscillator is coupled into the plate circuit because of the electron flow within the tube, variations in plate loading have little effect on oscillator stability. Capacitors C414 and C415, in parallel, are connected by switch S404 to the primary winding of T401 for adjustment to obtain the maximum output at the resonant crystal frequency of 9 mc. The 9-mc signal is magnetically coupled to the secondary winding of T401 and is applied through jack J421 and plug P221 to the cathode of first mixer tube V203. Bias resistor R404 and bypass capacitor C404 are a part of the cathode circuit of V204.

c. Only five crystals and five trimmer capacitors are used to cover the frequency range of .5 to 8 megacycles in eight steps (fig. 103 part 1). The chart below shows the crystal symbol, its fundamental frequency, the trimmer section in use, and

the step of switches S402 and S404. The step corresponds to the reading of the two left-hand digits of the frequency indicator on the front panel.

Crystal symbol	Fundamental frequency in use	Trimmer section	S402 step
Y401	9	C414 and C415.....	0 and 6.
Y402	8	C414 and C416.....	1 and 5.
Y403	10	C414.....	2 and 7.
Y404	12.6	C414 and C417.....	3.
Y405	7	C414 and C418.....	4.

Note. C414 is made up of five variable capacitors.

### 55. Second Mixer V204 (fig. 32)

The second mixer stage uses a miniature triode, type 6C4. On the eight lower-frequency bands, signals from first mixer tube V203 (or from the output of the second rf amplifier on the 8- to 36-mc range) are applied to the control grid (pin 6) of the mixer. The output of second crystal oscillator V402 is applied to the cathode (pin 7). The two signals heterodyne in the stage to produce a signal of 2.5 to 2 mc in the plate circuit when the receiver is set to the .5- to 1-mc band, and 3 to 2 mc on all other bands. The frequencies



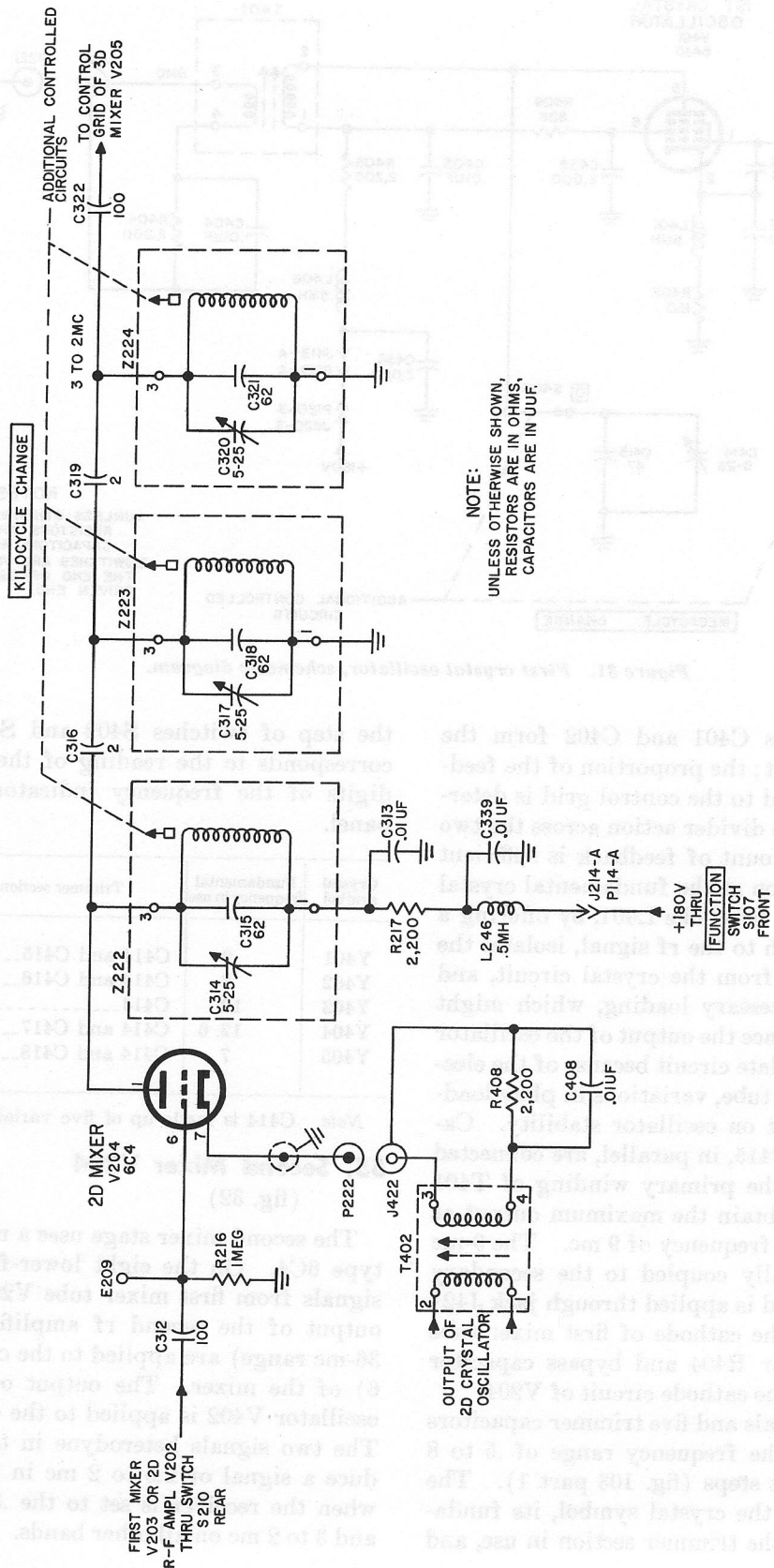

Figure 92. Second mixer stage, schematic diagram.

in the plate circuit are variable, and are the difference between the signal frequency applied to the grid and the oscillator frequency injected at the cathode (par. 103).

a. Grid bias is developed across R216, and cathode bias is developed across resistor R408 which is bypassed for rf by capacitor C408. B+ voltage is applied to the plate through P114-A, J214-A, L246, R217, and tank coil of Z222. Decoupling from the power supply is provided by resistor R217 and capacitor C313. L246 and C339 serve as an rf filter, as described in paragraph 51.

b. Unlike the first mixer, the second mixer functions for all bands. Signals are selected from the first mixer or the second rf stage by switch S210 (rear) (fig. 30) and are applied through capacitor C312 to the control grid (pin 6) of V204. The injection signal from the second crystal oscillator is applied to the mixer cathode (pin 7) through T402, which serves to isolate the mixer from the oscillator and to match the low-impedance cathode circuit of the mixer to the comparatively high output impedance of the oscillator plate circuit. The signal from the mixer plate is applied through coupling capacitors C316, C319, and C322 to the grid of third mixer V205.

c. Since the output frequency of the plate circuit is variable over a range of 3 to 2 mc (par. 49e), it is necessary to tune the circuit to resonance. This is achieved by positioning powdered-iron cores in coils Z222, Z223, and Z224. Test pin E209 (fig. 62) in the grid circuit and capacitor C314 in parallel with C315, C317 in parallel with C318, and C320 in parallel with C321 in the tuned circuits, are provided for repair and alignment purposes.

## 56. Second Crystal Oscillator V402

(fig. 33)

The second crystal oscillator provides injection signal to second mixer V204 on all 32 frequency bands. For simplicity, the circuitry of the first band, .5 to 1 mc, is shown in figure 33. This oscillator uses a type 6AJ5 miniature pentode in a Colpitts circuit employing crystals as the frequency determining element of the grid circuit.

a. Bias is developed by crystal current flowing through R405 in the grid (pin 1) circuit. Additional bias is developed by cathode resistor R406 in the cathode (pin 2) circuit. R410 is the screen

grid (pin 6) voltage dropping resistor and C409 is the screen grid rf bypass capacitor. B+ voltage is fed to the plate through the primary of T402. Both the screen and plate circuits are decoupled from the power supply by R407 and C407. Additional filtering is provided by L406 and C436.

b. The oscillator is a triode consisting of the cathode (pin 2), the control grid (pin 1) and the screen grid (pin 6). The screen grid acts as the plate for the oscillator and is at ground potential for the signal voltage. The portion of the signal voltage, which is fed from the screen grid (or plate) to the control grid to maintain oscillation at the fundamental crystal frequency (12 mc) is determined by the voltage divider action of series-connected capacitors C405 and C406. To produce sustained oscillations, the values of these two capacitors are selected so that the feedback is not at the electrical center of the tuned circuit. L402, an rf choke in the cathode circuit, offers a high impedance path to the rf signal which isolates bias resistor R406 and prevents unnecessary loading of the crystal circuit. Electron coupling of the rf signal into the plate circuit eliminates the effects on the stability by variations in the plate load. Capacitors C420 and C419 are placed in the primary circuit of T402 by switch S403 to permit adjustment for maximum output at the resonant crystal frequency of 12 mc. The signal is coupled through T402 to the cathode circuit of second mixer tube V204 through jack J422.

c. In response to the operation of the MEGA-CYCLE CHANGE control, switch section S401, at the position marked O, connects crystal Y406, cut to 12-mc frequency, to the control grid (pin 1) at the same time that switch section S403 connects capacitors C419 and one section C420 into the plate (pin 5) circuit for alignment purposes. To facilitate the use of a fewer number of crystals and to avoid the use of fragile crystals required to cover the higher frequency ranges, the fundamental frequencies of 18 crystals, or their harmonics are used. Crystals are selected by switch section S401. S403 selects the trimmer section of C420 used with each crystal.

- (1) The chart below shows the crystal symbol, its fundamental frequency, and the step or position of S401. The step corresponds to the reading of the two left-hand digits of the frequency indicator on the front panel.

Crystal symbol	Fundamental freq in mc	S401 step
Y406	12	0, 1, 9, and 21.
Y407	15	2 and 12.
Y408	6.2	3.
Y409	14	4, 11, and 25.
Y410	8	5 and 13.
Y411	9	6, 15, and 24.
Y412	10	7, 17, and 27.
Y413	11	8, 19, and 30.
Y414	13	10 and 23.
Y415	8.5	14.
Y416	11.333	31.
Y417	10.666	29.
Y418	10.333	28.
Y419	9.666	26.
Y420	12.5	22.
Y421	11.5	20.
Y422	10.5	18.
Y423	9.5	16.

(2) The following chart shows the step or position of S403 and the trimmer section which is used to resonate the plate inductance.

S403 step	Trimmer section
0, 1, and 9	C420 and C419.
2 and 12	C420 and C421.
3 (thru C433), 6, and 15	C420 and C422.
4 and 11	C420 and C423.
5 and 13	C420 and C424.
7 and 17	C420 and C425.
8	C420 and C426.
10	C420 and C427.
14	C420 and C428.
16	C420 and C429.
18	C420 and C430.
19	C420 and C431.
20	C420 and C432.
21	C420.
22	C420.
23	C420.
24	C420.
25	C420.
26	C420.
27	C420.
28	C420.
29	C420.
30	C420.
31	C420.

d. The 24 trimmers contained within C420 are adjustable for the required output frequencies. The adjustments are described in the alignment

procedure given in chapter 5. As indicated in paragraph 103, 10 bands operate directly at the fundamental frequency, 13 at the second harmonic, and 9 at the third harmonic of the corresponding crystals. To obtain frequency tripling on the fourth band, series capacitor C433 is used to decrease the total capacitance introduced into the tuned primary of T402. In addition to decreasing the number of crystals required, frequency doubling and tripling eliminate the need for the extremely delicate crystals for the higher frequencies.

### 57. Third Mixer V205

(fig. 34)

The third mixer stage uses a miniature triode, type 6C4. Signals from second mixer V204 and variable frequency oscillator V701 are heterodyned in this stage to produce an intermediate or difference frequency of 455 kc for application to the first if. amplifier grid circuit.

a. Bias voltage for the grid of this stage is developed across grid resistor R218. Cathode bias is developed across resistor R219 and the combined resistances of the secondary components of Z702. L704 is wound on R705. The combined resistance of the parallel group is less than .1 ohm and provides the dc return for the cathode. B+ voltage is applied to the plate (pin 1) through P114-A, J214-A, L246, R220, and through primary winding L240 of T207. Resistor R220 and capacitor C325 form a plate circuit decoupling network. L246 and C339 serve as an rf filter, as described in the analysis of the second rf amplifier (par. 51).

b. The output signal (3 to 2 mc) of the second mixer stage V204 is applied to the grid of the third mixer through coupling capacitor C322. The vfo signal 3.455 to 2.455 mc is applied, from tuned circuit Z702 (composed of T701 and an impedance matching network made up of R704, C708, L703, R705, L704, and C709), to the cathode of V205 through P723, J223, and coupling capacitor C323. The rf plate circuit of the third mixer consists of resonant circuit T207 (composed of fixed tuning capacitor C324, primary winding L240, and secondary winding L241). Transformer T207 has a broad pass band at 455 kc. A screwdriver-adjusted powdered-iron core is provided for alignment purposes. The secondary winding of L241 is center-tapped. The center tap is connected to the shields of a pair of coaxial cables, the center conductors of which are connected to the ends of



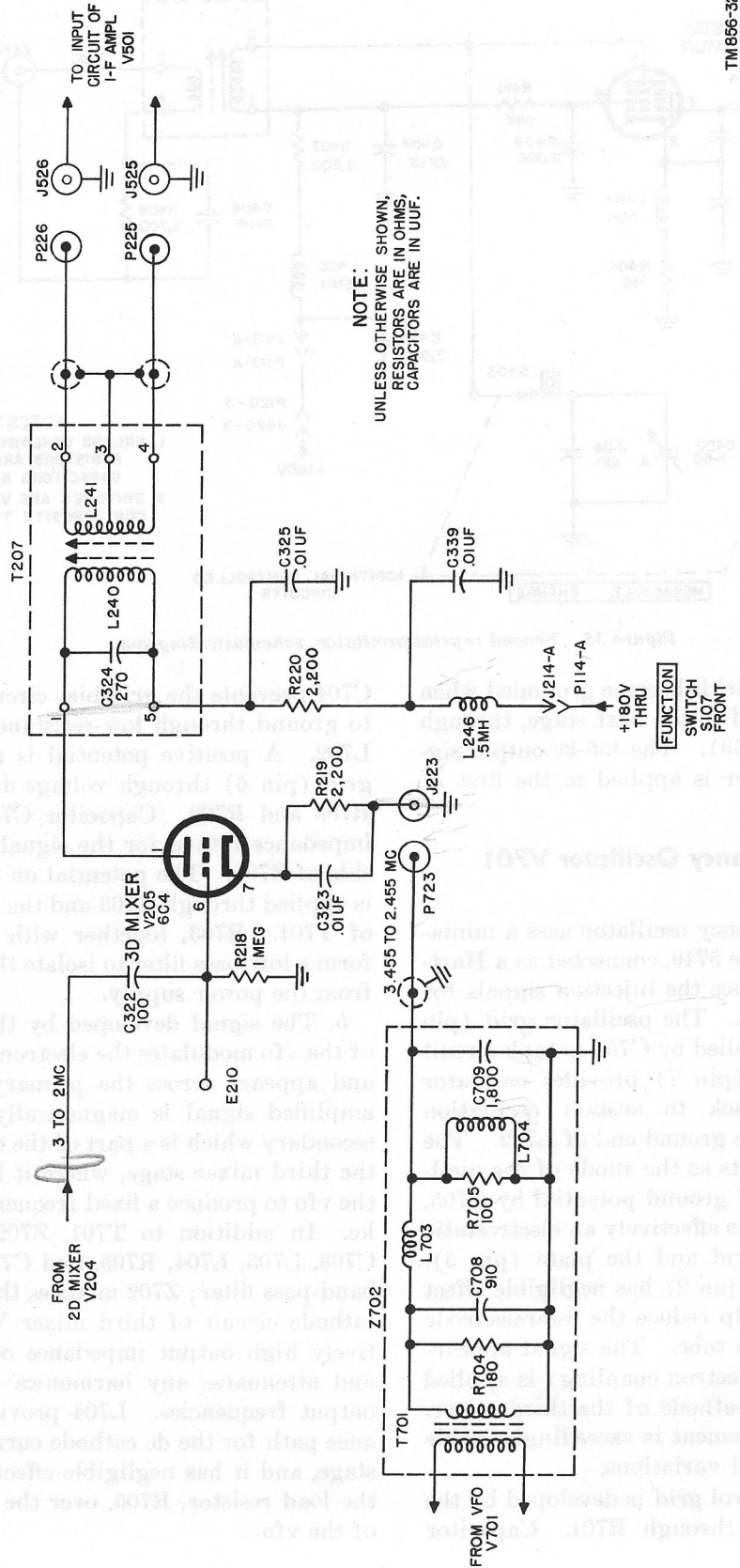

Figure 94. Third mixer stage, schematic diagram.

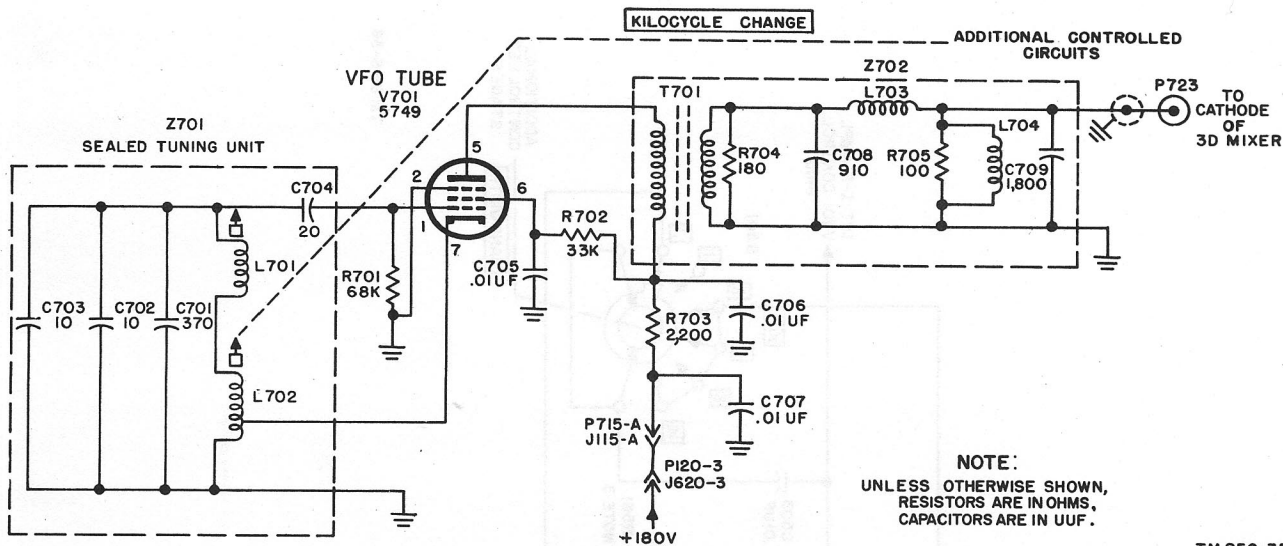

Figure 35. Variable frequency oscillator, schematic diagram.

c. Tuning unit Z701 is inclosed within a hermetically sealed can; the temperature of the tuning unit is maintained at a constant level by a heating element which is wound around the can, and which is designated HR701 on figure 107, part 1. The can should not be opened under any circumstances; the tuning unit is adjusted accurately under laboratory conditions at the factory, and any attempt to perform adjustments except under these conditions would affect the accuracy of the unit seriously. The tuned circuit includes capacitors C701, C702, and C703 connected across the series-connected coils. These capacitors are selected carefully with regard to temperature coefficient so as to achieve a high degree of frequency stability. When the temperature at the receiver location varies over a rather wide range, the stability of the receiver may be increased by turning on the oven heater switch at the rear of the receiver. The oven current is controlled by thermostat switch S701 (fig. 54) to maintain a constant oven temperature of 75° C.

d. As the receiver is tuned from the lowest to the highest frequency within a particular band, a powdered-iron slug within coil L702 is moved to change the frequency of the vfo over a range of 3.455 to 2.455 mc. The slug is moved through the range in exactly 10 turns of a precision lead screw that is coupled mechanically to the KILOCYCLE CHANGE control knob on the front panel. The frequency of the oscillator varies linearly over its entire range because of a precision factory-adjusted mechanism. The inductance

of trimmer coil L701 is also factory-adjusted to obtain a 1-megacycle range for ten turns of the tuning screw. The variation in the inductance of the coil is obtained by adjusting the core of the coil with a screwdriver.

## 59. Crystal Filter (fig. 36)

a. To distinguish between adjacent signals, and to prevent interference from signals of a frequency close to that of the desired carrier may require a pass band as narrow as 100 cps in the 455-kc if. amplifier. Crystal filter Z501 provides the filtering action necessary to establish the two narrow pass bands of 0.1 and 1 kc. It is a part of the bandwidth control system that provides the required degree of selectivity for all modes of operation within the capability of Radio Receiver R-390/URR.

b. The crystal filter has a crystal that is cut for a frequency of 455 kc. The circuit consists basically of one half of the secondary L241 (between terminals 3 and 4), crystal Y501, resistors R502 and R561, and capacitor C502.

c. The inductance L and capacitance C are used primarily to tune out, or cancel, the effects of capacitance found in the grid circuit of first if. tube V501, the wiring, and the adjacent components. This is done to reduce the crystal load circuit to one which is essentially purely resistive, and thus to prevent the crystal from tending to resonate. A variable neutralizing capacitor is connected between one end of the crystal holder

TM 856-35

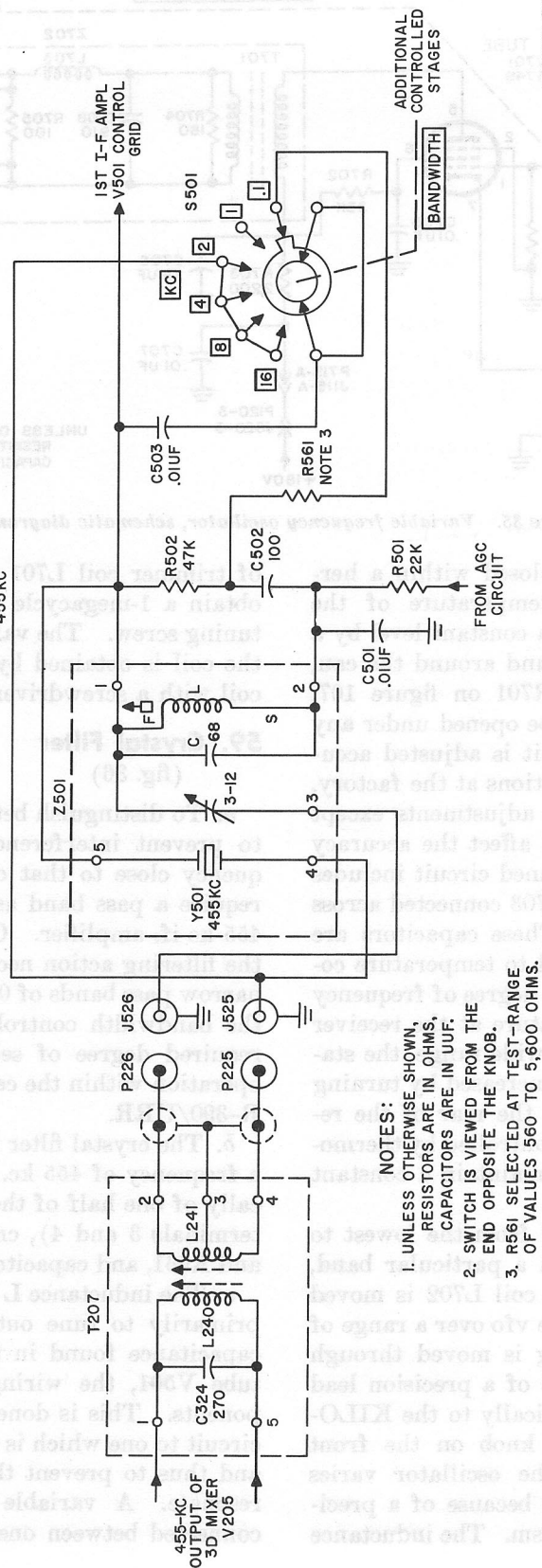

Figure 36. Crystal filter, schematic diagram.

for Y501 and the other half of secondary L241 (terminals 2 and 3). This capacitor feeds a voltage whose amplitude is equal and whose phase is opposite that of the voltage applied from jack J525 across the crystal holder capacitance to the control grid of V501, from jack J526. This out-of-phase voltage serves to neutralize effectively the capacitance of the crystal holder. The output of the third mixer stage is coupled magnetically by transformer T207, through connectors P225 and P226 and jacks J525 and J526 (fig. 34), to crystal filter Z501. When BANDWIDTH switch S501 is in the .1- and 1-KC positions the 455-kc signal is applied to Z501; on the remaining four positions of the control marked 2, 4, 8, and 16 KC, the signal is applied to the control grid (pin 1) of V501 through coupling capacitor C503. Note that with the switch in the last four positions, C503 short-circuits crystal Y501, but in the first two positions, C503 serves as a low-impedance connection at the intermediate frequency to resistor R561.

*d.* With the BANDWIDTH switch in the .1-KC position, the crystal is loaded principally by R502 and C502, but R561 is shunted across R502 through C503. This reduces the total resistance in the circuit; the RC combination which represents the crystal series load becomes essentially capacitive, and the crystal tunes more sharply to resonance. With the BANDWIDTH switch in the 1-KC position, the crystal is loaded principally by R502 and C502, and R561 is removed from the circuit. Since this RC combination is essentially resistive, the circuit Q is lowered, and the width of the pass band is increased. The ratio between the crystal impedance and the resistive load (1-KC position) and the ratio between the crystal impedance and the capacitive load (.1-KC position) are such as to maintain the same gain in the circuit in both cases.

## 60. 455-kc If. Amplifiers

The if. amplifier system, which has a very high gain, consists of six voltage-amplifier stages. The first five if. stages use 6BJ6 miniature pentode tubes V501 through V505; associated if. transformers are T501 through T505. The output of the fifth if. stage supplies signals through the sixth if. stage V506 to the detector V507, through the agc amplifier V509 to the agc rectifier, one-half of V510, and, through the cathode follower, one-half of V511, to the 50-ohm if. output jack,

J512 (fig. 44). The gain of the if. amplifier is controlled manually by the RF GAIN control with the FUNCTION switch set to MGC, AGC, CAL, and SQUELCH. The gain is controlled automatically by the agc circuits, when the FUNCTION switch is in the AGC, CAL, or SQUELCH position. When six amplifier stages using the same power supply are tuned to approximately the same frequency (as in the case in this amplifier), oscillation may occur as a result of coupling between stages, through the common impedance of the power supply. To prevent this, decoupling networks are used in the grid and plate circuits of all if. stages. Additional filtering is provided by choke L503 and capacitors C530 and C531 in the power supply circuit. In addition to the selectivity obtained by the use of crystal filter Z501, four degrees of selectivity are obtainable by varying the coupling between the primary and secondary windings of each of the if. transformers by means of the BANDWIDTH switch.

## 61. First If. Amplifier V501

(fig. 37)

The first if. stage uses a type 6BJ6 miniature pentode tube as a voltage amplifier of 455-kc signals.

*a.* The control-grid circuit of V501 consists of the winding L in the crystal filter (Z501) and R501, which is bypassed by C501. Resistor R501 is connected to the agc circuit. The control grid (pin 1) is returned to the agc circuit or ground through the inductor in Z501, R501, terminals 4 and 3 of TB103, and the rear section of FUNCTION switch S107. Voltage from the agc circuit is applied to terminal 3 of TB102 which, for normal operation, is connected to terminal 4 by a jumper. In the MGC position of the FUNCTION switch, the agc voltage is grounded. In the MGC position of the switch, the dc return path for the grid is through the inductor in Z501 and resistor R501. Under this condition, the stage gain is controlled by the value of the cathode bias (at pin 2) which is established by the setting of the RF GAIN control R123. Minimum-bias is limited by R503. Capacitor C505 bypasses if. on the cathode to ground. C504 and L501 are a low-pass filter used to prevent interference of signals between this and other stages which use the common RF GAIN control. External control of the rf gain can be used by removal of the jumper between terminals RF GAIN 1 and 2 of



TB102 and connecting a 5,000-ohm potentiometer between terminal 1 and ground. In the AGC position of the FUNCTION switch, the voltage from the agc circuit is applied to the control grid and the stage gain is controlled automatically by the average signal level as described in paragraph 68. However, the RF GAIN control is still effective under these conditions. The suppressor grid (pin 7) is connected to the cathode. The screen grid (pin 6) is bypassed for if. to ground by C506 and is connected to the junction of R504 and R505 which form with R562 a voltage divider across the 180-volt supply. The plate (pin 5) circuit is completed to B+ through the primary of T501 and decoupling resistor R506, which is bypassed for if. by C507. Additional filtering of the supply voltage is accomplished by L503 and capacitors C530 and C531, a pi-type filter which prevents rf signals from entering the power supply circuits. The resistor connected across the primary winding of T501 is used to achieve the required band-pass characteristics for this stage.

b. The 455-kc if. signal from the third mixer, V205, is fed to the control grid (pin 1) of V501 either through crystal filter Z501, or directly from the third mixer stage through the contacts of BANDWIDTH switch S501 and coupling capacitor C503. The amplified signals at the plate (pin 5) is coupled by T501 to the control grid of second if. amplifier V502.

c. Three degrees of selectivity are obtainable by connecting one of three windings in transformer T501, through the contacts of BANDWIDTH switch S502. Two of these windings have a series resistor (R507 and R508). These windings and resistors of T501 contribute to the final selectivity of the if. amplifier system. They are discussed in more detail in paragraph 64.

## 62. Second If. Amplifier V502

(fig. 37)

The second if. amplifier uses a miniature pentode tube, 6BJ6 as a voltage amplifier.

a. The grid (pin 1) returns to ground through a portion of the secondary winding of T501. Fixed bias is obtained in the cathode (pin 2) circuit by plate current flowing through resistor R510 and potentiometer R562 which are in series to ground. C509 is the cathode if. bypass capacitor which is used to prevent degeneration in the cathode circuit. The stage gain is preset by a screwdriver adjustment of R562 (GAIN ADJ) during

an alinement procedure (par. 119). The suppressor grid (pin 7) is connected to the cathode. The screen grid (pin 6) is bypassed for rf to ground by C510 and is connected to B+ through voltage dropping resistor R512 to the pi-type filter described in the preceding stage discussion (par. 61). The plate (pin 5) circuit is completed to B+ through the primary winding of T502, decoupling resistor R513 (which is bypassed for rf by C507) and the filter.

b. The output of the first if. amplifier is applied through T501 to the grid of the second if. amplifier. The range in voltage controlled by GAIN ADJ control R562 is increased by bleeder current which flows through resistor R504. R504 is in the screen grid voltage divider circuit of the first if. amplifier stage. The signal is amplified and applied to the third if. stage through T502. To achieve the required bandwidth of the if. amplifiers (4 kc on either side of the intermediate frequency of 455 kc) and at the same time maintain the required receiver sensitivity (2 to 5 microvolts), a comparatively large number of voltage amplifiers must be employed.

c. Four degrees of selectivity can be obtained by connecting one of four windings in transformer T502, through the contacts of BANDWIDTH switch S503. Two of these windings have series resistors (R514 and R515). These components contribute to the final selectivity of the if. amplifier system and are discussed in more detail in paragraph 64.

## 63. Third and Fourth If. Amplifier V503 and V504

(fig. 38)

Both the third and fourth if. stages use a miniature pentode tube, type 6BJ6. Their operation is the same as that of the second if. stage, except for certain differences, which are discussed below.

a. Cathode bias for V503 and V504 is decreased as the BANDWIDTH control is rotated from the .1-KC position to the 16-KC position, to prevent the gain of the if. stages from decreasing. (In the ordinary if. stage, as bandwidth is increased the overall stage gain is decreased.) Resistors R518 through R521 are connected, by means of the slider of BANDWIDTH control S504, to fixed bias resistors R517 and R526 of the cathodes (pin 2) of V504 and V505, respectively. The resistors are introduced in series with the fixed bias resistors to decrease the control-grid bias and thereby increase

the gain proportionately as the band-pass is increased. These resistors are selected to meet gain requirements for individual if. amplifiers during manufacture. If these resistors require replacement, the original values should be duplicated. The cathodes are bypassed for rf to ground by capacitors C514 and C513. The suppressor grids (pin 7) are connected to the cathodes.

b. The signal from the second if. amplifier is fed through coupling capacitor C512 to the control grid (pin 1) of V503 which is returned to ground by R516. This grid leak resistor is necessary because the common gain adjusting resistors are used in the cathode circuits of V503 and V504. A sudden strong signal, or a noise impulse at the grid of V503, causes it to draw grid current momentarily before the agc circuit can take control and reduce the signal strength. This grid current, flowing through the common cathode circuit of V503 and V504, produces an additional bias voltage which would block V504. Thus, no signal would reach the agc circuit and the receiver would remain blocked until the input signal to V503 was reduced. R516 limits the flow of grid current to a very small amount which has negligible effect on the cathode bias and prevents blocking. R522 and R527 are voltage dropping resistors for screen grids (pin 6) of V503 and V504, respectively. The screen grids are bypassed for rf to ground by capacitors C515 and C518. The plate (pin 5) of V503 is connected to B+ through the primary winding of T503, R523, and L503. The plate of V504 is connected to B+ through the primary winding of T504, R528, and L503. R523 with C516 and R528 with C519 decouple the plate circuits from the common B+ circuits.

c. The amplified signal at the plate of V503 is coupled by T503 to the control grid (pin 1) of V504. The amplified signal at the plate (pin 5) of V504 is fed in a similar manner through T504 to the control grid of V505.

d. Four degrees of selectivity can be obtained by connecting one of four windings in transformers T503 and T504, through BANDWIDTH switches S505 and S506. A small capacitor across each primary and an RC network in series with each secondary provide the required pass band. Two of the windings in each transformer have series resistors. Resistors R524 and R525 are used for T503, and resistors R529 and R530 are used for T504. These components contribute to

the final selectivity of the if. amplifier system and are discussed in more detail in paragraph 64.

#### 64. Fifth If. Amplifier V505

(fig. 39)

The fifth if. amplifier uses a miniature pentode tube, 6BJ6. This stage is similar in operation to the previous if. stages except for certain differences which are discussed below.

a. The grid (pin 1) of V505 returns to the agc circuit through part of the secondary winding of T504, resistor R509, and FUNCTION switch S107 rear. If. signals are isolated from the agc circuits by decoupling resistor R509 which is rf bypassed to ground by C508. The operation of the FUNCTION switch and agc circuit are the same for this stage as described for the first if. amplifier stage (par. 61). The cathode (pin 2) is connected to the suppressor grid (pin 7) and returns to ground through bias limiting resistor R531, the RF GAIN terminals 1 and 2 of TB102 and the RF GAIN control R123. C520 is the cathode bypass capacitor. The operation of the RF GAIN control is the same as that described for the first if. stage except that the level of the signals at this stage is much higher and therefore additional isolation of the cathode circuit from the other controlled stages is provided by L501. The screen grid (pin 6) is bypassed for rf to ground by C521 and is connected to the junction of R511 and R532 which form a voltage divider across the 180-volt supply. The plate (pin 5) circuit is completed to B+ through the primary winding of T505 and decoupling resistor R533 which is bypassed for rf by C522. Additional filtering of the supply voltage is accomplished by L503 and capacitors C530 and C531, a pi-type filter which prevents rf signals from entering the power supply circuits.

b. The 455-kc signal from the previous amplifier, V504, is coupled, through T504, to the control grid of V505. The output of the plate of V505 is coupled by T505 to the control grid of V506.

c. The band pass of the if. amplifier system can be varied in six steps by the BANDWIDTH control over a range extending from .1 KC to 16 KC. This range is obtained by the effects of the crystal filter (Z501) and by controlling the mutual coupling between the windings of the interstage transformers (T501 through T505). The operation of the crystal filter is discussed in paragraph 59. Mutual coupling in the transformers is controlled by the use of coils wound on the same

form as the primary or secondary winding. Three of these coils are used in T501 (fig. 108, part 2) while four are used in the remaining if. transformers. The effect of these coils is to aid or oppose (depending on how they are connected) the mutual coupling which exists between the primary and secondary windings of the transformer. When the mutual inductance is increased, the bandwidth is broadened and when the mutual inductance is decreased, the bandwidth is narrowed. The coils shown schematically nearest to the secondary windings are effective in obtaining the widest bandwidth. Transformers T502, T503, T504 and T505 include those coupling coils which are phase opposing. These provide the sharpest selectivity, because the smallest degree of coupling exists between the primary and secondary windings. One coupling coil at a time is connected in each transformer to produce a given degree of inductive coupling.

d. A series coupling circuit, that includes contacts of BANDWIDTH switch, a selected coupling coil, and a capacitor connected in parallel with a resistor, is connected across each secondary winding to obtain a given bandwidth. Resistors of different values in series with the coupling coils also may be included, when needed, to increase the bandwidth. Each of the primary and secondary windings is covered by a magnetic cup, and is alined by a powdered iron slug.

(1) When the BANDWIDTH switch is in the position marked .1, 1, or 2 KC, transformer coupling circuits remain unchanged; narrow bandwidths for the .1-KC and 1-KC positions depend on circuit changes in crystal filter Z501. In these three positions of the BANDWIDTH switch, the coupling coil which is phase aiding and mounted at the greatest distance from the primary winding of transformer T501 is in the circuit.

(2) When the BANDWIDTH switch is in the 4-KC position, the coupling circuit of transformer T501 remains the same as noted in (1) above. Coupling coils that are phase aiding and located at the greatest distance from the primary windings of T502, T503, T504, and T505 are used.

(3) When the BANDWIDTH switch is in the 8-KC position, the middle coupling coil of transformer T501 and series resistor, R507 are connected into the cou-

pling circuit. The coupling coils in the second positions from the primary windings of transformers T502 through T505 and series resistors R514, R524, R529, and R534 are included in the remaining coupling circuits. In this switch position, the windings of transformer T501 are not coupled as closely as the windings of T502, T503, T504, and T505, therefore the single-peak frequency response of T501 fills in between the double-peak frequency response of the succeeding circuits, which are overcoupled.

(4) When the BANDWIDTH switch is on the 16-KC position the nearest coupling coil of transformer T501 and coupling coils that are nearest the primary windings of the four other transformers are included in the coupling circuits. Resistor R508 is in series with the coupling coil of transformer T501, and resistors R515, R525, R530, and R535 are in series with the coupling coils of T502, T503, T504, and T505. As in the 8-KC position, the first circuit provides sharper selectivity than the succeeding circuits, compensate for double-peak frequency response caused by overcoupling.

Figure 39. Fifth and sixth if. amplifiers, schematic diagram.

(Contained in separate envelope)

## 65. Sixth If. Amplifier V506

(fig. 39)

The sixth if. amplifier uses a miniature pentode tube, 6AK6. This stage is similar in operation to the previous if. stages, except for certain differences, which are discussed below.

a. Cathode bias (adjustable by a screwdriver control) is provided by resistor R536 and potentiometer R537, in series. The cathode is rf bypassed to ground by capacitor C523. The control grid (pin 1) of this stage is returned to ground through part of the secondary of T505. B+ voltage to the screen grid (pin 6) and the plate (pin 5) is supplied from the same dc potential source through decoupling resistor R538. The screen and plate return circuits are rf bypassed to ground by C524.

b. The 455-kc signal from fifth if. amplifier V505 is applied through T505 to the control grid

of V506, through C539 to the grid of agc amplifier V509, and to the grid of the cathode follower, section B of V511. The amplified signal appearing at the plate of V506 is coupled inductively by T506 to the detector, section A of V507.

c. Capacitor C525 neutralizes the interelectrode capacitance between the plate and the control grid of the sixth if. amplifier. This prevents the output signal from beat-frequency oscillator V508 (which is applied to the secondary of T506) from appearing in the output of the if. cathode follower. In addition to providing fixed bias, variable resistor R537, designated CARR-METER ADJ, is used in the carrier level meter (M102) circuit discussed (par. 68).

d. Transformer T506 does not have provision for varying the selectivity. The 22,000-ohm resistor across the primary winding, together with the coil and capacitor across the secondary winding, permits any degree of bandwidth selected in the previous stages to pass through the transformer to the detector without attenuation.

## 66. Detector and Limiter Circuits

(fig. 40)

The detector demodulates the 455-kc if. signal, to recover the intelligence from the signal for most types of operation of Radio Receiver R-390/URR. The limiter minimizes interference by removing noise peaks which exceed the amplitude of modulation. The detector and limiter circuits are discussed together because the output of the detector always is applied through the limiter circuit to af amplifier, section A of V601.

a. *Detector.* The detector supplies an audio signal for application to the limiter and af stages.

- (1) The detector uses one-half of V507, a type 12AU7 miniature twin-triode tube, connected as a half-wave diode rectifier. The plate and control grid (pins 1 and 2) act as an anode, which is connected to the secondary of T506. The ground-return circuit from the secondary includes choke L502 and the diode load, which consists of resistors R539 and R540. The cathode (pin 3) is grounded.
- (2) The if. signal from the sixth if. amplifier is applied through T506 to the detector anode. During each positive half-cycle of the if. signal, the anode is positive and the tube conducts. Choke L502 and capacitor C526 block the if. signals from

the diode load, but permit the audio variations to pass, so that an af voltage appears across the load. Audio output is taken from two points: The af voltage developed across R540 is applied, through coupling capacitor C527, to the negative-peak limiter, one-half of V507. The af voltage developed across both R540 and R539 is applied, through a jumper connection on TB101, to the control grid of the squelch tube, one-half of V601. The dc voltage developed across the diode load is of negative polarity. LIMITER control R124, shunted across the load, provides an adjustable, negative voltage, for use in setting the operating level (threshold) of the limiters.

- (3) The output of the bfo is coupled to the detector plate through capacitor C536. The bfo signal beats with the if. input signal to produce a beat note (par. 67).

b. *Limiter.* The limiter couples the audio signals from the detector to the audio stages. When limiter switch S105 is on, the peak amplitude of the detector output is limited to eliminate noise peaks above a certain threshold.

- (1) The limiter circuit employs two triode tube sections, connected as diode series limiters, to provide limiting of both positive and negative noise peaks. The negative-peak limiter uses one-half of V507, a type 12AU7 miniature twin-triode tube, and the positive-peak limiter uses one-half of V510, another 12AU7 tube. When LIMITER control R124 is turned to OFF, switch S105, which is ganged to the limiter potentiometer, grounds the parallel-connected cathodes through R544, and removes the ground connection at the junction of resistors R541 and R542; this permits the plate to become positive because +180 volts now is applied through L503 and R543. With the plates of both diodes at a positive potential and both cathodes grounded, a direct current flows through both diodes. The af signal voltage that is applied to the anode of section B of V507 superimposes itself on (modulates) the dc flowing through this diode and, as a result, the af signal appears across cathode resistor R544. Since this resistor is common to

the diode load, but permit the audio signal to pass, so that an AF voltage appears across the load. Audio output is taken from two points: The AF voltage developed across R540 is coupled through capacitor C527 to the negative limiter, one-half of V507. The AF voltage developed across both R540 and C529 is coupled to the positive limiter, one-half of V510. In addition to providing fixed bias to the detector, the secondary of T506 (which is applied to the control grid of the sixth IF amplifier) provides a frequency oscillator V505 but signal feedback is prevented by the capacitor C550. This prevents the oscillator from appearing in the output of the IF amplifier. In addition to providing fixed bias to the detector, the secondary of T506 (which is applied to the control grid of the sixth IF amplifier) provides a frequency oscillator V505 but signal feedback is prevented by the capacitor C550. This prevents the oscillator from appearing in the output of the IF amplifier.

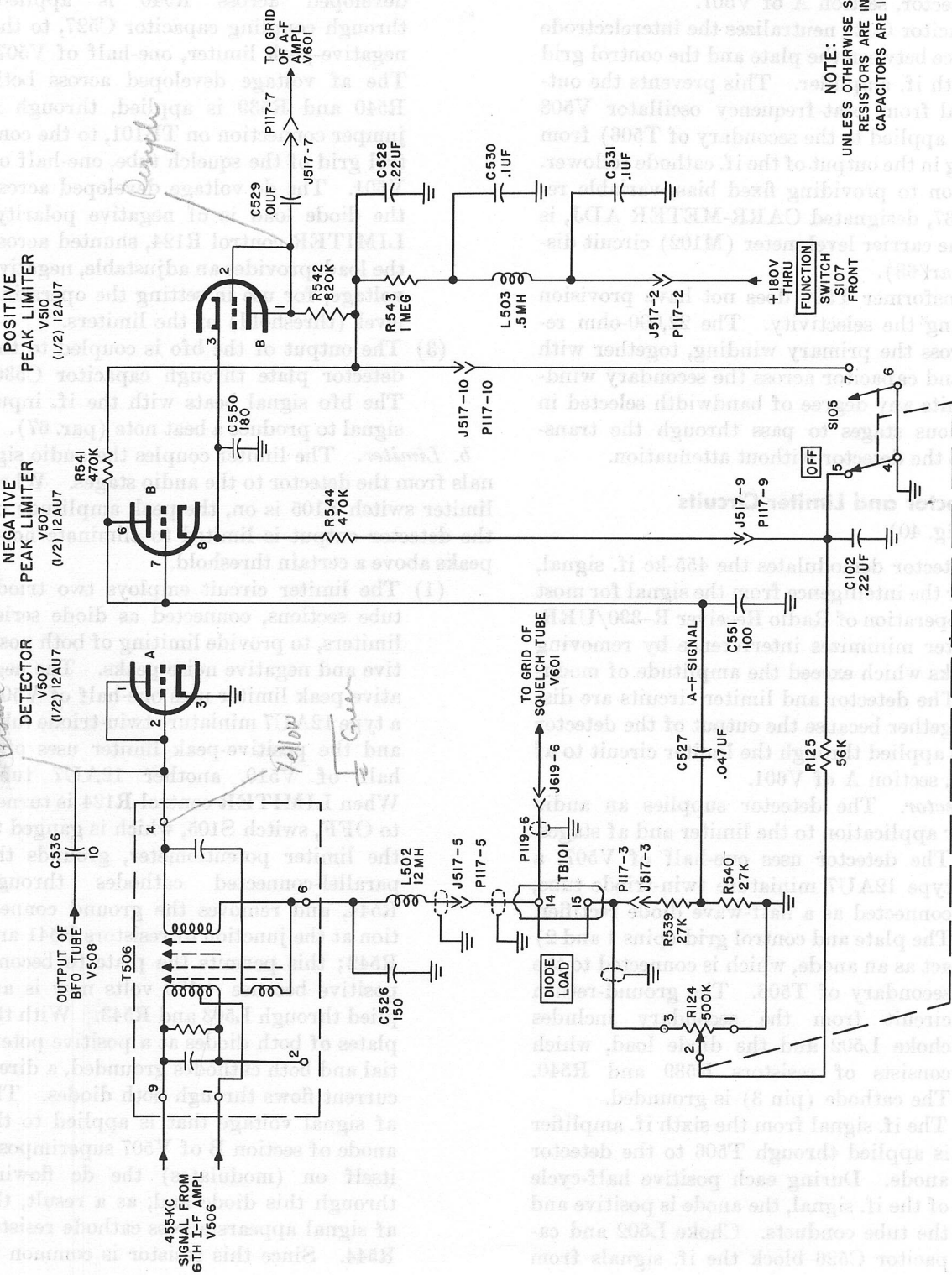

Figure 40. Detector and limiter circuits, schematic diagram.

both diode circuits, the af signal is also superimposed on the dc flowing through section B of V510 and appears across R542 at the plate. From this point, the signal is coupled through C529 to the grid of the first af amplifier section A of V601. L503, together with C530 and C531, is a decoupling network and, in the OFF position of S105, R543 and C528, perform the same function. The purpose of C551 is to bypass to ground any if. that might be present in the output of the detector stage. R125 prevents excessive loading of the detector output as a result of the grounding of cathode resistor R544.

- (2) When the LIMITER control is turned clockwise, switch S105 grounds the junction of plate resistors R541 and R542 and removes the ground on the cathodes of the diodes. As a result, the cathodes assume a negative threshold potential which is adjustable by means of LIMITER potentiometer R124. The diodes thus are converted into negative (one-half of V507) and positive (one-half of V510) peak limiters. Again, a direct current flows through the diodes and as long as it flows, the af signal is transferred through the diodes as before. However, any negative-going impulse that drives the plate of V507 more negative than the cathode will cut off the diode, and that impulse will be limited to an amplitude equal to the threshold voltage. Similarly, any positive impulse that overcomes the threshold potential on the cathode of V510 will cut off that diode, and the positive impulse will be limited. As the LIMITER control is turned toward position 10, a less negative threshold voltage is applied to the diodes, and more severe limiting results. Since the threshold voltage at any given setting of the LIMITER control varies with the average amplitude of the diode load signal, the limiting action automatically adjusts itself—at low modulation levels, greater limiting takes place, and at high modulation levels less limiting takes place. C102 and R125 decouple the limiter circuit from the detector circuit.

C550 stabilizes the threshold voltage at the cathodes.

## 67. Bfo Tube V508

(fig. 41)

To facilitate accurate tuning of signals and to permit the reading of radiotelegraph signals, the bfo is used. When BFO switch S103 is set to ON, the bfo generates a signal which is mixed with the 455-kc if. signal at the input to the detector one-half of V507. The two signals heterodyne to produce an audible beat frequency in the output of the receiver. The bfo employs a miniature pentode tube, type 5749, connected as a Hartley oscillator, and its operation is similar to that of vfo (par. 58).

a. Bias for the control-grid (pin 1) is developed by the flow of grid current through R545. Capacitor C532 prevents short circuiting the grid-bias voltage to ground through the low-resistance tank coils of Z502. B+ voltage is applied to the screen grid (pin 6) through contacts 4 and 2 of BFO switch S103 and voltage-dropping resistors R548 and R546. These resistors are bypassed by capacitors C534 and C535 to insure oscillator frequency stability. Capacitor C534 also provides a low-impedance signal path to the ground side of Z502. B+ voltage to the plate is taken from the junction of R546 and R548 and fed through R547. The bfo output signal is developed (by electron coupling to the plate) across resistor R547. The decoupling network formed by R548 and C535 isolates the oscillator from the power supply. When the BFO control is turned to OFF, B+ voltage is removed from the plate and screen circuits of the oscillator.

b. The oscillator section is a triode in which the screen grid (pin 6) acts as the anode. The control grid (pin 1) is connected, by capacitor C532, to tuned circuit Z502, which consists of a tank coil (two inductors connected in series) and a tank capacitor (three capacitors connected in parallel). The cathode of V508 (pin 2) is connected to a tap on the tank coil. The feedback voltage required to produce and sustain oscillation is induced in the coil by the flow of cathode current through the portion of the coil that is connected between the tap and ground. This voltage is applied to the control grid through coupling capacitor C532. Since the oscillator output is coupled into the plate circuit by the electron flow within the tube, variations in plate load have little

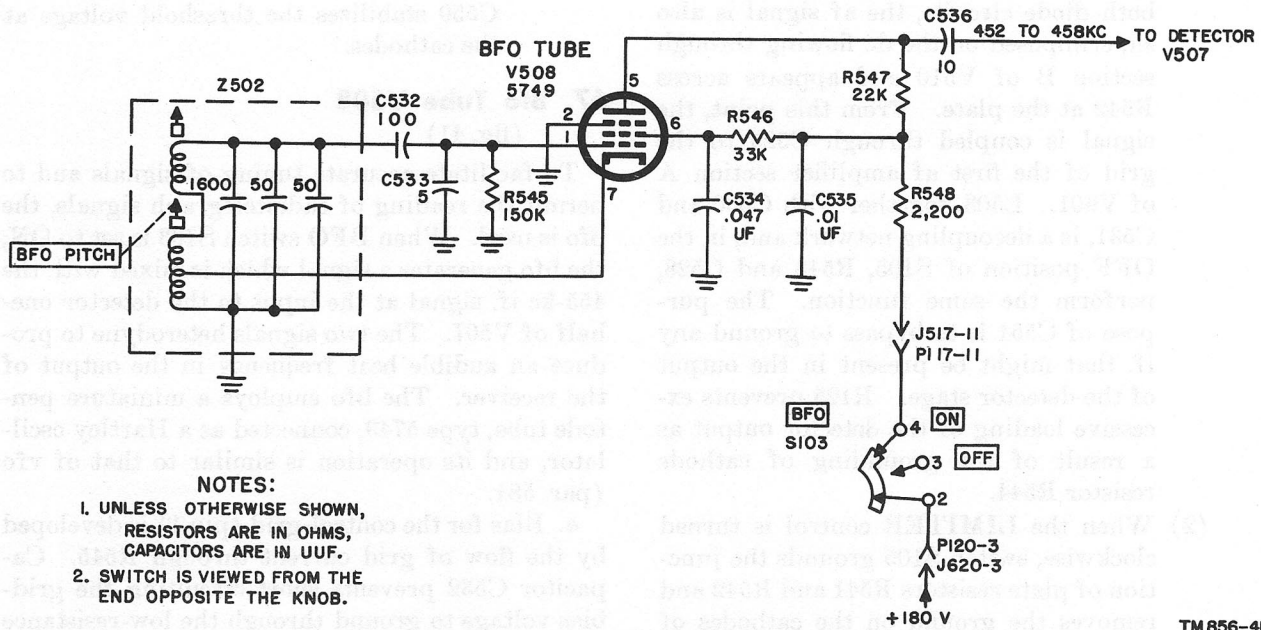

Figure 41. Beat-frequency oscillator, schematic diagram.

effect on oscillator stability. The amplified signal from the plate is coupled, through capacitor C536, to the plate of the detector one-half of V507.

c. Capacitors C532 and C533 form a voltage-divider network which improves frequency stability by placing the grid input capacitance of V508 across only part of the tank coil. The three capacitors across the series-connected coils are selected carefully for the correct temperature coefficient to insure frequency stability over a wide range of temperature. The tuning unit, Z502, is inclosed within a hermetically sealed can. The can should not be opened under any circumstances. The tuning unit has been adjusted accurately, baked, and sealed under laboratory conditions at the factory. Any attempt to perform adjustments except under these conditions will affect the accuracy of the unit seriously.

d. The audio frequency produced by this mixing action in the second detector may be varied by varying the oscillator frequency over a range of 452 to 458 kc. This is accomplished by varying the degree of insertion of the powdered-iron core within the coil of Z502 (BFO PITCH control). When the control knob on the front panel is set to 0, the output of the bfo is exactly 455 kc and therefore no heterodyne frequency is produced in the detector. Thus, the zero position of the control knob represents a bfo frequency of 455 kc, and

the calibration indicates the number of kilocycles separation ( $\pm 3$ ) from the bfo frequency.

### 68. Agc Circuit (fig. 42)

When FUNCTION switch S107 is turned to AGC, CAL, or SQUELCH, the agc circuit is operative. In the MGC (manual gain control) position, the agc control line is disabled (grounded). The agc circuit develops a negative dc potential which is related in amplitude to the strength of the incoming signal. To maintain the receiver output at a constant level regardless of signal-strength variations, this negative dc potential is used to bias the grids of the first and second rf amplifiers, V201 and V202, and the first and fifth if. amplifiers, V501 and V505. (In this discussion these tubes will be designated as the *controlled tubes*.) The delayed-action system functions to prevent the application of agc bias to the controlled tubes during the reception of weak signals, so that maximum receiver gain may be realized. The time-constant system permits three degrees of response to be selected by the AGC control. Depending on the type of fading experienced and the type of signals being received, the control is set to FAST, MED., or SLOW, and thus insures maximum effectiveness of the agc circuit. (A fading signal is an incoming rf signal that is alternately strong and weak over a given

period of time.) The circuit makes use of a miniature pentode tube, type 6BJ6 (V509) and two miniature twin-triode tubes type 12AU7 (one-half of V510 and one-half of V511). Agc amplifier V509 is a voltage amplifier operating at 455 kc; one-half of V510, connected as a diode, is used as a rectifier.

*a. Agc Amplifier.* This stage (V509), except for certain modifications, is similar in operation to if. amplifiers V501 through V506 (pars. 61 through 65).

- (1) The 455-kc signal from the secondary of T505 in the fifth if. amplifier stage is coupled to the control grid (pin 1) of V509 through C539, producing grid bias across R551 at high signal inputs. This resistor also serves as a dc return path to ground. Cathode bias is developed across R552, which is bypassed for if. by capacitor C540. The screen grid is supplied with dc potential through voltage-dropping resistor R553; C541 is the screen grid bypass capacitor. The suppressor grid (pin 7) is connected as a part of the delayed agc circuit. The plate (pin 5) receives B+ voltage through decoupling resistor R554 and the coil of Z503. Capacitor C542 and R554 form a plate circuit decoupling network.
- (2) The amplified signal from the plate is developed across the high impedance of tuned circuit Z503. The signal is coupled, through C543, to the plate of the agc rectifier, one-half of V510. The coil of Z503 has a powdered-iron core which is adjusted for maximum output during alinement.

*b. Delay Agc System.* The purpose of delaying agc action is to prevent the application of negative bias to the control tubes unless the if. signal has sufficient strength to produce adequate input to detector V507. Maximum gain is therefore available for the reception of weak signals.

- (1) The agc function is made dependent on the strength of the received signal by the action of the circuit consisting of voltage dividers R558, R556, and R555, the suppressor grid of V509, and the agc rectifier, one-half of V510. This circuit produces a positive potential on the agc bus which is too small to overcome the nega-

tive grid bias produced by the cathode resistors of the controlled tubes.

- (2) During the positive peaks of if. signal, the agc rectifier V510 offers low impedance to ground; therefore positive peaks do not generate voltage in the diode circuit. During intervals when the applied voltage is negative, the diode is not conducting, and a pulsating negative voltage is developed in the plate circuit across resistor R555. This pulsating voltage is filtered by resistor R556 and capacitor C544. C544 also presents a low-impedance path to ground for the if. signal at the suppressor grid of V509. Under this condition, the junction of R556 and R558 is nearly at ground potential because of the high voltage drop across R558. This voltage drop is produced by the negative voltage from the agc rectifier and the flow of current into the suppressor grid (pin 7) of V509.
- (3) However, if a strong signal is applied through C543 to the agc rectifier, a negative dc voltage will be developed across R555, in opposition to the positive voltage appearing at the junction of R556 and R557. For input voltages greater than this positive value (threshold), the negative voltage will exceed the positive voltage, and the flow of suppressor-grid current will cease. When this occurs, the negative voltage that is in excess of the positive voltage is applied through R557 and the time-constant circuit to the agc line, and thus the gain of the controlled tubes is decreased.
- (4) The agc voltage is fed, through AGC NOR terminals 3 and 4 (fig. 22), to the grid circuits of the four controlled tubes (V201, V202, V501, and V505). Resistors R202, R208, R501, and R509 and capacitors C226, C252, C501, and C508 form decoupling circuits which isolate if. and rf circuits from each other and the agc line. The agc line is short-circuited to ground when FUNCTION switch S107 is turned to the MGC position. In the MGC position of S107, the gain of the receiver is controlled solely by RF GAIN control R123. Terminals 3 and 4 of TB102 normally are connected



together by a jumper. Crystal CR101 prevents loading of the age circuit of the controlling receiver by age circuits of other receivers in diversity systems. The voltage supplied by the age circuit of the controlling receiver further reduces the gain in the passive receiver.

*c. Time-Constant System.* The time constant of the age line (the time required for the age voltage to drop to 37 percent of its initial value when the signal is removed) is adjustable in three steps by AGC switch S104. In the FAST position, the time constant is .01 second; in the MED. (medium) position, .5 second; and in the slow position, 4 seconds.

- (1) *FAST.* In the FAST position, the ability of the age control voltage to follow fading is maximum; therefore this position is excellent for communication work where rapid nonselective fading prevails. The negative age voltage from the if. signal filter (resistor R556 and capacitor C544) is applied to the second filter (resistor R557 and capacitor C545) for af filtering. The time constant is determined solely by the capacitance and resistance connected to the age line.
- (2) *MED.* In the MEDIUM position, capacitors C546 and C547 are connected across C545 by switch S104, so that the time constant of the age line is increased.
- (3) *SLOW.* In the SLOW position, the ability of the receiver to follow fading is minimum, but this position is very useful for telegraphy work since the age holds receiver gain constant between code groups. When AGC switch S104 is in this position, capacitors C546 and C547 are still used to determine the time constant, but their capacitance appears to be about 10 times as large as in the MED. position. This apparent increase in value is achieved by Miller effect in the triode section, one-half of V511, a miniature duo-triode 12AU7. One-half of V511 is a dc amplifier with the control grid connected to the age line; plate (pin 6) is connected through load resistor R560 to B+. The amplified age voltage across R560 is applied to capacitors C546 and C547. The capacitance between control grid (pin 7) and plate (pin 6),

in this case 2 microfarads ( $\mu\text{f}$ ), is multiplied by the gain of the tube to give a total apparent input capacitance between control grid and cathode (pin 8) of 26  $\mu\text{f}$ . This capacitance, together with the remaining capacitance and resistance of the age line, further increases the time constant. Cathode resistor R559 serves as part of the bridge circuit for the CARRIER LEVEL meter M102.

*d. CARRIER LEVEL Meter Circuit* (figs. 42 and 43). The CARRIER LEVEL meter indicates the relative strength of incoming carrier signal to assist in tuning, calibration, and alignment. B+ voltage is applied to the plates of V506 and section A of V511, through filter choke L503. Capacitors C530 and C531 and L503 form a decoupling network. R538 provides additional decoupling for sixth if. amplifier V506, and R560 is the plate load resistor for age time constant tube V511. The cathode (pin 7) of V506 returns to ground through minimum bias resistor R536 and CARR-METER ADJ control R537. The cathode resistor for V511 is R559. The CARRIER LEVEL meter, M102, is connected between the cathode of V511 and the junction of R536 and R537. For simplification, the remaining circuit elements of the sixth if. amplifier and those of the time constant tube are not shown on the simplified schematic (fig. 43). The equivalent resistances of V506 and V511 are shown as resistors connected by dashed lines to the cathodes and plates of the tubes. The input to the circuit is the age voltage from the age rectifier, one-half of V510. The circuit arrangement is a bridge with the plate circuits of V506 and V511 as the upper arms and the cathode circuits as the lower arms. V506 is a pentode and has a relatively high value of resistance which is constant. The voltage drop across this resistance is constant and provides, with R536 and R537, a steady reference voltage to CARRIER LEVEL meter M102. The equivalent resistance of the age time constant tube, which is in series with R559, is changed readily. In the absence of age voltage, as a result of no carrier being received or the carrier level being below the threshold of the age circuit, no bias is applied to the control grid (pin 7) of V511. Under these conditions, the voltage drop across the triode and the pentode is the same since they are effectively in parallel across the same power supply. No difference of potential exists across meter M102.



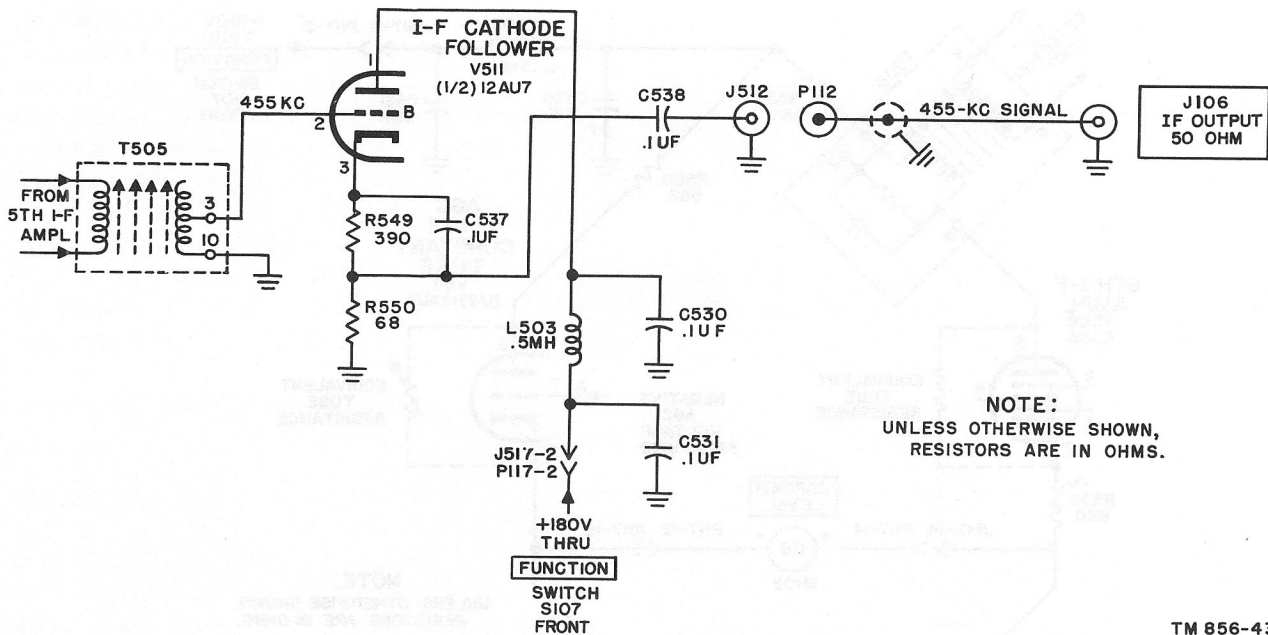

TM 856-43

Figure 44. Cathode follower, schematic diagram.

effect on the input circuit, and no gain or distortion is introduced in this type of circuit.

## 70. Af Amplifier and Filter Circuit (fig. 45)

Af amplifier, one-half of V601, amplifies the audio signal from the positive-peak limiter and applies the signal through the filter circuit to the local audio and the line audio channels. The filter circuit selects the range of and eliminates certain audio frequencies that are applied to the local and line audio channels; therefore noise and interfering signals are reduced appreciably in the output circuits and greater intelligibility of received signals results.

a. Bias voltage for the af amplifier, one-half of V601, is developed across cathode resistor R602, which is connected between cathode (pin 8) and ground. The control grid (pin 7) returns to ground through resistor R601. B+ is applied to the plate (pin 6) through choke L601, resistor R603, and the primary of transformer T601. Resistor R603 and capacitor C601 form a decoupling circuit for the plate. Additional decoupling and filtering for all the af stages is provided in the B+ line by choke L601 and capacitor C103. The decoupling circuits, by presenting a low-impedance path to ground for the af signal, prevent audio modulation of the B+ voltage which would cause interference in other circuits.

b. The audio signal output from the limiters is developed across grid resistor R601 and applied to the control grid of section A of V601. After amplification, the signal appears across the primary of transformer T601. Capacitor C602, which is in parallel with the primary of transformer T601, improves the frequency characteristics of the stage by correcting the transformer impedance in the middle and upper af ranges. From the secondary of transformer T601, which has a nominal impedance of 600 ohms to match the input of the filter circuits, the signal is applied through the filter to LINE GAIN potentiometer R103, LOCAL GAIN potentiometer R104, and resistor R105, which are connected in parallel and also have a nominal impedance of 600 ohms to match the output of the filter circuit. The portion of the signal voltage that is applied to the line audio channel depends on the position of the arm of LINE GAIN potentiometer R103, and the portion of the signal voltage that is applied to the local audio channel depends on the position of the arm of LOCAL GAIN potentiometer R104.

c. Before the signal arrives at the LINE GAIN and LOCAL GAIN potentiometers, it passes through AUDIO RESPONSE switch S102. In the WIDE position of this switch, no frequency-selective circuits are inserted into the signal path; in the MED. position, the low-pass filter is inserted; and in the SHARP position, the band-pass

filter is inserted. These filters determine the range of frequencies that will be applied to the input of the succeeding stages. To maintain the same signal level regardless of the setting of switch S102, attenuator pads are connected into the circuit in the WIDE and MED. positions of the switch. These pads, consisting of R106, R107, and R108 in the MED. position, and R109, R110, and R111 in the WIDE position, bring the total insertion loss in these positions up to that in the SHARP position. The MED. position of the switch is for use when the greatest intelligibility of voice reception is desired. Filter FL602 attenuates the higher audio frequencies as well as noise or adjacent-channel interference that might appear when the WIDE position is used. In addition, filter FL602 is used with the line audio channel to prevent cross talk (or splattering) in telephone lines as a result of the presence of high-frequency audio components which tend to couple into adjacent lines through the capacitance between the lines. In the SHARP position, the input to the local and line audio channels is fed through an 800-cps bandpass filter (FL601). This filter is designed to attenuate by at least 6 db all signals below 600 cps and above 1,000 cps, and by at least 30 db all signals below 400 cps and above 1,200 cps. In this position, the reading of radio telegraph signals is made easier by excluding noise and adjacent-channel interference.

*Figure 45. Af amplifier, schematic diagram.*

(Contained in separate envelope)

## 71. Local Audio Channel

(fig. 46)

The local audio channel consists of two stages of Class A amplification. The first stage, local af amplifier one-half of V602, amplifies the audio signal from the af amplifier and applies this signal to the second stage. The second stage, local af output tube V603, amplifies the power of the audio signal from the local af amplifier to a suitable level for operating a loudspeaker or a headset. Three different types of feedback are incorporated in this channel to obtain the required output impedance and frequency response.

*a.* Bias voltage for the local af amplifier is developed across resistors R604 and R609, which are connected in series between cathode (pin 3) and ground. The control grid (pin 2) returns to

ground through LOCAL GAIN potentiometer R104. B+ is applied to the plate (pin 1) through plate load resistor R605 and choke L601. Choke L601 and capacitor C103 form a low-pass filter. This circuit provides filtering and prevents audio signals from entering the common power supply circuits. Bias voltage for V603 is developed across resistors R608 and R609, which are connected in series between cathode (pin 7) and ground. The control grid (pin 1) returns to ground through resistor R607. B+ voltage from the filter circuit is applied directly to the screen grid (pin 6) and through the primary of transformer T602 to the plate (pin 5).

*b.* The signal voltage from the af amplifier is developed across the total resistance of LOCAL GAIN potentiometer R104. A portion of this signal voltage, depending on the position of the potentiometer arm, is applied to the control grid (pin 2) of V602. The signal is amplified in V602 and appears across plate load resistor R605. The signal then is applied to the control grid (pin 1) of V603, through coupling capacitor C603, where it is power-amplified. The output from the stage is impedance-matched to 600 ohms by transformer T602. The primary of transformer T602 is shunted by capacitor C604, which improves the frequency characteristics of the stage by correcting the transformer impedance in the middle and upper audio-frequency ranges. The secondary winding consists of two single windings connected in series by a jumper between terminals 4 and 5. One end (terminal 6) is connected to ground. The signal across the secondary winding is applied across resistors R127 and R128, which are connected in series between terminal 3 of transformer T602 and ground. The signal across resistors R127 and R128 is applied to pin H on REMOTE CONTROL jack J105 and terminal 6 of TB102. The REMOTE CONTROL jack (pin H) is for sidetone connection from an associated transmitter. The signal from terminal 6 of TB102 normally is applied to a speaker, and the signal from terminal 8, which is at a lower power level because of the voltage divider action of resistors R127 and R128, normally is applied to a headset. To facilitate connections, the signal from terminal 8 of TB102 is also available at PHONES jack J103 on the front panel of the radio receiver.

*c.* Negative voltage feedback, negative current feedback, and positive voltage feedback circuits

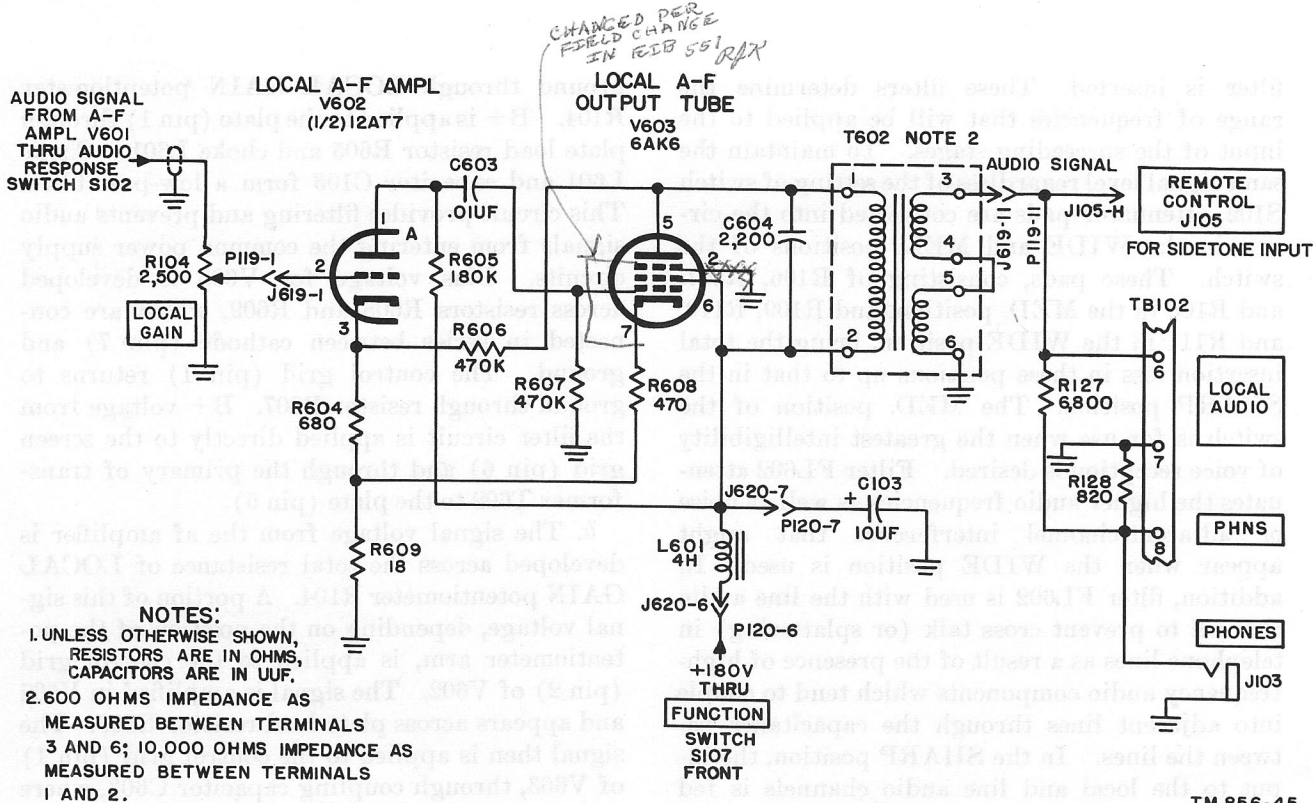

Figure 46. Local audio channel, schematic diagram.

are incorporated in the local audio channel to obtain the required output impedance. The negative voltage feedback loop consists of resistors R606, R604, and R609. This circuit reduces the internal impedance of the amplifier and the overall gain, and results in improved stability. Harmonic distortion, noise, and hum also are reduced, since they are fed back with the original signal and reduced in amplitude in proportion to the reduced gain. Negative current feedback is produced by unbypassed resistors R608 and R609 in the cathode circuit of V603 and by R604 in the cathode circuit of the local af amplifier. This negative current feedback increases the internal impedance of the amplifier. The ratio between the amounts of the two types of feedback is adjusted to set the internal impedance of the amplifier to 600 ohms. A small amount of positive voltage feedback is applied to the cathode of the local af amplifier R604, which is connected to the junction of R608 and R609. This eliminates the negative feedback at the cathode that is introduced through resistor R604. The gain of the local af amplifier is therefore equivalent to that produced in a similar amplifier stage employing a cathode bypass capacitor and no negative current feedback.

## 72. Line Audio Channel

(fig. 47)

The line audio channel is similar to the local audio channel, which is explained in paragraph 71; however, it is designed to feed a balanced line having an impedance of 600 ohms, and it has provisions for monitoring the output level of the channel with LINE LEVEL meter M101.

a. Bias voltage for the line af amplifier is developed across resistors R628 and R633, which are connected in series between the cathode (pin 8) and ground. The control grid (pin 7) is connected to ground through LINE GAIN potentiometer R103. B+ voltage is applied to the plate (pin 6) through plate load resistor R629 and decoupling resistor R634. R634 and C609 form a decoupling circuit. The B+ voltage is obtained from the power supply through choke L601. A low-pass filter consisting of filter choke L601 and capacitor C103 prevents audio signals from entering the common power supply circuits. Bias voltage for V604 is developed across resistors R632 and R633, which are connected in series between the cathode (pin 7) and ground. The control grid (pin 1) is connected to ground through resistor R631. B+ voltage is applied directly to

the screen grid (pin 6) and through the primary of transformer T603 to the plate (pin 5).

b. The signal path through line af amplifier and line af output tube is identical with the signal path through local af amplifiers. The three types of feed-back circuits explained in paragraph 71 are also applicable to section B of V602 and V604. The output circuit of the line audio channel differs from that of the local audio channel because terminals 4 and 5 of transformer T603 are connected directly to terminals 11 and 12 of TB101. A jumper is normally connected between these terminals of TB101 except under conditions where a balancing network is required to correct to 600 ohms the terminal impedance of a line connected to terminals 10 and 13. The end terminals (3 and 6) of the transformer are connected to an H-type attenuator, consisting of resistors R112 through R116. The attenuator reduces the output from approximately 250 milliwatts (mw) so that a maximum of 10 mw (+10 dbm) of af power is supplied to a 600-ohm balanced line connected to terminals 10 and 13 of TB101, as well as to terminals A and J of REMOTE CONTROL receptacle J105. (The H-type attenuator is used to reduce the power level by 14 db to permit the use of a meter having a 4-db sensitivity and still achieve a -10-dbm output level.) Output is applied to the remote-control receptacle only when BREAK IN switch S106 is in the OFF position. LINE LEVEL meter M101 is connected across the output-transformer secondary to indicate the level of the signal being applied to the balanced line. This meter is calibrated in vu which are based on a zero reference level pure sine wave of 1 mw into 600 ohms or 0 dbm. For example, a reading of -20 vu or +3 vu would be equivalent to -20 dbm or +3 dbm. The face of the meter has two scales: the upper scale is calibrated to read directly in vu when LINE METER switch S101 is set to 0 vu; the lower scale is calibrated from 0 to 100 ending at a point opposite 0 vu on the upper scale. When the output of the receiver is fed into a telephone line, the meter circuit is used to show the line input level. Meter M101 has an impedance of 3,900 ohms. Resistor R101 is connected in series with M101 to match its impedance to the amplifier and to enable the meter to follow the audio amplitude changes. To change the range of the meter, switch S101 selects either of two pads or permits direct connection to the meter.

For the -10 vu range, the connection is direct; for the 0-vu range, a pad consisting of R117, R118 and R119 is used; and for the +10 vu range a pad consisting of R120, R121, and R122 is used. Pads are used as range multipliers and to maintain the impedance match. A fourth position of the switch, OFF, disconnects the meter from the circuit and substitutes R102 in its place to maintain the impedance match required across the secondary winding of T603.

Figure 47. Line audio channel, schematic diagram.

(Contained in separate envelope)

### 73. Squelch Circuit

(fig. 48)

The squelch circuit utilizes one-half of a 12AU7 dual-triode tube (V601) which is connected as a dc amplifier. The squelch circuit eliminates noise signals in the output of the audio amplifiers when signals are not being received or when the signal level of the desired carrier is too low for useful reception.

a. Fixed cathode bias is developed across resistor R612, which is part of a voltage-divider circuit consisting of resistors R612 and R613 connected between B+ and ground. B+ voltage is only supplied to the plate (pin 1) of V601 through the coil of relay K601 and to the voltage divider when the FUNCTION switch S107 is in the SQUELCH position.

b. In the absence of a carrier-frequency signal, or when a weak carrier-frequency signal is being received, no negative bias is applied to the grid (pin 2) of V601. The tube conducts and plate current flows through the coil of relay K601 energizing the relay and closing contacts 1 and 2. Contact 2 is connected to terminal 3 of T601, and contact 1 is connected to ground; therefore, when these contacts close, the secondary winding of transformer T601 is shorted, and the audio amplifiers are disabled. When a carrier-frequency signal of sufficient level is received, the voltage across the diode load (resistors R539 and R540) becomes more negative. This negative voltage, which is applied to the control grid (pin 2) of V601 through resistor R610, causes the plate current to decrease. When the plate current decreases, relay K601 is deenergized and contacts 1 and 2 open; the ground is thereby removed from terminal 3 of transformer T601 and the received signal appears in the output of the audio amplifiers. By-

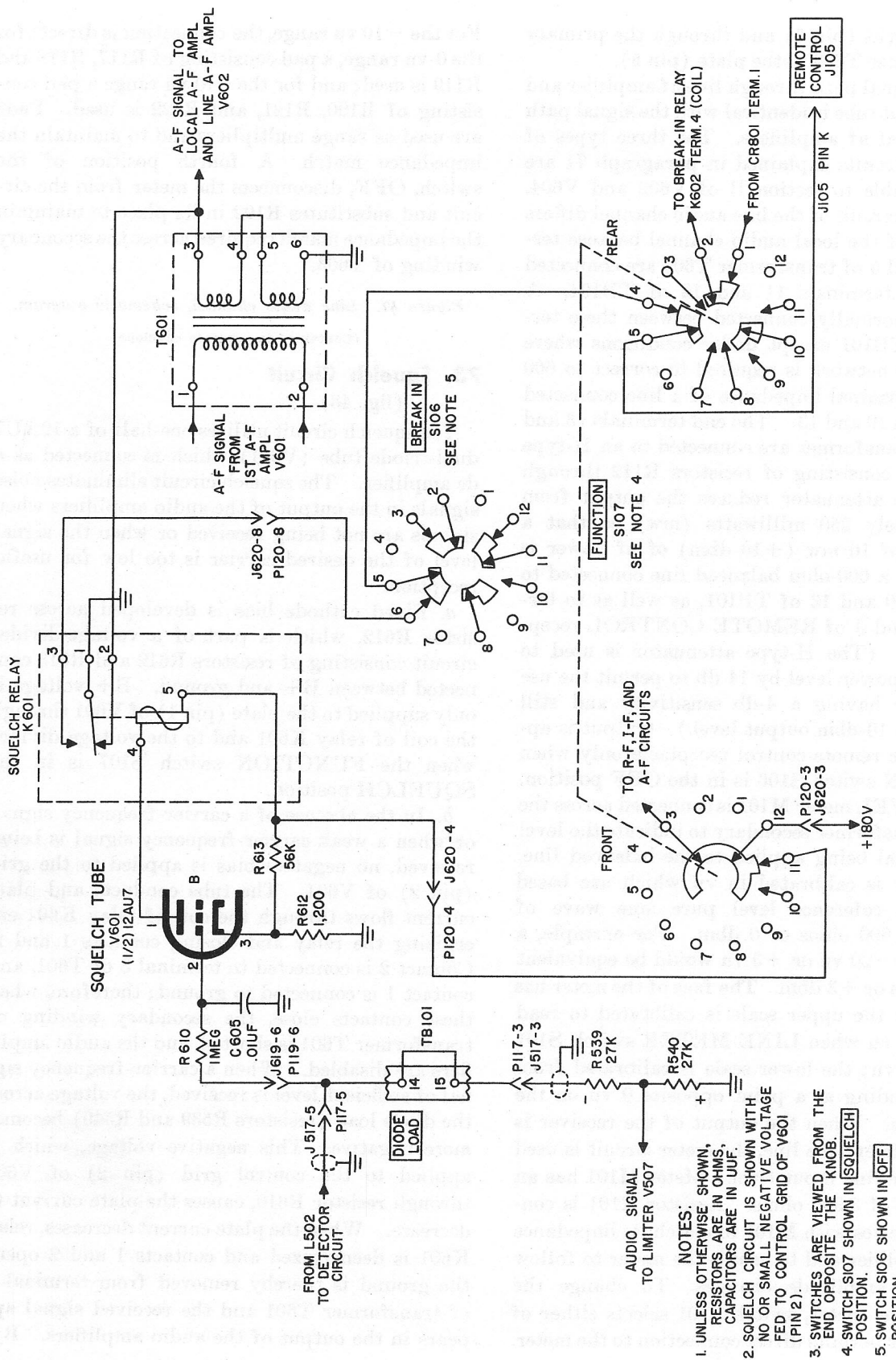

Figure 48. Squelch circuit, schematic diagram.

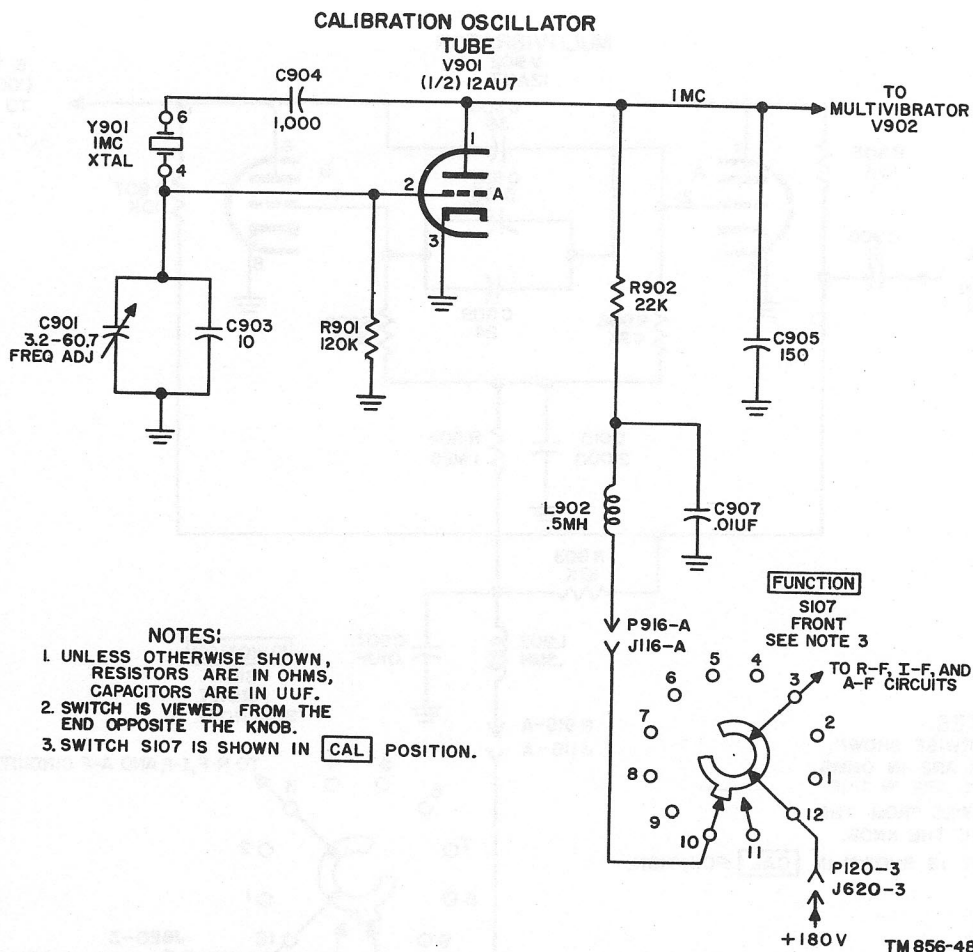

Figure 49. Calibration oscillator, schematic diagram.

pass capacitor C605, between the grid (pin 2) of V601B and ground, prevents chattering of the relay which might be caused by audio frequency signals. The position of the RF GAIN control determines the level to which the incoming signal must rise before it can operate the relay circuit.

c. A carrier-control circuit also is incorporated in relay K601. When an adequate signal is received, relay K601 is deenergized and contact 1 makes with contact 3. With FUNCTION switch S107 and BREAK IN switch S106 set to SQUELCH and OFF positions, respectively, the closing of these contacts will complete to ground the carrier-control circuit of a transmitter through pin K of REMOTE CONTROL receptacle J105.

## 74. Calibration Oscillator

(fig. 49)

The function of the calibration oscillator and the associated circuits is to provide a secondary

standard frequency in 100-kc steps in the frequency range .5 to 32 mc for use in calibrating Radio Receiver R-390/URR. The calibration oscillator, one-half of V901, supplies a crystal controlled 1-mc signal to synchronize multivibrator V902.

a. Resistor R901 provides dc bias to the control grid (pin 2) and limits crystal current. B+ is applied to the plate (pin 1) through series-dropping resistor R902, and coil L902, when the FUNCTION switch (S107) is set to the CAL position. L902 and C907 form a low-pass filter to isolate the rf circuits from the power supply.

b. The calibration oscillator uses one-half of a miniature dual-triode tube (type 12AU7, V901) in a Pierce oscillator circuit. The crystal (Y901), connected between the control grid and the plate circuit, takes the place of a conventional tuned circuit. Dc plate voltage is blocked from the crystal by capacitor C904. Capacitor C905 is



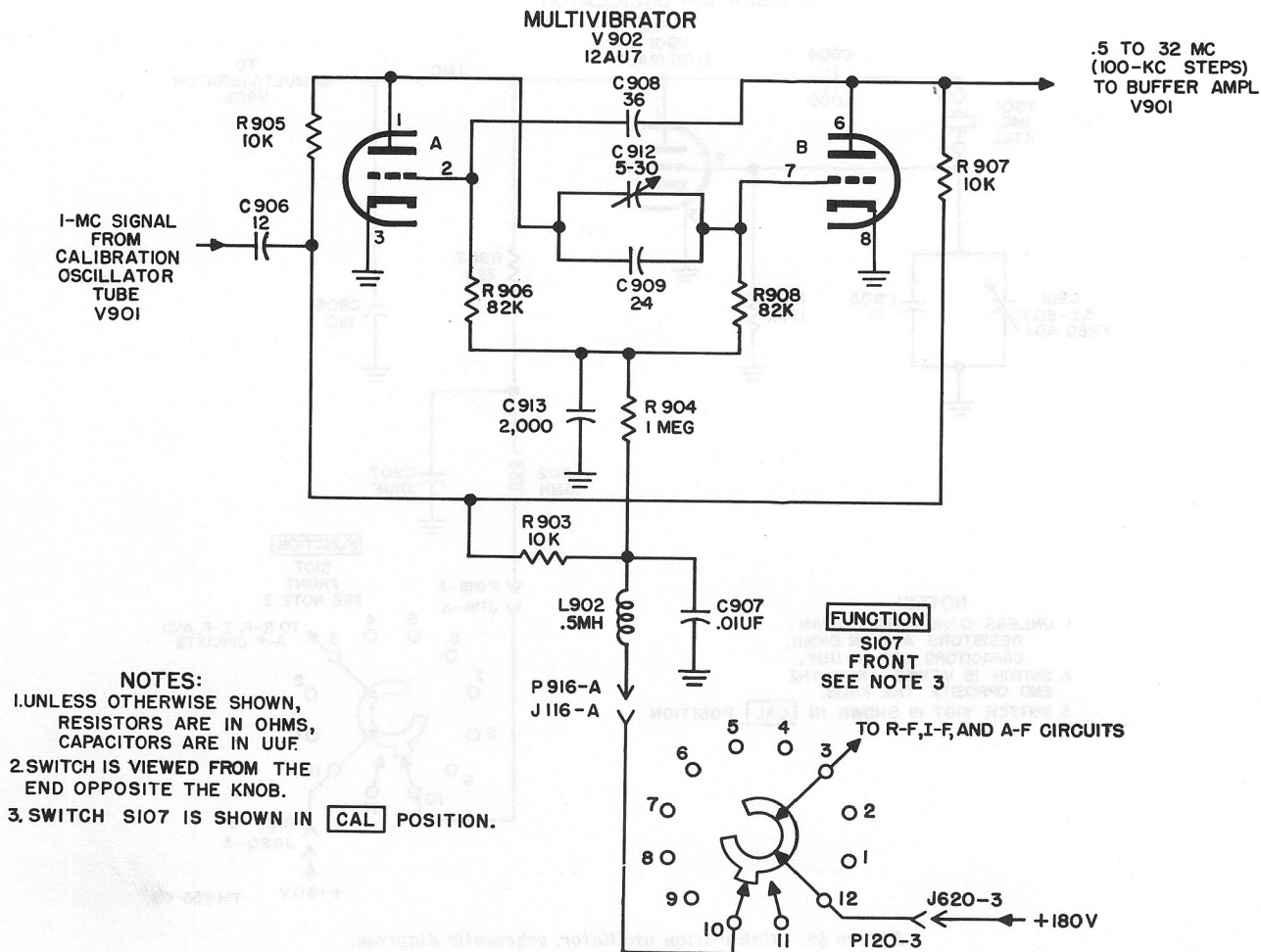

TM 856-49

Figure 50. Multivibrator, schematic diagram.

used to provide the proper amount of feedback from the plate to the cathode. The amount of feedback is fixed by the voltage-divider action of capacitor C905 and parallel capacitors C901 and C903. Frequency adjustment capacitor C901 is variable and it permits adjustment of the resonant frequency over a small range. Its use is described in paragraph 128.

## 75. Multivibrator V902

(fig. 50)

The 1-mc signal from the calibration oscillator is used to synchronize the multivibrator at 100 kc. Since the multivibrator output (a square wave) is composed of a large number of harmonics, it is capable of supplying all the calibrating signals required to cover the frequency range .5 to 32 mc.

a. Initial positive bias for the control grids (pins 2 and 7) is supplied from B+ through filter

choke L902, voltage-dropping resistor R904, and grid resistors R906 and R908. Choke L902 and resistor R904 are bypassed by C907 and C913, respectively, to provide a low-impedance path to ground for rf signals. A positive voltage, greater than that applied to the grids, is applied to the plates (pins 1 and 6) through resistors R903, R905, and R907. All B+ voltages are applied through FUNCTION switch S107, front, when set to the CAL position.

b. The output of the calibration oscillator is coupled by capacitor C906 to the multivibrator, a free-running relaxation-type oscillator employing a miniature dual-triode tube, type 12AU7. Oscillation is sustained by the feedback from the plate of one tube section to the grid of the other tube section. The free-running frequency prior to synchronization by the crystal oscillator is determined by the time constants of R906 and C908 for

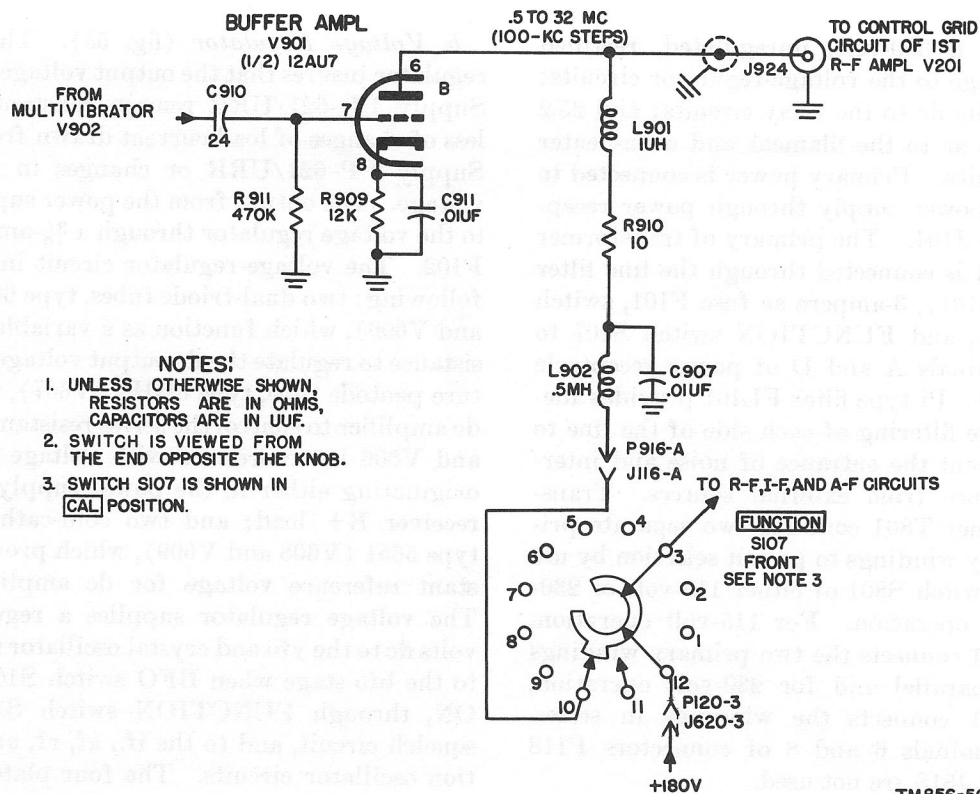

Figure 51. Buffer amplifier, schematic diagram.

tube section A, and of R908, C909, and C912 for tube section B. Grid coupling capacitors C908, C909, and C912 are not of the same value, since compensation must be made for the grid input impedance of buffer amplifier V901, which is effectively across one tube section of the multivibrator. C912, being adjustable, permits synchronization at 100 kc. This adjustment is made and set permanently by the manufacturer, and no readjustment will be required.

## 76. Buffer Amplifier

(fig. 51)

The buffer amplifier is a triode section of a dual-triode tube, type 12AU7. The buffer amplifier amplifies and distorts the output of the multivibrator and isolates the multivibrator from the first rf amplifier.

a. Resistor R911 (connected to pin 7) serves as the dc-grid return, and cathode resistor R909 (connected to pin 8) maintains a constant bias on the control grid. Cathode bypass capacitor C911 offers a low-impedance path to ground for rf signals. B+ is applied to the plate (pin 6) through choke L902, resistor R910, and choke L901. Choke

L902 and capacitor C907 form a plate circuit decoupling network. To increase the higher harmonics in the vicinity of 25 mc and thus to flatten the overall frequency response, L901 and R910 form a low-Q resonant circuit with the output capacitance of V901.

b. The 100-kc signal from the multivibrator is applied through capacitor C910 to the buffer-amplifier control grid. The output from the plate (pin 6) is applied to the input circuit of the first rf amplifier, V201.

## 77. Power Circuits

The power circuits provide regulated B+ voltage to all stages, heater voltages for the filaments of all tubes, dc voltage to operate relay circuits, and ac voltage for the crystal-oven heater circuits. The power supply consists of two sections or components, Power Supply PP-621/URR and the voltage regulator. Operation of the FUNCTION S107 switch (S107) connects the ac power input to the power supply in all positions except OFF.

a. Power Supply PP-621/URR (fig. 52).

(1) The power supply operates from either 115 or 230 volts, 48 to 62 cycles. It sup-

plies a 300-volt, unregulated, rectified voltage to the voltage-regulator circuits; 6 volts dc to the relay circuits; and 25.2 volts ac to the filament and oven-heater circuits. Primary power is connected to the power supply through power receptacle J104. The primary of transformer T801 is connected through the line filter (FL101), 3-ampere ac fuse F101, switch S801, and FUNCTION switch S107 to terminals A and D of power receptacle J104. Pi-type filter FL101 provides adequate filtering of each side of the line to prevent the entrance of noise and interference from external sources. Transformer T801 contains two separate primary windings to permit selection by use of switch S801 of either 115-volt or 230-volt operation. For 115-volt operation, S801 connects the two primary windings in parallel and for 230-volt operation, S801 connects the windings in series. Terminals 6 and 8 of connectors P118 and J818 are not used.

- (2) The ends of the high voltage secondary (terminals 5 and 7) of transformer T801 are connected to the plates (pins 1 and 6) of rectifiers V801 and V802. The center tap of transformer T801 (terminal 6) is grounded. The tubes, V801 and V802, are connected as diodes in a full-wave rectifier circuit. Each cathode (pins 3 and 8) has a protective resistor between it and the common connection at J818, terminal 5. These resistors (R801, R802, R803 and R804) limit the maximum current of each diode. The low voltage secondary (terminals 8 and 10) of T801 supplies 25.2 volts to the rectifier tube heaters, all remaining heaters, dial lamps, and oven heater circuits. A tap (terminal 9) on this winding provides 12 volts to a dry disk rectifier (CR801), the dc output of which supplies 6 volts for operation of the antenna relay K101 and the break-in relay K602 through the FUNCTION and BREAK IN switches. The high voltage dc output from the power supply is filtered by input capacitor C101 before being applied to the voltage regulator circuits.

*b. Voltage Regulator* (fig. 53). The voltage regulator insures that the output voltage of Power Supply PP-621/URR remain constant, regardless of changes of load current drawn from Power Supply PP-621/URR or changes in the input voltage. The output from the power supply is fed to the voltage regulator through a  $\frac{3}{8}$ -ampere fuse, F102. The voltage-regulator circuit includes the following: two dual-triode tubes, type 6082 (V605 and V606), which function as a variable series resistance to regulate the dc output voltage; a miniature pentode tube, type 6BH6 (V607), which is a dc amplifier to control the series resistance of V605 and V606 in accordance with voltage variations originating either in the power supply or in the receiver B+ load; and two cold-cathode tubes, type 5651 (V608 and V609), which provide a constant reference voltage for dc amplifier V607. The voltage regulator supplies a regulated 180 volts dc to the vfo and crystal oscillator subchassis, to the bfo stage when BFO switch S103 is set to ON, through FUNCTION switch S107 to the squelch circuit, and to the if., af, rf, and calibration oscillator circuits. The four plates of V605 and V606 (pins 2 and 5) are all tied together and connected directly to the unregulated dc voltage; the four cathodes (pins 3 and 6) are connected in parallel by four resistors (R619 through R622) to balance the distribution of load current. The voltage appearing at the cathodes is determined by the voltage drop across the tube resistance, which is controlled by the bias appearing on the four parallel-connected grids. If either the unregulated voltage or the regulated voltage changes, V607 will convert the change into a comparative bias-voltage change, and the resistance of the series voltage regulators will change in a direction to correct the initial change. A series circuit consisting of voltage reference tubes V608 and V609 and resistors R625 and R626 is connected across the voltage-regulated output circuit. Resistor R627 across V608 insures that both reference tubes receive proper starting voltage. A characteristic of these tubes is that the voltage drop across their terminals remains nearly constant in spite of changes in current. Therefore, any voltage variation that takes place across the series circuit appears across R625 and R626. The drop across R626 is applied through resistor R624 to the control grid (pin 1) of V607, and amplified variations are produced across plate load potentiometer R614 and resistor R615. Resistor R618, which is by-

passed for af by C606, provides a fixed positive bias to the cathode (pin 2). These amplified voltage variations then are applied to the parallel-connected control grids of V605 and V606. Capacitor C607 bypasses transient pulses appearing in the grid circuit of voltage regulators V605 and V606. The circuit operates in the following manner: If the dc voltage at the control grid of V607 increases, because of an increase of current in the load, the voltage on the plate circuit will drop; this produces a less positive voltage on the parallel-connected grids of V605 and V606, which increases the resistance of the tubes and, consequently, the voltage drop across the tubes. Thus the output voltage from the cathode circuit of V605 and V606 will decrease by an amount equal to the positive bias fed to the dc amplifier control grid. The reverse action will take place when the current in the load decreases. The action is automatic and produces a nearly constant output voltage. In addition to controlling voltage variations caused by changes in load, the voltage regulator serves to eliminate ripple and hum components that are not removed completely by the RC filter, and to eliminate variations caused by line-voltage changes. Compensation for 120-cps ripple is provided through capacitor C608, which applies the ripple voltage to the control grid (pin 1) of the dc amplifier. The screen grid (pin 6) is connected through a voltage divider (resistors R616 and R617) to the unregulated voltage ahead of the regulator tubes. Therefore the screen-grid voltage varies in phase with the control-grid voltage of the dc amplifier. This increases the effectiveness of the amplifier in maintaining constant output voltage. R614, HUM BAL control, is an adjustment for presetting the amount of the ripple voltage fed back to the control grids of V605 and V606 to minimize the hum in the output. Capacitor C606 adjusts the phase of the hum components of the cathode voltage to produce more complete hum cancellation in the output.

*c. Filament and Oven Heater Circuits (fig. 54).* Filament voltages of 6.3, 12.6, and 25.2 volts are required for the tubes in the receiver. Dial lamps I 101 and I 102 and filaments that require 25.2 volts are connected in parallel with the filament winding. The filaments requiring 6.3 or 12.6 volts are connected in series circuits. To prevent inter-stage coupling of high-frequency signals through the filament circuits, the following capacitor and choke coil combinations are used: L242 and C326;

L243 and C327; L244, C328, and C329; L245, C330, and C331; L247, C332, and C340; L403, C437, and C410; L404 and C412; L405, C413, and C436; and L706, C712, and C713. Limiting resistor R411 limits the voltage across V401, V402, and V201 to 18 volts. To maintain constant heater voltage and thus stabilize the operation of the vfo tube (V701) and the bfo tube (V508), ballast tube (RT512) is connected in series with the filaments of V701 and V508. When the OVENS switch S108 is set to ON, 25.2 volts is applied to the crystal oscillator oven and the vfo oven; 25.2 volts is applied to the calibration oscillator oven at all times. The crystal oscillator oven (HR401), the vfo oven (HR701), and the calibration oscillator oven (HR901) serve to further improve the stability of the vfo, the calibration oscillator, and the crystal oscillator circuits. The ovens are thermostatically controlled by switches S405 and S701, in the crystal oscillator and vfo oven circuits, respectively, and by the unmarked switch in the calibration oscillator oven circuit. To prevent electrical interference caused by arcing at the contacts of the thermostatic switches, capacitors C434, C435, C710, C711, C902 and coil L705 are connected in the oven circuits. Resistor R635 has been added to the audio subchassis in series with the filament circuit of tubes V601 and V602. This resistor reduces the filament current for these tubes, which in turn reduces the hum in the audio subchassis.

*Figure 52. Power Supply PP-621/URR, schematic diagram.*

(Contained in separate envelope)

*Figure 54. Filament and oven heater circuits, schematic diagram.*

(Contained in separate envelope)

## 78. Function Switch S107

*a.* The FUNCTION switch performs simple switching operations which affect the entire operation of Radio Receiver R-390/URR. Each mode of operation and each stage is affected by the position of the segments of the front and rear sections of this switch. A thorough understanding of the switch is essential for successful troubleshooting and maintenance.

*b.* Figure 55 shows the six positions of the FUNCTION switch. For clarification of its operation, only those circuits which are closed by

the switch segments are identified. For example, although a jumper connects terminals 8 and 10 together and to ground, a ground connection is only shown to terminal 10 in the STAND BY position, since the segment does not contact terminal 8 in this position. The table below shows the circuits affected in each of the positions of the

switch as related to the control knob indication. The primary power is applied to Power Supply PP-621/URR through a cam-operated switch section at the front of S107 in all positions except OFF. The following chart shows the completed contacts and circuits for the six positions of FUNCTION switch S107.

Position	Switch contacts shorted		Circuits
	Front	Rear	
OFF-----	None-----	None-----	Primary power is disconnected from the receiver (fig. 52).
STAND BY-----	None-----	9 to 10-----	Primary power is applied to the receiver (fig. 52). Terminal 2 of CR801 is grounded, applying 6 volts dc to antenna relay K101 which grounds the antenna input at J107 and J108. +180 volts dc is removed from the rf, if., and af stages.
AGC-----	12 to 3-----	1 to 2-----	+180 volts dc is applied to the rf, if., and af stages. Agc voltage at contact 7 of S107 is not grounded. Ground is removed from terminal 2 of CR801 removing energizing voltage to antenna relay K101. Contacts 1 and 2 of S107 connect terminal 1 of CR801 to terminal 4 (coil) of break-in relay K602. Break-in operation is made available (par. 79).
MGC-----	12 to 3-----	2 to 3----- 7 to 8-----	The conditions for MGC are the same as for AGC except the agc bus is grounded through contact 7.
CAL-----	12 to 3----- 12 to 10	8 to 9-----	+180 volts dc is applied to the rf, if., af, and calibration oscillator stages. Terminal 2 of CR801 is grounded, applying 6 volts dc to antenna relay K101 which grounds the antenna input at J107 and J108.
SQUELCH-----	12 to 3----- 12 to 11-----	1 to 2----- 4 to 5	The conditions for SQUELCH are the same as for AGC except +180 volts dc is applied to squelch tube V601. Carrier control circuit is made available (par. 79).

## 79. Control Circuits

(fig. 56)

a. When using Radio Receiver R-390/URR in connection with a transmitter, it is necessary to disable certain receiver circuits during transmission to prevent damage and to silence the receiver. When FUNCTION switch S107 is set to STAND BY, segment 2 is across terminals 9 and 10 and ground is applied to terminal 2 of rectifier CR801; therefore antenna grounding relay K101 is energized. The movable contacts of this relay are connected to ground, and the contacts short-circuit the antenna input at receptacle J107 or J108. No rf energy can enter the input circuits of Radio Receiver R-390/URR. When FUNCTION switch S107 is at CAL position the rf input is shorted to ground in the same manner as described above, except that segment 1 is across terminals 9 and 8. This prevents rf signals from entering Radio Receiver R-390/URR to produce false beat notes with the output of the calibration

oscillator. When FUNCTION switch S107 is at AGC, MGC, or SQUELCH, the coil of break-in relay K602 is in parallel with the coil of antenna grounding relay K101. By applying a ground connection, by means of auxiliary equipment, to terminals 9 of TB101 or B of REMOTE CONTROL receptacle J105 and by turning BREAK IN switch S106 to ON, segment 3 of S106 is across terminals 8 and 10, and the antenna relay K101 and break-in relay K602 are energized. The antenna input and the af amplifier output are short-circuited to ground. Thus Radio Receiver R-390/URR is disabled during the operation of a local transmitter if it is connected for remote operation. With the BREAK IN switch in the OFF position, line audio output is applied to terminals A and J of REMOTE CONTROL receptacle J105 to permit remote net operation. To permit carrier control operation, FUNCTION switch S107 must be set to SQUELCH and BREAK IN switch to OFF. The carrier control

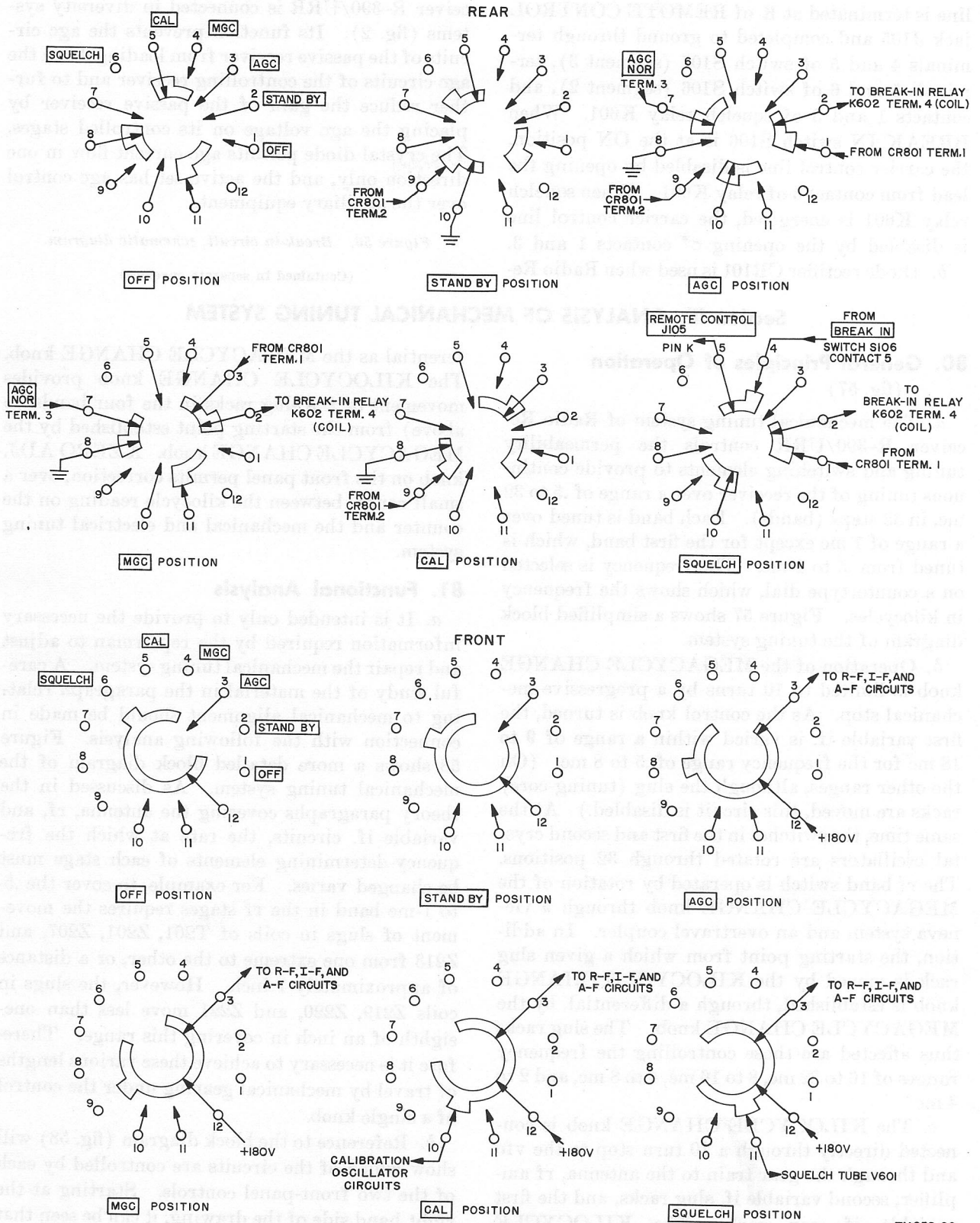

Figure 55. FUNCTION switch S107, schematic diagram.

line is terminated at K of REMOTE CONTROL jack J105 and completed to ground through terminals 4 and 5 of switch S107 (segment 3), terminals 5 and 6 of switch S106 (segment 2), and contacts 1 and 3 of squelch relay K601. When BREAK IN switch S106 is at the ON position, the carrier control line is disabled by opening the lead from contact 3 of relay K601. When squelch relay K601 is energized, the carrier control line is disabled by the opening of contacts 1 and 3.

b. Diode rectifier CR101 is used when Radio Re-

ceiver R-390/URR is connected in diversity systems (fig. 2). Its function prevents the agc circuits of the passive receiver from loading down the agc circuits of the controlling receiver and to further reduce the gain of the passive receiver by placing the agc voltage on its controlled stages. The crystal diode permits agc current flow in one direction only, and the active set has agc control over the auxiliary equipment.

Figure 56. Break-in circuit, schematic diagram.

(Contained in separate envelope)

### Section III. ANALYSIS OF MECHANICAL TUNING SYSTEM

#### 80. General Principles of Operation

(fig. 57)

a. The mechanical tuning system of Radio Receiver R-390/URR controls the permeability tuning and switching elements to provide continuous tuning of the receiver over a range of .5 to 32 mc, in 32 steps (bands). Each band is tuned over a range of 1 mc except for the first band, which is tuned from .5 to 1 mc. The frequency is selected on a countertype dial, which shows the frequency in kilocycles. Figure 57 shows a simplified block diagram of the tuning system.

b. Operation of the MEGACYCLE CHANGE knob is limited to 10 turns by a progressive mechanical stop. As the control knob is turned, the first variable if. is varied within a range of 9 to 18 mc for the frequency range of .5 to 8 mc. (On the other ranges, although the slug (tuning-core) racks are moved, this circuit is disabled.) At the same time, the switches in the first and second crystal oscillators are rotated through 32 positions. The rf band switch is operated by rotation of the MEGACYCLE CHANGE knob through a Geneva system and an overtravel coupler. In addition, the starting point from which a given slug rack is moved by the KILOCYCLE CHANGE knob is established, through a differential, by the MEGACYCLE CHANGE knob. The slug racks thus affected are those controlling the frequency ranges of 16 to 32 mc, 8 to 16 mc, 4 to 8 mc, and 2 to 4 mc.

c. The KILOCYCLE CHANGE knob is connected directly through a 10 turn stop to the vfo and through the gear train to the antenna, rf amplifier, second variable if. slug racks, and the first variable if. can rack. The KILOCYCLE CHANGE knob also is connected to the same dif-

ferential as the MEGACYCLE CHANGE knob. The KILOCYCLE CHANGE knob provides movement of the slug racks in the four bands (b above) from the starting point established by the MEGACYCLE CHANGE knob. A ZERO ADJ. knob on the front panel permits correction, over a small range, between the kilocycle reading on the counter and the mechanical and electrical tuning system.

#### 81. Functional Analysis

a. It is intended only to provide the necessary information required by the repairman to adjust and repair the mechanical tuning system. A careful study of the material in the paragraph relating to mechanical alignment should be made in connection with the following analysis. Figure 58 shows a more detailed block diagram of the mechanical tuning system. As discussed in the theory paragraphs covering the antenna, rf, and variable if. circuits, the rate at which the frequency-determining elements of each stage must be changed varies. For example, to cover the .5- to 1-mc band in the rf stages requires the movement of slugs in coils of T201, Z201, Z207, and Z213 from one extreme to the other, or a distance of approximately 1 inch. However, the slugs in coils Z219, Z220, and Z221 move less than one-eighth of an inch in covering this range. Therefore it is necessary to achieve these various lengths of travel by mechanical gearing under the control of a single knob.

b. Reference to the block diagram (fig. 58) will show which of the circuits are controlled by each of the two front-panel controls. Starting at the right-hand side of the drawing, it can be seen that the KILOCYCLE CHANGE control, working

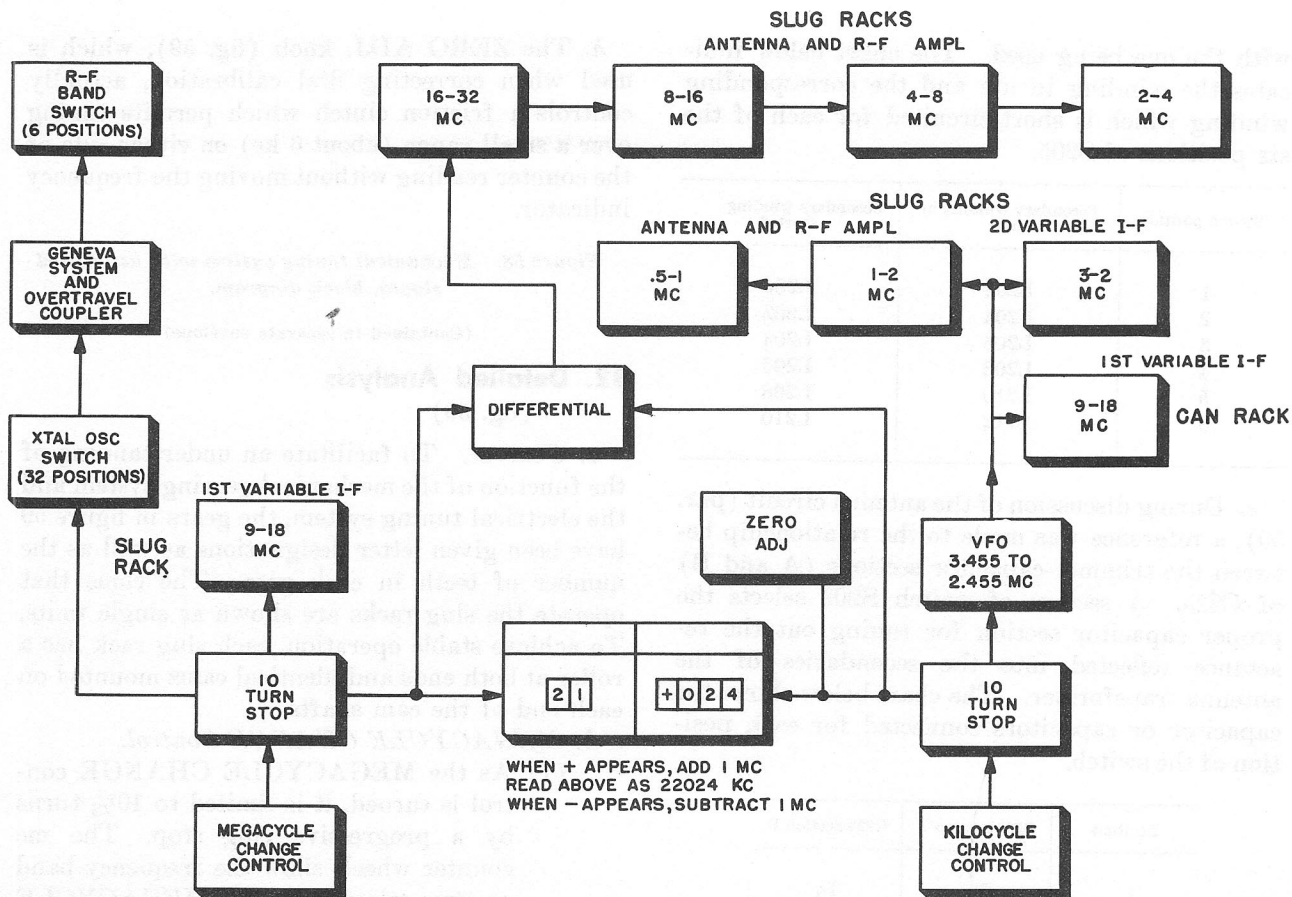

TM 856-56

Figure 57. Mechanical tuning system, block diagram.

through the 10-turn stop, varies the position of the variable frequency-oscillator slug, the second variable if. slug rack, the first variable if. can rack, the rf slug rack covering the .5- to 1-mc range, and the rf slug rack covering the 1- and 2-mc range.

c. The MEGACYCLE CHANGE control, through a 10-turn stop and the Geneva system and overtravel coupler, varies the positions of switches S201 through S210. This control also selects the proper crystal frequency for the first and second crystal oscillator stages, by operating the 32-position switch through a system of gears. The MEGACYCLE CHANGE control rotates switches S401 through S404 in the first and second crystal oscillators through 32 steps of frequency coverage. These 32 steps are covered by only 6 transformers or coils, for each stage. Since each set of coils has a frequency ratio of 2 to 1, it is necessary to have the positions of the switches change only 6 times for 32 steps of frequency cov-

erage. This is accomplished by a lost-motion coupler with a few teeth approximately geometrically spaced around the perimeter of the gear. A driven gear associated with this gear will rotate only when it is engaged by one of the teeth on the lost-motion gear. The MEGACYCLE CHANGE control also sets (through the differential) the starting point of the slug racks of the last four bands. From this starting point, the KILOCYCLE CHANGE control moves (through the same differential) these slug racks to cover frequency range of the KILOCYCLE CHANGE control. The first variable if. cans are mounted on a rack which is driven by the KILOCYCLE CHANGE control, as required, to keep these circuits in alignment during tuning.

d. The MEGACYCLE CHANGE control drives switch S205. The front section of the switch is used to short-circuit the secondary winding of the unused adjacent antenna transformer (next lower in frequency) to prevent interaction



with the one being used. The chart below indicates the winding in use and the corresponding winding which is short-circuited for each of the six positions of S205.

Switch position	Secondary winding in use	Secondary winding shorted
1	L202	L206
2	L204	L202
3	L206	L204
4	L208	L206
5	L210	L208
6	L212	L210

e. During discussion of the antenna circuit (par. 50), a reference was made to the relationship between the trimmer-capacitor sections (A and B) of C225. A section of switch S203 selects the proper capacitor section for tuning out the reactance reflected into the secondaries of the antenna transformer. The chart below shows the capacitor or capacitors connected for each position of the switch.

Position	C225 Section A	C225 Section B
1	In	In
2	In	In
3	In	Out
4	In	Out
5	Out	In
6	Out	In

f. When inspecting the various gears employed, note that each gear in the Geneva system actually is composed of two gears which are adjacent to each other and are loaded by a spring in opposite directions. This is done to achieve a constant tension at the point where the gear is driven or at which it drives an associated gear. In this manner, lost motion, or backlash, as a result of play between the gear teeth, is prevented. All gears and cams employed are precision-cut, and are designed to give many years of trouble-free service.

g. The calibration oscillator is not a part of the tuning system. It provides calibration signals which are used in correcting small errors in tuning made by the mechanical tuning system. By the use of the proper calibration signal and the ZERO ADJ. control, the receiver counter reading can be made to coincide with the frequency of the received signal.

h. The ZERO ADJ. knob (fig. 59), which is used when correcting dial calibration, actually controls a friction clutch which permits tuning over a small range (about 6 kc) on either side of the counter reading without moving the frequency indicator.

Figure 58. Mechanical tuning system with associated stages, block diagram.

(Contained in separate envelope)

## 82. Detailed Analysis (fig. 59)

a. *General.* To facilitate an understanding of the function of the mechanical gearing system and the electrical tuning system, the gears in figure 59 have been given letter designations as well as the number of teeth in each gear. The cams that operate the slug racks are shown as single units. To achieve stable operation, each slug rack has a roller at both ends and identical cams mounted on each end of the cam shafts.

b. *MEGACYCLE CHANGE Control.*

- (1) As the MEGACYCLE CHANGE control is turned, it is limited to  $10\frac{1}{2}$  turns by a progressive ring stop. The mc counter wheels show the frequency band or step selected by the MEGACYCLE CHANGE control. As the control is rotated, the wheels are driven through gears (A), (B), (C), (D), (E), (F), (RR), (SS), (TT), (UU), (VV), (WW), and (XX).
- (2) The control operates the first variable if slug-rack cam through gears (A), (B), (C), (D), (E), (F), and (G). At the same time, the 32 position crystal oscillator switches are operated by the control through gears (A), (B), (C), (D), (E), an Oldham coupler, and gears (H) and (J). The Oldham coupler is used to correct slight misalignment between the ends of the shafts which are mechanically coupled at the crystal oscillator sub-chassis.
- (3) The 6-position rf band switches are also operated by the MEGACYCLE CHANGE control through gears (A), (B), (C), (D), (E), (K), the Geneva system (L), lost motion gear (GGG), gears (M), (N), and (P). The Geneva

system provides an intermittent motion so that the switch is turned to only one of its six positions. The gear (L) rotates continuously as the control is turned. However, the gears (M), (N) and (P) are driven only during the part of the rotation of the gear (L) when the teeth of lost motion gear (GGG) engage the teeth of the gear (M).

(4) The 2-4 mc, 4-8 mc, 8-16 mc, and 16-32 mc rf slug racks are moved by both the MEGACYCLE CHANGE and the KILOCYCLE CHANGE controls through a differential gear system. The 2-4 mc rf slug rack cam is operated by the MEGACYCLE CHANGE control through gears (A), (B), (Q), (R), (S), and (T). The 4-8 mc rf slug rack cam is operated through gears (A), (B), (Q), (R), (S), (T), (U), and (V). The 8-16 mc rf slug rack cam is rotated through gears (A), (B), (Q), (R), (S), (T), (U), (V), (W), and (X). The 16-32 mc rf slug rack cam is turned through gears (A), (B), (Q), (R), (S), (T), (U), (V), (W), (X), (Y), and (Z).

(5) In each of the steps of frequency coverage, it is necessary to have an exact reference or stopping position for the circuit elements controlled by the MEGACYCLE CHANGE. This is accomplished by the mc change detent. A disk with three notches spaced equally around its edge is rotated by gears (B) and (A) when the control is operated. An L-shaped bracket made of spring material presses against the disk and produces an effective stop at each notch.

*c. KILOCYCLE CHANGE Control.*

(1) The KILOCYCLE CHANGE control is limited to  $10\frac{1}{2}$  turns by a progressive ring stop. The kc counter wheels show the frequency selected by the KILOCYCLE CHANGE control. To permit overlapping of each band selected, the frequency range of this control is greater than 1 mc. As the KILOCYCLE CHANGE control is rotated, the wheels are driven through gears (AA), (YY), (ZZ), (AAA), (BBB), and (CCC).

(2) The vfo tuning unit is connected through an Oldham coupler to the KILOCYCLE CHANGE control.

(3) As the KILOCYCLE CHANGE control is rotated, the second variable if slug rack cam and the first variable if can rack cam are operated through gears (BB), (CC), (DD), (EE), and (FF).

(4) The 2-4 mc, 4-8 mc, 8-16 mc, and 16-32 mc rf slug racks are moved by the KILOCYCLE CHANGE control through a differential gear system. The rf slug rack cams mentioned above are operated through the same gears mentioned in b(4) above except for gears (A) and (B). These two gears are replaced by gears (BB), (CC), (GG), (HH), (PP), and (QQ).

(5) The .5-1 mc rf slug rack cam is operated through gears (BB), (CC), (GG), (HH), (JJ), (KK), and (LL). The 1-2 mc rf slug rack cam is operated through gears (BB), (CC), (GG), (HH), (JJ), (KK), (LL), (MM), and (NN).

(6) The gear (EEE) is shown engaged with gear (HH) through gear (FFF). Gear (EEE) does not normally engage gear (DDD), but during disassembly and reassembly procedures it prevents loss of synchronization between the KILOCYCLE CHANGE control and the MEGACYCLE CHANGE control through the differential to the 2-4 mc, 4-8 mc, 8-16 mc and 16-32 mc slug racks. One side of gear (EEE) is covered with green paint. When the green is visible, the synchronization is locked.

*d. ZERO ADJ. Control.* The ZERO ADJ. control provides a means of correcting errors in calibration. A locking screw operated by the knob releases the clutch and locks the gear (ZZ). Tuning over a range of approximately 6 kilocycles is possible without moving the three right-hand number wheels on the countertype frequency indicator. Operation of the knob in a counterclockwise direction engages the clutch and unlocks gear (ZZ).

Figure 59. Tuning system, exploded view.

(Contained in separate envelope)

## CHAPTER 5

### FIELD MAINTENANCE

*Note.* This chapter contains information for field maintenance. The amount of repair that can be performed by units having field maintenance responsibility is limited only by the tools and test equipment available and by the skill of the repairman.

---

#### Section I. TROUBLESHOOTING AT FIELD MAINTENANCE LEVEL

**Warning:** When servicing the receiver, avoid contact with the power supply and plate circuits. The high voltages present in these circuits can cause serious injury.

#### 83. Troubleshooting Procedure

*a. General.* The first step in servicing a defective Radio Receiver R-390/URR is to sectionalize the fault. Sectionalization consists of tracing the fault to the subchassis responsible for the abnormal operation of the receiver or to the front panel and main frame. The second step is to localize the fault. Localization means tracing the fault to the defective *circuit* on the subchassis or front panel and main frame. Finally, by voltage, resistance, and continuity measurements, the defective *part* is isolated. Some faults, such as burned-out resistors, shorted transformers, and loose connections often can be located by sight, smell, and hearing. The majority of faults, however, must be located by *checking voltage and resistance*.

*b. Detailed Procedure.* The tests listed below are to be used as a guide in isolating the source of the trouble. To be effective, the procedure should be followed in the order given. Remember that the servicing procedure should cause no further damage to the receiver. The procedure is summarized in (1) through (7) below, which contain references to paragraphs having detailed information for carrying out the tests.

(1) *Initial inspection.* It is often possible to locate troubles within an equipment by inspecting the condition of the wiring and detail parts for visible evidence of failure. Since this inspection (par. 89)

can be quickly and simply carried out, and is capable of yielding such rapid results, it is the first to be applied in the troubleshooting procedure. This inspection is of further value in that additional damage to the receiver that might occur through improper servicing methods can possibly be avoided.

- (2) *Checking B+ and filament circuits for shorts.* These measurements (par. 90) prevent further damage to the receiver from possible short circuits. Since this test gives an indication of the condition of the filter circuit, its function is more than preventive.
- (3) *Operational test.* After it has been determined in the preceding test that a short is not present in the receiver, an operational test (par. 91) is carried out. By using the information gained from observing the symptoms of faulty operation, it is sometimes possible to determine the exact nature of the fault.
- (4) *Troubleshooting chart.* The troubleshooting chart (par. 92) presents a systematic method for checking out the receiver by eliminating possible sources of trouble until the actual trouble is finally resolved.
- (5) *Signal substitution.* Signal substitution (pars. 94 through 99), when used in conjunction with the troubleshooting chart, provides an effective method for methodically tracking down trouble in a receiver.
- (6) *Stage gain charts.* These charts (par.

101) are useful in localizing obscure, hard-to-find troubles.

(7) *Intermittents*. In all these tests the possibility of intermittents should not be overlooked. If present, this type of trouble may be made to appear by tapping or jarring the subchassis or parts under test. It is possible that the trouble is not in the receiver itself, but in the installation (mounting, antenna, ground, auxiliary equipment, or vehicle), or the trouble may be due to external conditions. In this event, test the installation, if possible.

### 84. Troubleshooting Data

Take advantage of the material supplied in this technical manual. It will help in the rapid location of faults. Consult the following troubleshooting data:

Fig. No.	Par. No.	Description
25	77	List of series filament circuits. Radio Receiver R-390/URR, top deck, tube location.
26		Radio Receiver R-390/URR, bottom deck, tube location.
60 and 61		Fabrication of bench-test cables.
	101	Stage-gain charts.
	102	Dc resistances of transformers and coils.
	103	Rf and variable if. conversion scheme.
62 through 79		Top and bottom views of receiver subchassis, showing locations of parts.
80 and 81		Radio Receiver R-390/URR, main frame.
82 and 83		Tube-socket voltage and resistance and subchassis receptacle resistance diagrams.
107		Subchassis and interconnection diagram.
108		Radio Receiver R-390/URR, schematic diagram.

### 85. Test Equipment and Tools Required for Troubleshooting

a. The test equipment required for troubleshooting Radio Receiver R-390/URR is listed below. The technical manuals associated with

the test equipment, where applicable, are also listed.

Test equipment	Technical manual
RF Signal Generator Set AN/URM-25, or equal.	TM 11-5551.
Audio Oscillator TS-382/U, or equal.	TM 11-2684.
Electronic Multimeter TS-505/U, or equal.	TM 11-5511.
Multimeter TS-352/U, or equal.	TM 11-5527.

Figure 60. Assembly instruction for cable No. 1.

(Contained in separate envelope)

b. The tools and materials contained in Tool Equipment TE-113 are required for field maintenance of Radio Receiver R-390/URR.

### 86. Bench Testing

a. When a cause of equipment failure has been sectionalized to a subchassis, as determined by visual inspection, operational test, or the use of the troubleshooting chart, a bench test of the faulty subchassis may be required to locate the trouble through voltage readings. Since the undersides of the subchassis are not accessible for troubleshooting when the subchassis are mounted in the receiver, it may be necessary to remove the subchassis under test and connect them to the receiver circuits by the extension cables. Directions for the fabrication of the extension cables are given in figures 60 and 61. The amount and type of extension needed can be determined from the chart in *b* below.

b. To prepare a subchassis for bench testing, remove the subchassis from the receiver according to the instructions contained in paragraph 105. *Avoid the possibility of disturbing the synchronization of the gear train with the rf subchassis, crystal oscillator subchassis, and vfo subchassis.* Connect the extension cables between the receiver and subchassis according to the chart below.

**Caution:** When the subchassis are operated outside the receiver, dangerous voltages are exposed at the tube-socket pins and other points on the undersides of the chassis. Observe the rules for servicing in the presence of high voltage to prevent possible injury.

Subchassis	Cable No.	Connect between
Rf.....	1	P209-J109
	1	P210-J110
	1	P211-J111
	1	J223-P723
	1	P224-J924
	1	P225-J525
	1	P226-J526
		P221-J421
		P222-J422
		J214-P114
Af.....	3	J619-P119
	4	J620-P120
Ac power supply.....	5	J818-P118
Crystal oscillator.....	6	J413-P113
	1	J421-P221
	1	J422-P222
Vfo.....	7	P715-J115
	1	P723-J223
Calibration oscillator.....	7	P916-J116
	1	J924-P224
If.....	1	J512-P112
	1	J525-P225
	1	J526-P226
	8	J517-P117

## 87. General Precautions

When a receiver is to be serviced, observe the following precautions very carefully:

*a.* When the receiver is removed from the case, cabinet, or rack for servicing, connect an adequate ground to the main frame and to any subchassis operated outside the main frame before connecting the power cord.

*b.* Make certain that the receiver is disconnected from the power source or is turned off before contacting high-voltage circuits or changing connections.

*c.* After disconnecting auxiliary equipment and before testing the receiver, connect pairs of terminals on the back-panel terminal strips as shown in figure 22.

*d.* After disconnecting tuning shafts for removal of a subchassis, avoid turning the shafts or tuning controls unless necessary for troubleshooting or adjustment. Careful handling may eliminate the need for synchronization. It will be helpful to make a note of the positions of the front-panel controls indicated in the removal procedure upon removal of a subchassis, since a control may be inadvertently disturbed during servicing.

*e.* Careless replacement of parts often makes new faults inevitable. Note the following points:

- (1) Before unsoldering a part, note the position of the leads. If the part has a number of connections, tag each of its leads.
- (2) Be careful not to damage other leads while pulling or pushing them out of the way.
- (3) Do not allow drops of solder to fall into the receiver, since they may cause short circuits.
- (4) A carelessly soldered connection may create a new fault. It is very important to make well-soldered joints, since a poorly soldered joint is one of the most difficult faults to find.
- (5) *When a part is replaced in the rf or if circuits, it must be placed in the exact position of the original part. A part that has the same electrical value but different physical size may cause trouble in high-frequency circuits. Give particular attention to proper grounding when replacing a part. Use the same ground as in the original wiring. Failure to observe these precautions may result in decreased gain or, possibly, in oscillation of the circuit.*

*f.* Before taking voltage measurements or performing signal tracing, always check the value of the regulated dc voltage. Approximately 180 volts dc should be obtained at B+ 180V DC jack, J601, located on the af subchassis (fig. 75). This jack is accessible through the main frame of the receiver, at the side.

## 88. Troubleshooting Notes

*a.* To avoid the necessity for removing a subchassis when voltage is to be measured or signal injected at a tube-socket pin that does not have a test point, remove the tube, insert into the desired contact a short length of thin insulated wire having both ends bared, and replace the tube. Connection to a voltmeter or signal generator then can be made through the exposed end of the wire. The rf tuning coils and transformers on the rf subchassis can be readily removed, if necessary, to permit measurement of voltage or resistance at the socket contacts, or measurement of the continuity of the coils. Instructions for the removal of the coils and transformers are contained in paragraph 105*g*.

*b.* If trouble is suspected in the rf subchassis, perform as much detailed troubleshooting as pos-

sible to make certain that the trouble is in the subchassis before removing it as removal of the rf subchassis is a difficult and time-consuming procedure.

c. When it is suspected that injection voltage from vfo is not being supplied to the third mixer, check the 3TF7 voltage regulator tube. If the tube does not glow, or if an excessive glow is noted, replace the tube.

d. When the filament of a particular tube fails to light, trouble may be in another tube in the same series filament circuit. Refer to the series filament circuit diagram (fig. 54).

e. When trouble appears to be in regulator tube V605, V606, or V607, first observe that tubes V608 and V609 are glowing normally, and then check B+ voltage at the B+ 180V DC jack before testing regulator tubes in the tube tester.

## 89. Initial Inspection

When a receiver is brought in from the field for check or repair, remove the top and bottom dust covers, and inspect it as follows, observing the precautions described in paragraph 87.

a. Inspect all cables, plugs, and receptacles. *Check to see that all connectors are seated properly.* This is important because improperly seated connectors are a frequent cause of abnormal operation in equipment. Repair or replace any connectors or cables that are broken or otherwise defective.

b. Inspect for burned insulation and resistors that show signs of overheating. Look for wax leakage and any discoloration of apparatus and wires.

c. Inspect for broken connections to tube sockets, plugs, and other apparatus, as well as for defective soldered connections. Examine for bare wires touching the chassis or adjoining wires.

d. Make sure that all tubes are in their correct positions as shown in figures 25 and 26. Replace or interchange any tubes that are not of the type called for in the illustrations. Replace broken tubes. Inspect for loose tube-socket contacts.

e. Inspect the fuses and replace, if necessary, with fuses of correct rating and type. Check carefully for short circuits (par. 90) wherever a blown fuse is found.

f. See that the MEGACYCLE CHANGE and KILOCYCLE CHANGE controls turn freely. Rough operation or binding indicates a damaged

tuning system or need for cleaning and lubrication (par. 106).

g. Check all switches and controls for ease of operation.

## 90. Checking B+ and Filament Circuits for Shorts

a. To prevent damage to a receiver sent in for repair, always check the resistance of the high-voltage circuits before applying power to the equipment. Repeated burning out of B+ 3/8A fuse, F102, is an indication of a short in one of the high-voltage circuits. Disconnect Power Cable Assembly CX-1358/U from the ac power input, and test the cable assembly (par. 44). After it has been determined that the cable assembly is normal, set the FUNCTION switch at AGC and check the high-voltage circuits as follows:

(1) The resistance measured between the chassis and tube-socket pin 2 or 5 of regulator tube V605 and V606 should be approximately 140,000 ohms. This measurement can be taken at the 3/8A fuse holder by leaving the fuse in place. If the resistance is low, check capacitor C101 (fig. 81) for a short circuit or leakage. If the resistance is abnormally high or infinite, check for an open circuit caused by a break in wiring, poor connector contact, or, possibly, an open capacitor C101.

(2) The resistance measured between the chassis and the B+ 180V DC jack J601 should be approximately 19,000 ohms with the FUNCTION switch at OFF or STAND BY, approximately 9,400 ohms with the FUNCTION switch at AGC, MGC, or CAL, and approximately 8,500 ohms with the FUNCTION switch at SQUELCH. If the resistance is low, check for a short-circuited or leaking bypass capacitor, or for a short circuit in the wiring of one of the plate or screen-grid circuits of the individual subchassis. If the resistance measured is greater than normal, an open screen-grid bleeder and/or dropping resistor is indicated.

(3) If the tests outlined in (1) and (2) above indicate that a short circuit is present in the receiver, determine in which subchassis it is located, as follows:

(a) Turn the FUNCTION switch to OFF.

- (b) Disconnect all interconnecting cables that carry power to the subchassis.
- (c) Replace any blown fuses.
- (d) Check to see that the 115V/230V switch on Power Supply PP-621/URR is in the proper position for the available ac power source, and connect Power Cable Assembly CX-1358/U between the receiver and power source. Turn the FUNCTION switch to AGC.
- (e) Reconnect (one at a time) the cables that carry power to the individual subchassis in the following order: Power Supply PP-621/URR, af subchassis, if. subchassis with the BFO switch in ON position, vfo subchassis, crystal-oscillator subchassis, rf subchassis, and crystal-calibrator subchassis with the FUNCTION switch in CAL position. If the B+ 3/8A fuse blows after the power cable is connected to a subchassis and, in the case of the if. and rf subchassis, the BFO and FUNCTION switches, respectively, are turned to the positions indicated, there is probably a short circuit in that subchassis.

b. If the tests performed as instructed in a(1), (2), and (3) above reveal no trouble, the filament circuits should be checked as follows:

- (1) See that all the necessary interconnecting cables are in position and properly connected.
- (2) Turn the FUNCTION switch to AGC, and check the filament circuits as described in paragraph 42. A short in the low-voltage or filament circuits will be evidenced by the repeated burning out of AC 3A fuse, F101. In addition to a defective filament circuit, a short circuit to ground in oven heater HR401, HR701, or HR901, or dial lamps I 101 or I 102 will seriously affect the low-voltage circuit. If an abnormal filament circuit is indicated, test the tubes by using one of the techniques described in paragraph 43.

## 91. Operational Test

a. Operate the equipment as described in the equipment performance check list (par. 47). This check list is important because it frequently aids in sectionalizing the trouble without the need for further testing. Check for overheated parts,

faulty controls, and intermittent operation. Observe closely the readings of the CARRIER LEVEL and LINE LEVEL meters. A normal reading on the CARRIER LEVEL meter usually indicates satisfactory operation of the age circuit and all stages up to and including the fifth if. amplifier. If the LINE LEVEL meter reading is normal, satisfactory operation of the remaining stages, except for second af amplifier, section A of V602, and the local audio channel output stage, V603, is indicated. These latter stages can be checked by listening with a 600-ohm headset or speaker.

b. To check the local audio and if. stages quickly, connect a headset to the PHONES jack on the front panel. Turn the FUNCTION switch to AGC. Starting at the 16-KC position of the BANDWIDTH switch, set the switch in turn to each lower position. If the volume of the rushing sound heard in the headset decreases noticeably with each lower setting, the if. and local audio stages are operating. This test does not necessarily indicate normal operation.

c. The calibration-oscillator signal can be used as a convenient means of quickly localizing trouble in the receiver. Typical methods are described in (1) and (2) below.

- (1) To check the contacts of the rf band switch (S201 through S210) (fig. 64) and crystal-oscillator band switch (S401 through S404) (fig. 66), connect a headset to the PHONES jack on front panel. Set the FUNCTION switch at CAL. Set the KILOCYCLE CHANGE control to any 100-kc position. Starting with the lowest detent position of the MEGACYCLE CHANGE control, turn the control to each detent position in succession. Adjust the BFO PITCH control as necessary to obtain a signal in the headset. If no audible signal is heard in a detent position, trouble in contacts of the rf band switch or crystal-oscillator band switch is indicated.

- (2) The LINE LEVEL meter, LINE METER switch, and LINE GAIN control are checked as follows: connect a headset to the PHONES jack on the front panel and adjust the KILOCYCLE CHANGE control for an even 100-kc reading on the dial. Set the FUNCTION switch at CAL and turn the BFO

switch to ON; an audible tone should be heard in the headset. Set the LINE METER switch to -10 and adjust the LINE GAIN control so that the LINE LEVEL meter reads 0 vu (upper scale). Turn LINE METER switch to 0. Reading on LINE LEVEL meter should drop to -10 vu. Readjust the LINE GAIN control for a 0-vu reading on LINE LEVEL meter. Turn the LINE METER switch to +10. The LINE LEVEL meter reading should drop to -10 vu. If indications described above are not obtained, check the LINE LEVEL meter and 10-db pads (fig. 85), the LINE METER switch, and the LINE GAIN control.

d. The synchronization of the tuning shafts can be quickly checked as follows:

- (1) Set the frequency-indicator reading so that the first two digits are zeros and the last three digits read an even 100 kc or multiple thereof.
- (2) Set the FUNCTION switch at CAL.
- (3) Advance the RF GAIN control until the reading is obtained on the CARRIER LEVEL meter.
- (4) Raise the .5- to 1-mc slug rack (fig. 86) slightly with the hand; the CARRIER LEVEL meter reading should decrease.

**Caution:** To prevent damage do not depress the slug rack too strongly.

- (5) Depress the .5- to 1-mc slug rack slightly with the hand; the meter reading should decrease. If the reading increases when the slug rack is either raised or depressed, the camshaft is out of synchronization.
- (6) Repeat the procedures described in (1) through (5) above for each slug rack, setting the megacycle digits on the frequency-indicator dial at a reading within the band covered by the slug rack being checked.

e. If the receiver is not synchronized, refer to paragraph 111.

## 92. Troubleshooting Chart

The following chart is supplied as an aid in locating trouble in the radio receiver. This chart lists the symptoms that the repairman observes, either visually or audibly while making simple tests. The chart also indicates how to localize trouble quickly to the audio, if. or rf stage that is defective. The signal-substitution tests outlined in paragraphs 94 through 99 can then be used to supplement this procedure to aid in locating the defective stage. Once the trouble has been localized to a stage or circuit, a tube check and voltage and resistance measurements of the stage or circuit should ordinarily be sufficient to isolate the defective part.

Symptom	Probable trouble	Correction
1. When FUNCTION switch is in AGC position, receiver fails to operate and dial lamp does not light.	Open AC 3A fuse (F101) on rear panel of receiver.	Replace fuse. If it blows again, check power supply, filament, and oven circuits for shorts. Check primary power connections.
2. Dial lamp lights, but CARRIER LEVEL meter does not deflect. No reception.	No. B+ voltage. Open B+ $\frac{1}{2}$ A fuse (F102) on rear panel of receiver.	Replace fuse. If it blows again, test capacitor C101 for short. Test plate and screen-grid circuits for shorts (par. 90).
3. No receiver output. CARRIER LEVEL meter raises and dips as KILOCYCLE CHANGE control is rotated.	Fault is in signal circuit after 5th if. stage.	Connect headset in series with a .1-UF capacitor across grid circuit and plate circuits of successive audio stages to localize defective stage. Stage may also be localized by signal substitution (pars. 95 and 96). Test tube of defective stage. (Note series filament circuits (par. 42).) If necessary, check voltages and then resistances of circuits within a stage (fig. 83) to locate a defective part.
4. Af. circuits function satisfactorily, but no signal output is obtained when 455-kc modulated signal is applied to if. input (J525 or J526, fig. 68)	Faulty if. stage-----	Test if. stages by signal substitution method (par. 98). Test tubes. When necessary, localize fault by voltage and resistance measurements (fig. 82).



Symptom	Probable trouble	Correction
5. If circuits respond to 455-kc signal but no station is received.	Crystal oscillator band switch or vfo tuning shaft out of synchronization. Faulty mixer, oscillator, or rf stage.	Check synchronization of band switch and tuning shaft (par. 110). Test mixer stages, rf stages, and crystal oscillators by signal substitution method (pars. 99 and 100).
6. No beat frequency heard when BFO switch is turned ON and BFO PITCH control varied.	Faulty bfo.....	Test tube V508. Check voltages at tube-socket pins (fig. 82). Check BFO switch.
7. No calibration signal when FUNCTION switch is at CAL.	Defective calibration oscillator..	Test tubes V901 and V902. Substitute crystal Y901 for one that is known to be good. Check voltages and resistances of oscillator circuits (fig. 83).
8. Excessive hum from ac power supply.	Defective filter capacitor or electronic voltage regulator.	Adjust HUM BAL control, R614 (par. 109). Check C101. Test tubes V605, V606, and V607 (par. 88e). Check voltage across reference tubes V608 and V609. Check C607 for capacitance and leakage. Check voltage and resistance of voltage regulator (fig. 83).
9. Weak signal.....	Low voltage. Weak tubes.....	Check power-input voltage. Check B+ voltage at J601 (fig. 75). Test tubes. Check gain of each stage to localize trouble (par. 101). Check for shorted capacitors. If no fault is indicated by a thorough check of tubes and voltages when the output is weak, align tuning circuits (pars. 108 through 120).
10. Noisy receiver.....	Noisy antenna location. Poor connection or shorting elements within a tube.	Short-circuit antenna to ground by setting FUNCTION switch to CAL. (Receiver must not be tuned to even 100-kc frequency, or calibration signal will interfere with test.) A considerable decrease in noise indicates noisy signal from antenna. Use insulated prod to tap each tube. If tapping a tube causes increase in noise in the output, try different tube.
	Loose connection at a terminal or within a part.	Tap the parts. Move terminals slightly, and listen for noisy output. Noise indicates that a connection should be soldered or that a part needs replacing.
11. Receiver output noisy when controls are operated.	Dirty switch contacts. Poor contact at rotor of a gain control.	Clean switch contacts. Clean and lubricate control, or replace.
12. Distorted signal.....	Weak tube. Incorrect voltage on tube. Leaky capacitor, such as C603 or C610.	Check tubes and replace if necessary. Check voltages and resistance in af subchassis (fig. 83). Use headset connected in series with a .1- $\mu$ f capacitor to check signal across grid and plate circuits of audio stages and, thus, to localize trouble.

### 93. Voltage and Resistance Checks

Voltage and resistance diagrams for the various subchassis of the receiver are shown in figures 82, 83, and 84. These drawings show the values that should be obtained at the tube-socket pins, subchassis receptacles, and terminal boards. If a value, as read on the multimeter, varies (outside of reasonable tolerance limits) from the value

given in the diagrams, the amount of variance should be noted and used to aid in determining which part is at fault. For instance, if a 100,000-ohm resistance reading is indicated at a given tube-socket pin on a diagram, and the actual reading is 30,000 ohms on the meter, the circuit diagram of the subchassis should be examined for the presence of a resistor in the circuit under test that could, if defective, account for the incorrect read-

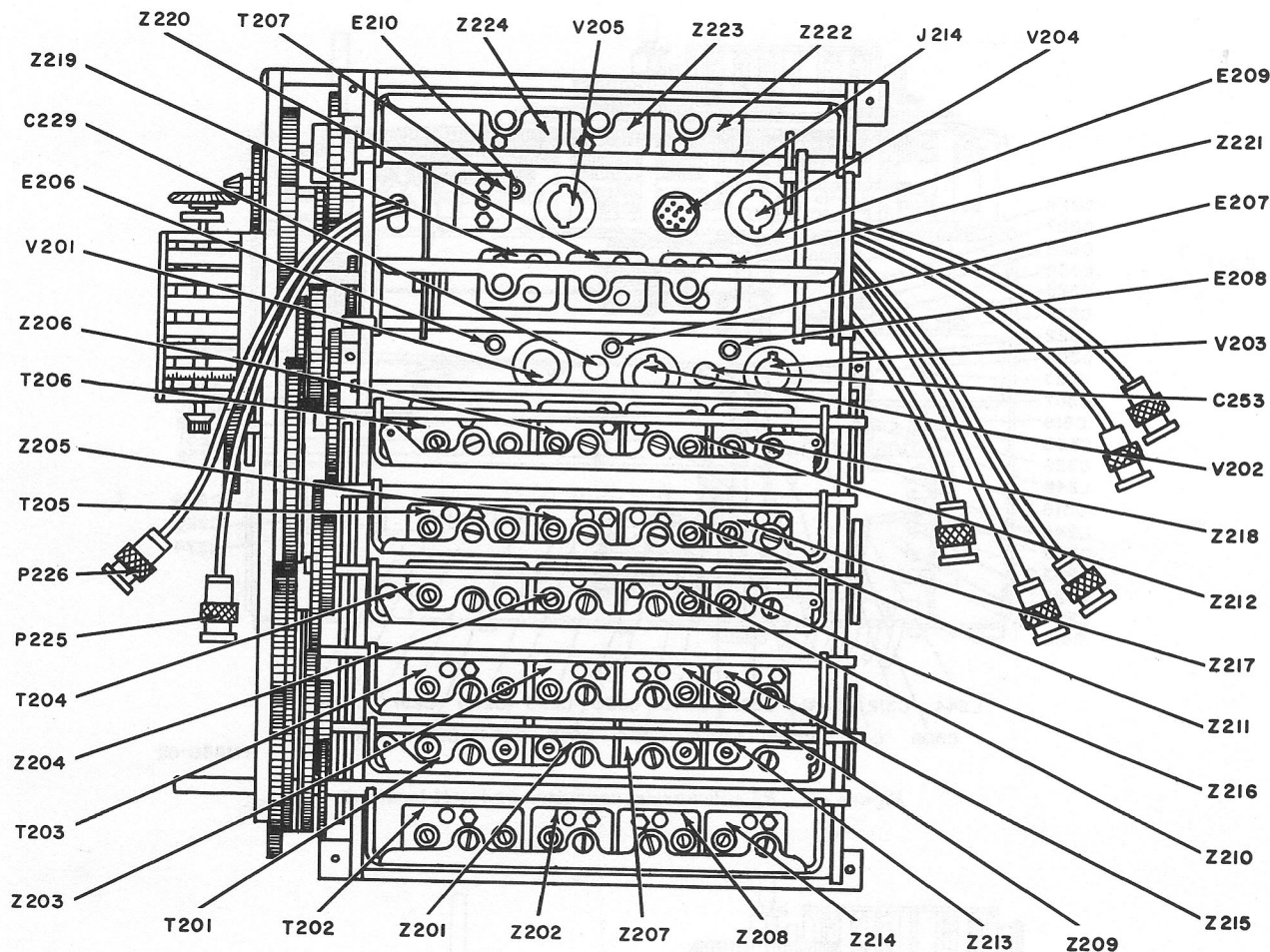

TM 856-61

Figure 62. Rf subchassis, top view.

ing. Such a resistor would then be suspected and should be checked. Another possibility would be that a capacitor has shorted out and is shunting a resistor. There are many ways of using the voltage and resistance diagrams, depending on the resourcefulness of the repairman.

#### 94. Signal Substitution Notes

*a.* Signal substitution for Radio Receiver R-390/URR requires an audio oscillator, such as Audio Oscillator TS-382/U, for checking the line and local audio channels, and a signal generator, such as RF Signal Generator Set AN/URM-25, to provide a source of modulated rf and if. signals for checking the rf, variable if., and fixed if. stages. In addition to producing an if. signal of 455 kc, the signal generator should cover an rf range of at least 400 kc to 32 mc. The signal gen-

erator should be capable of furnishing an rf signal output at any level between 1 microvolt and 1 volt.

*b.* A multimeter, such as Electronic Multimeter TS-505/U, and tube tester, such as Electron Tube Test Set TV-2/U, are needed to isolate the defective part after the faulty stage has been indicated by signal substitution.

*c.* For the tests described in paragraphs 95 through 99 inclusive, connect the ground lead of the audio oscillator or signal generator to the subchassis being tested, and connect the signal output lead through a capacitor (aprx. .05  $\mu$ f), to the point specified. The bench-testing information in paragraph 86 and the information in paragraph 88*a* indicate the method of preparing the subchassis for signal tracing.

*d.* Note the volume, and listen for distortion from the speaker or headset at various points in

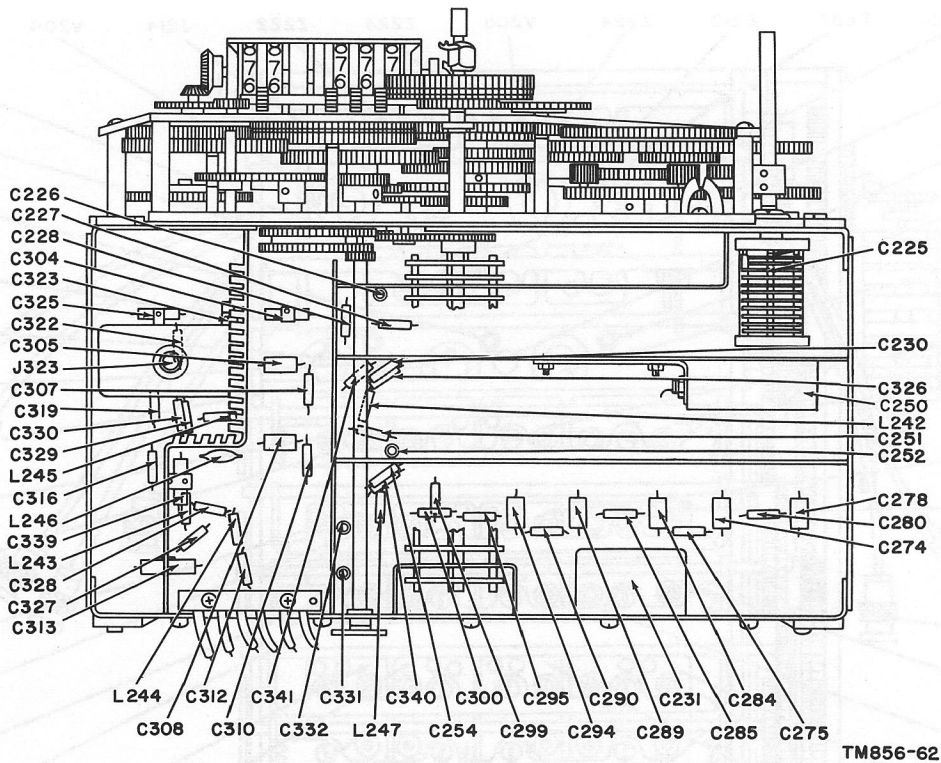

Figure 63. Rf subchassis, capacitor and coil location.

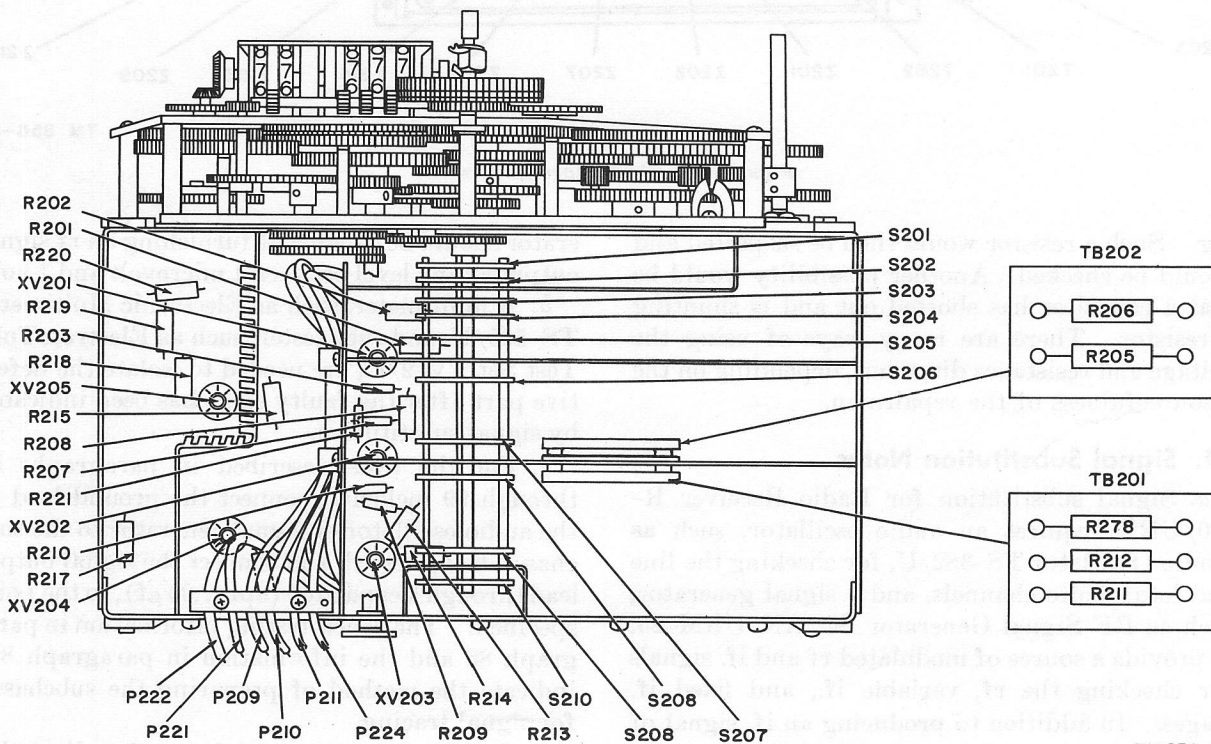

Figure 64. Rf subchassis, bottom view.

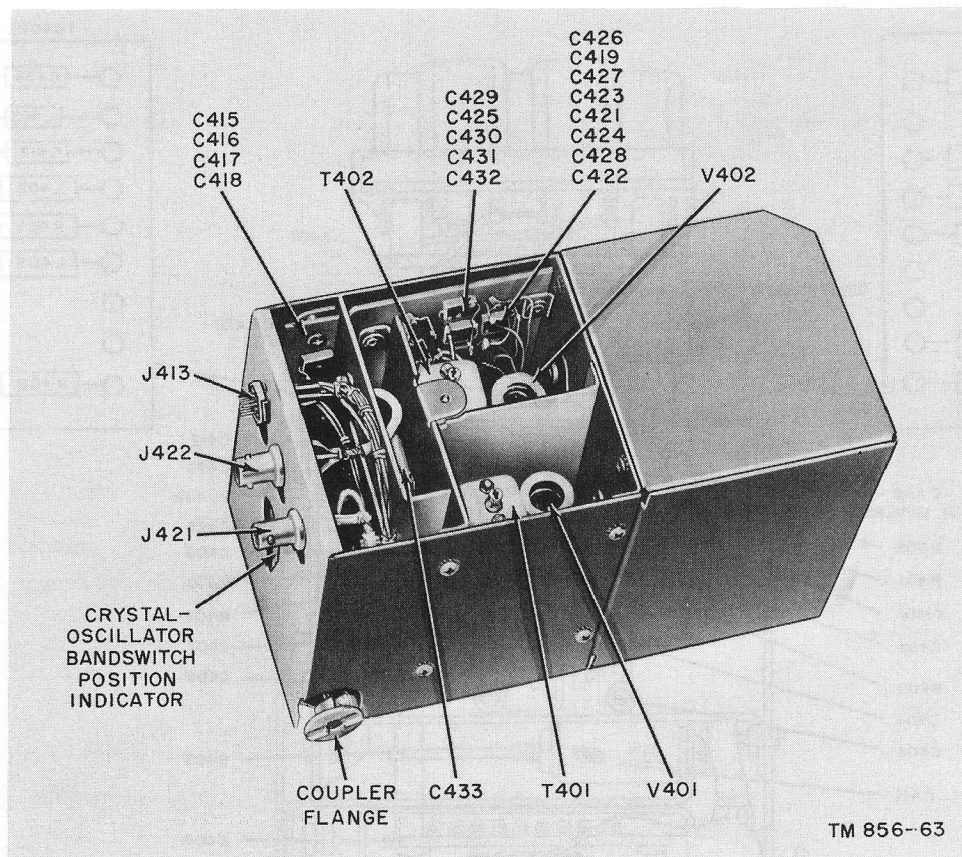

Figure 65. Crystal-oscillator subchassis, top view.

the signal-substitution procedure. Make certain that the LIMITER control is in the OFF position: if it is in the ON position, it may be the cause of the distortion. When working back from the output to the input stages, decrease the output of the signal generator as much as possible. If possible, compare results with a receiver known to be in good condition.

*e.* Check the wiring and soldering in each stage during the procedure.

*f.* A tuning shaft that is out of synchronization or a trimmer adjustment that is misaligned may cause reduced output or may prevent any output. Synchronization of the shafts and cams (par. 110*a*) should be checked, and the position of the rf and crystal oscillator band switches should be checked (par. 110*b* and *c*) before the adjustment of individual tuning circuits (pars. 111 through 116) is attempted.

*g.* When trouble is localized in a given stage, first test the tube, if such a test is indicated. Then

measure the voltage and, finally, the resistance of the circuits of that stage (figs. 82, 83, and 84).

*h.* Trouble in a circuit or stage does not always change the voltage and resistance measurements at the tube socket or terminal board. Instructions included in this paragraph merely serve as a guide, and suggest other procedures, such as voltage and resistance measurements of individual parts.

*i.* When testing, remove only *one* tube at a time. Check the type number of the tube, test the tube, and, if it is not defective, return it to its proper socket before removing another tube.

*j.* At each step it is assumed that all previous steps were completed satisfactorily. Isolate and clear any trouble discovered before proceeding with succeeding steps.

*k.* Refer to the notes in paragraph 88 while performing the tests.

## 95. Local-Audio-Channel Tests

*a.* Pin 5 of V603 (Plate of Local AF output Tube). Apply an af signal to pin 5 of tube socket

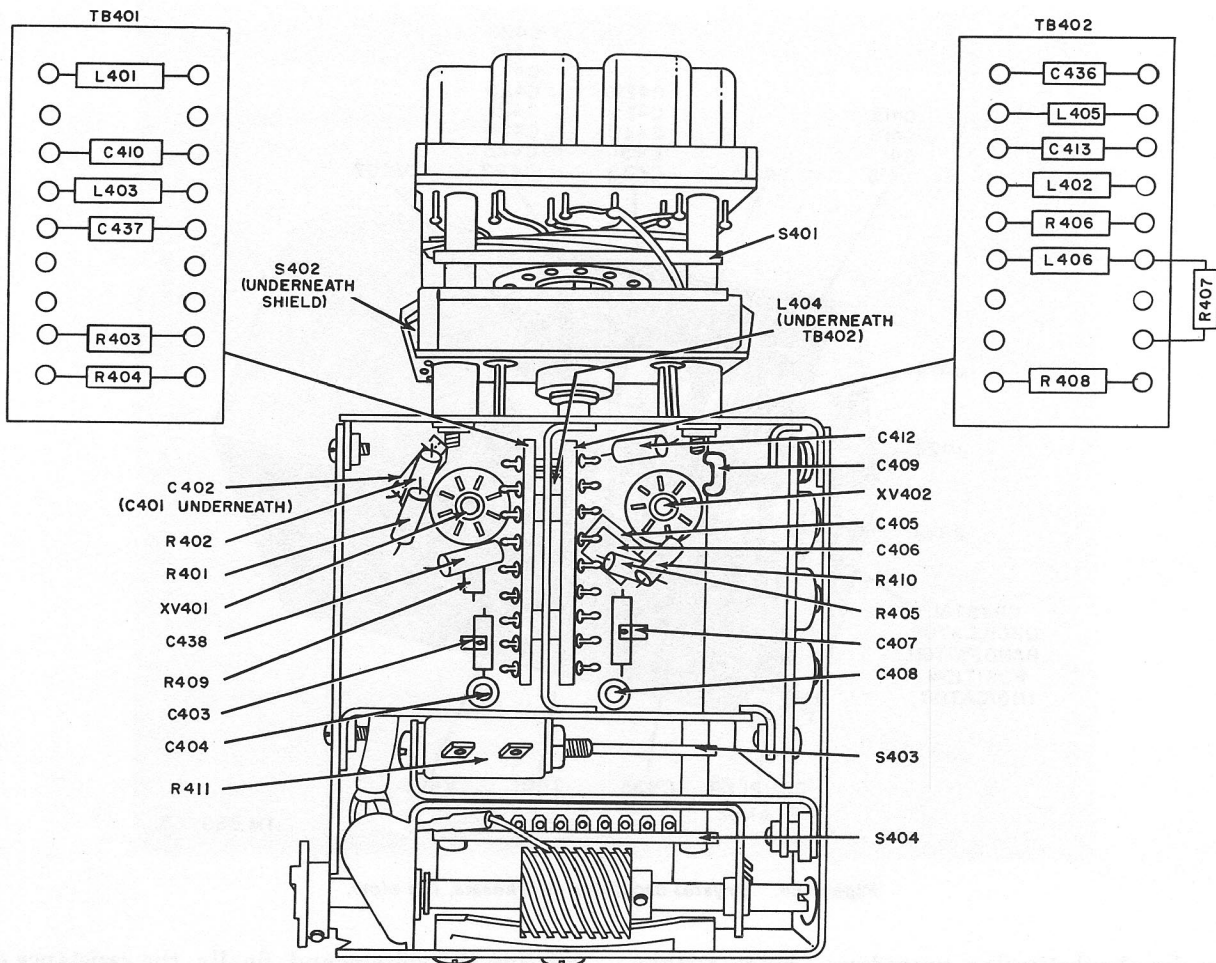

Figure 66. Crystal-oscillator subchassis, bottom view.

TM856-64

XV603 (fig. 75). Listen to the signal from a headset or speaker connected to the local audio output. The volume should be very low. If no signal is audible, check the connections to output transformer T602, and test capacitor C604 for a short circuit (fig. 75).

b. Pin 1 of V603 (Grid of Local Af Output Tube). Apply the signal to pin 1 of tube socket XV603. Listen for an increased output over that obtained in the preceding step (a above). If no signal is audible, test the tube and the voltages at the socket pins. When the signal is distorted or when there is a positive dc voltage on the control grid with respect to the chassis, test capacitor C603 for leakage (fig. 75).

c. Pin 1 of V602 (Plate of Local Af Amplifier). Connect the output of the generator to pin 1 of tube socket XV602 (fig. 75). If the signal output decreases, test capacitor C603 (fig. 75).

d. Pin 2 of V602 (Grid of Local Af Amplifier). Turn the LOCAL GAIN control fully on. Apply the signal to pin 2 of tube socket XV602. The output signal should be much louder than that obtained in the previous step (c above). If the signal is weak, check the tube and the voltages at the tube socket pins (fig. 83).

## 96. Line-Audio-Channel Tests

Connect the headset to the LINE AUDIO output, terminals 10 and 13 of the rear terminal strip (fig. 22). After the LINE LEVEL meter has been checked, using Multimeter TS-352/U, it may be used as an output indicator. Rely on the headset, however, to detect noise and distortion.

a. Pin 5 of V604 (Plate of Line Af Output Tube). Insert the audio-oscillator signal at pin 5 of tube socket XV604 (fig. 75). The volume

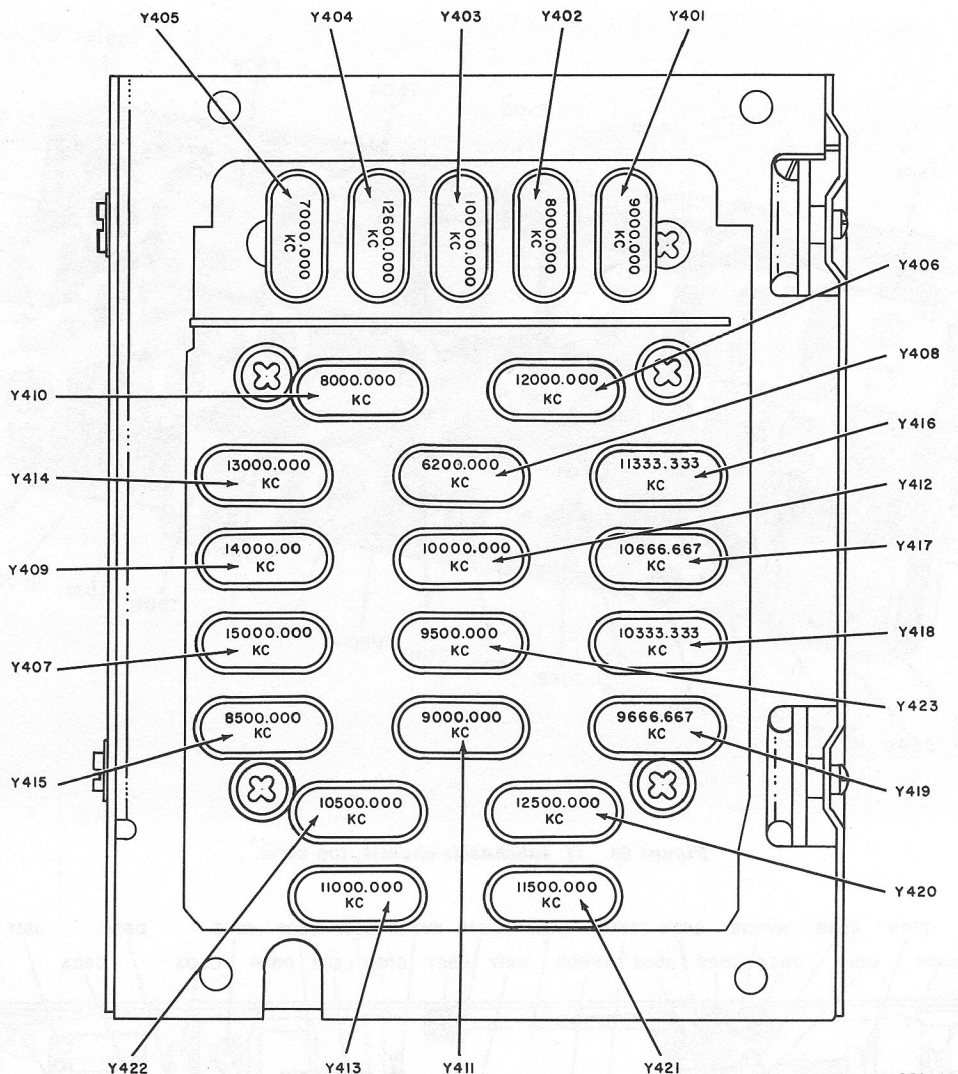

Figure 67. Crystal-oscillator subchassis, location of crystals.

TM 856-65

should be very low, as heard in the headset. If no signal is audible, check the leads to output transformer T603. The center leads of the secondary winding must be connected by a jumper between terminals 11 and 12 of the rear terminal strip (fig. 22). Test capacitor C611 (fig. 75).

b. *Pin 1 of V604 (Grid of Line Af Output Tube)*. Apply the signal to pin 1 of tube socket XV604. The output signal should be much louder than that obtained in the previous step (a above). If the output is unsatisfactory, check the tube and the voltages at the tube socket pins (fig. 83). If the grid bias is incorrect, as indicated by distortion or excessive plate current, check capacitor C610 for leakage (fig. 75). Check the operation

of the LINE METER switch and the LINE LEVEL meter.

c. *Pin 6 of V602 (Plate of Line Af Amplifier)*. Apply the audio-oscillator signal to pin 6 of tube socket XV602 (fig. 75). Rotate the LINE GAIN control fully on. If the signal output decreases noticeably, test capacitor C610 (fig. 75).

## 97. Af Amplifier Tests

a. *Pin 6 of V601 (Plate)*. Introduce the signal from the audio-oscillator at pin 6 of tube socket XV601 (fig. 75). Set the AUDIO RESPONSE switch to MED. The signal output should be somewhat less than that obtained when the signal was applied to pin 7 of V602. If no signal is heard, or if the signal is weak, check capacitor

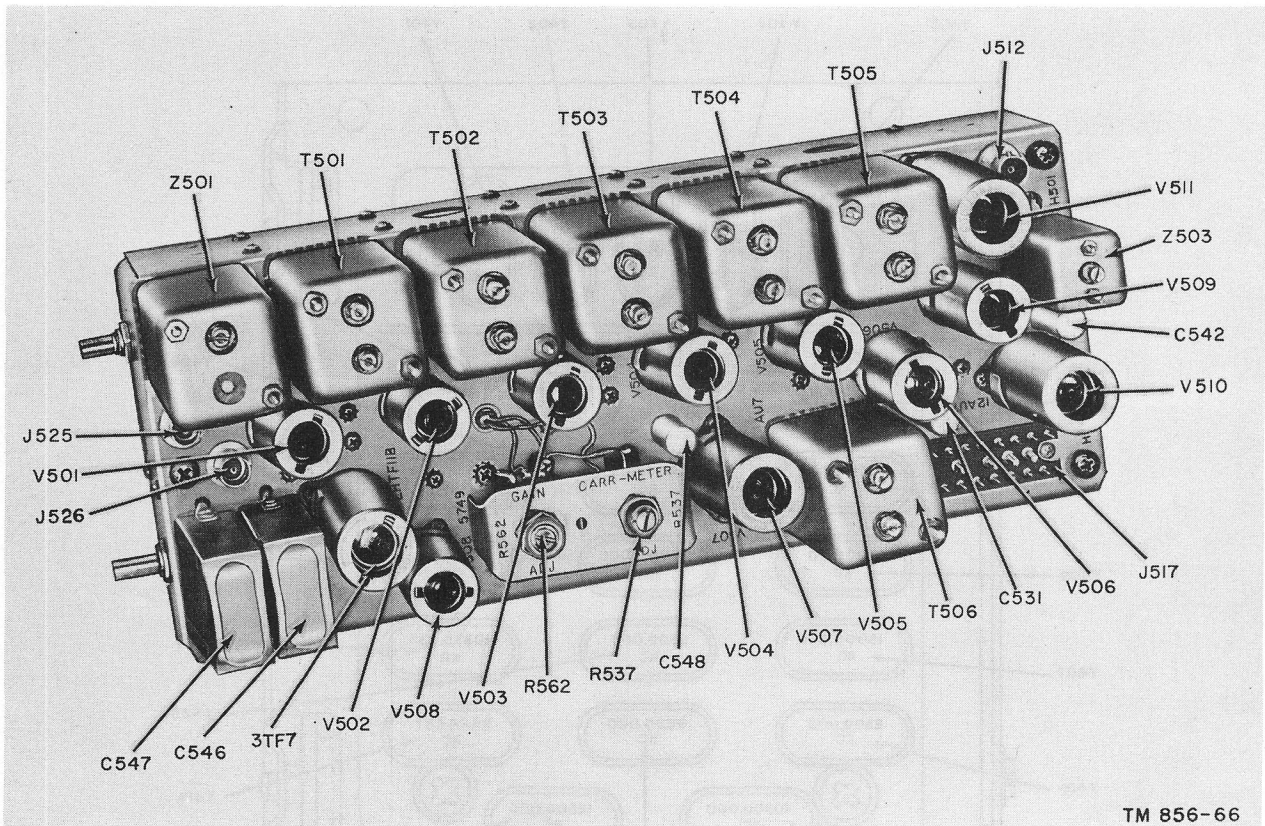

Figure 68. If. subchassis chassis, top view.

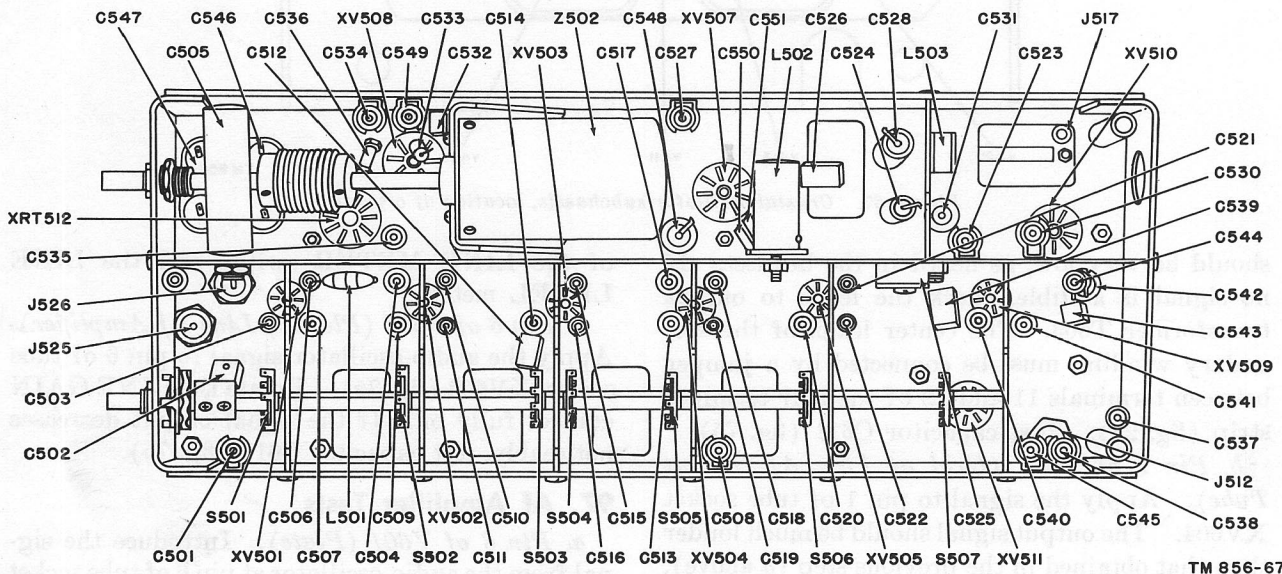
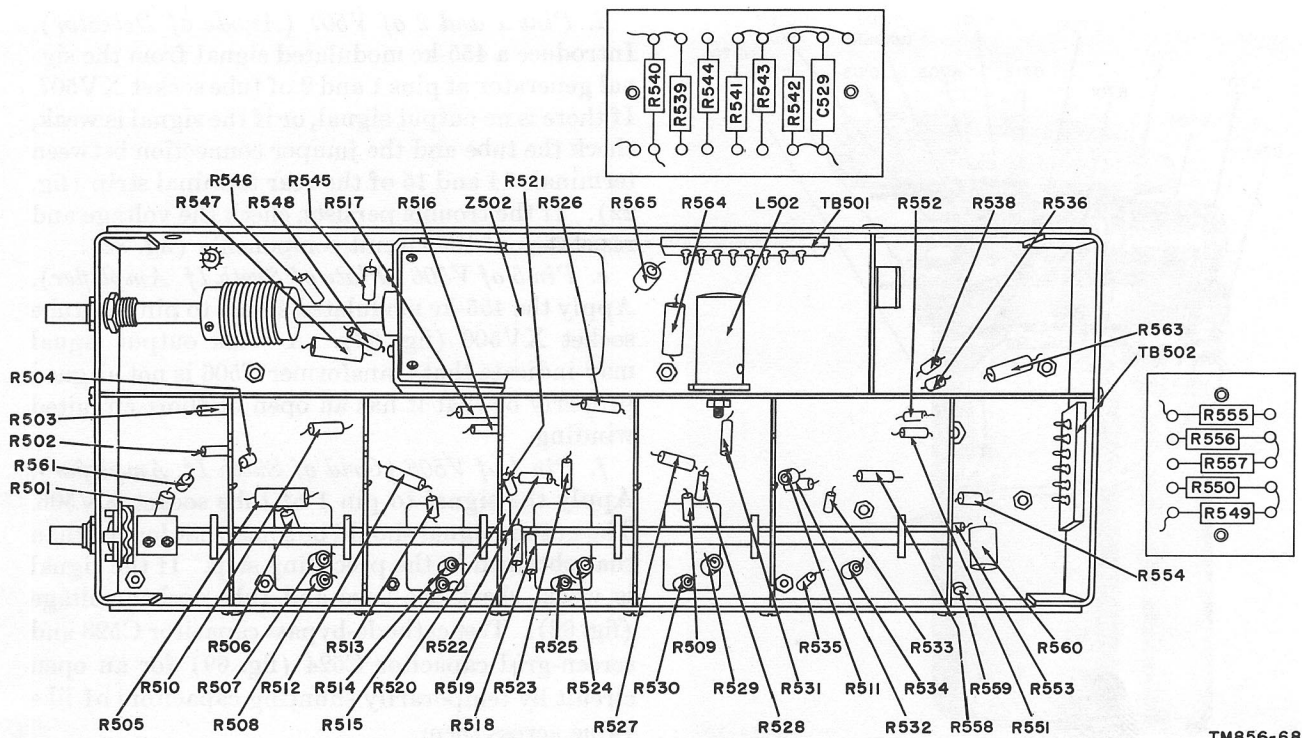
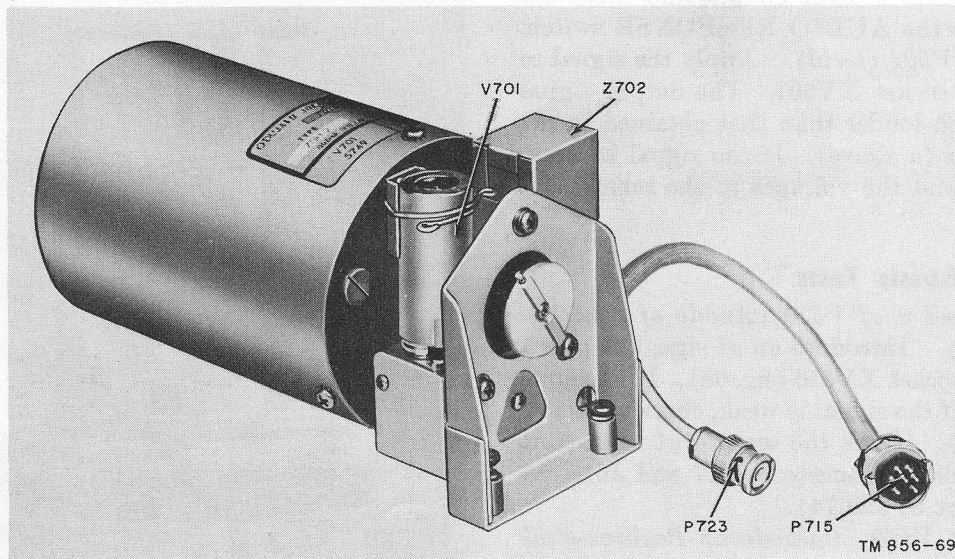

Figure 69. If. subchassis, bottom view.



TM856-68

Figure 70. If subchassis, location of resistors.



TM 856-69

Figure 71. Vfo subchassis, top view.



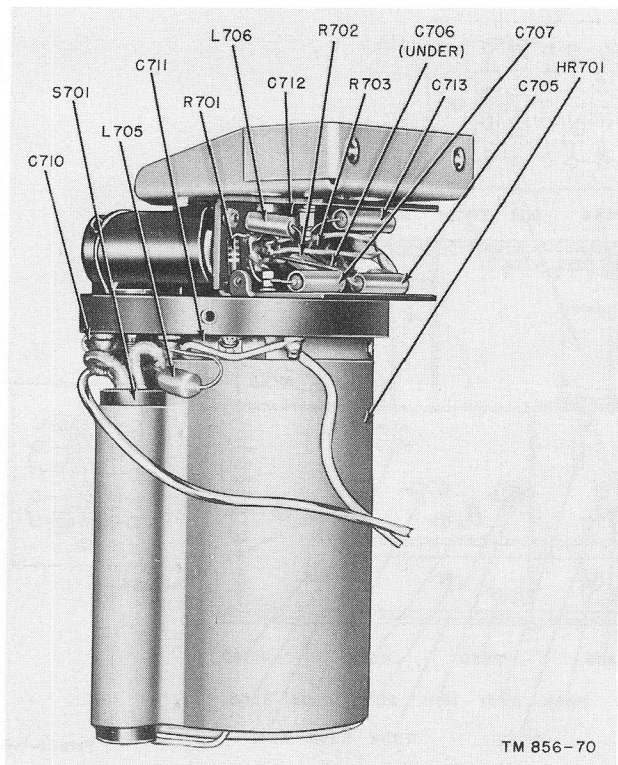

Figure 72. Vfo subchassis, bottom view.

C602 (fig. 75) for a short circuit, and check the connections to the AUDIO RESPONSE switch.

*b. Pin 7 of V601 (Grid).* Apply the signal to pin 7 of tube socket XV601. The output signal should be much louder than that obtained in the preceding step (*a* above). If the signal is weak, test the tube and the voltages at the tube socket pins (fig. 83).

## 98. If. Subchassis Tests

*a. Pins 1 and 2 of V510 (Anode of Positive-Peak Limiter).* Introduce an af signal at pins 1 and 2 of tube socket XV510 (fig. 69). If no signal is audible, or if the signal is weak, check capacitor C529 (fig. 70). Check the seating of connectors P117 and P119 in connectors J517 and J619, respectively (figs. 68 and 74).

*b. Pin 3 of V510 (Cathode of Positive-Peak Limiter).* Apply the af signal to pin 3 of tube socket XV510. A weak signal may indicate that V510 is defective or that resistor R542 or R544 is open (fig. 70).

*c. Pins 6 and 7 of V507 (Anode of Negative Peak Limiter).* Apply the af signal to pins 6 and 7 of tube socket XV507 (fig. 69). If the signal is weak, check V507 and resistor R541.

*d. Pins 1 and 2 of V507 (Anode of Detector).* Introduce a 455-kc modulated signal from the signal generator at pins 1 and 2 of tube socket XV507. If there is no output signal, or if the signal is weak, check the tube and the jumper connection between terminals 14 and 15 of the rear terminal strip (fig. 22). If the trouble persists, check the voltage and resistance of the circuit components (fig. 82).

*e. Pin 5 of V506 (Plate of Sixth If. Amplifier).* Apply the 455-kc modulated signal to pin 5 of tube socket XV506 (fig. 69). A weak output signal may indicate that transformer T506 is not aligned properly or that it has an open or short-circuited winding.

*f. Pin 1 of V506 (Grid of Sixth If. Amplifier).* Apply the signal to pin 1 of tube socket XV506. The output signal should be somewhat louder than that obtained in the preceding step. If the signal is weak, check the tube and tube socket voltage (fig. 82). Test cathode-bypass capacitor C523 and screen-grid capacitor C524 (fig. 69) for an open circuit by temporarily shunting capacitors of like value across them.

*g. Pins 5 and 1 (Plate and Grid of First Five If. Amplifiers).* Set the FUNCTION switch at

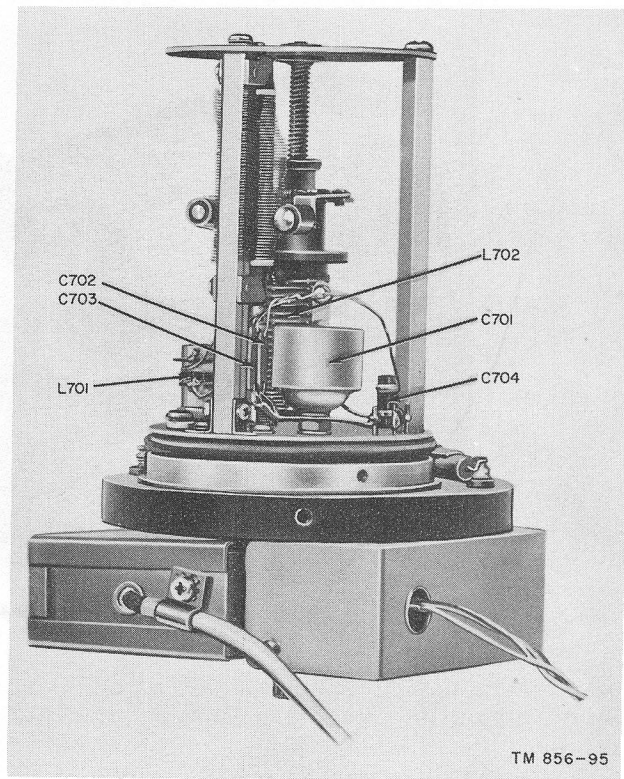
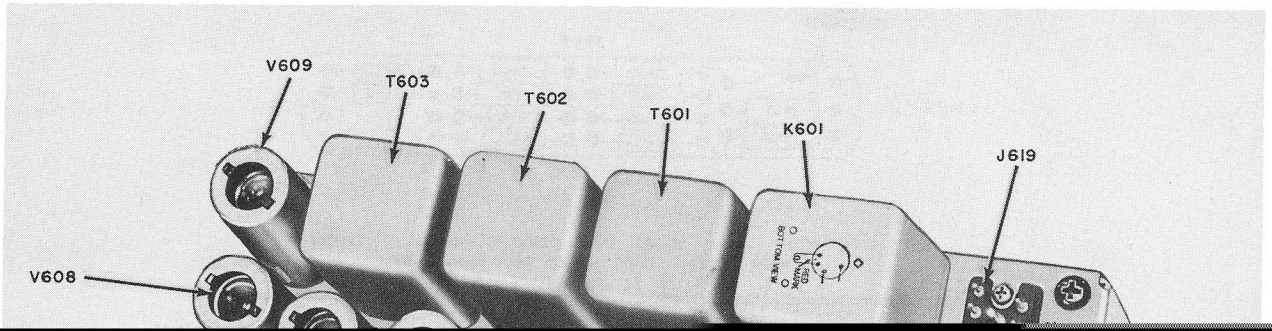

Figure 73. Vfo subchassis, sealed circuit cover removed.



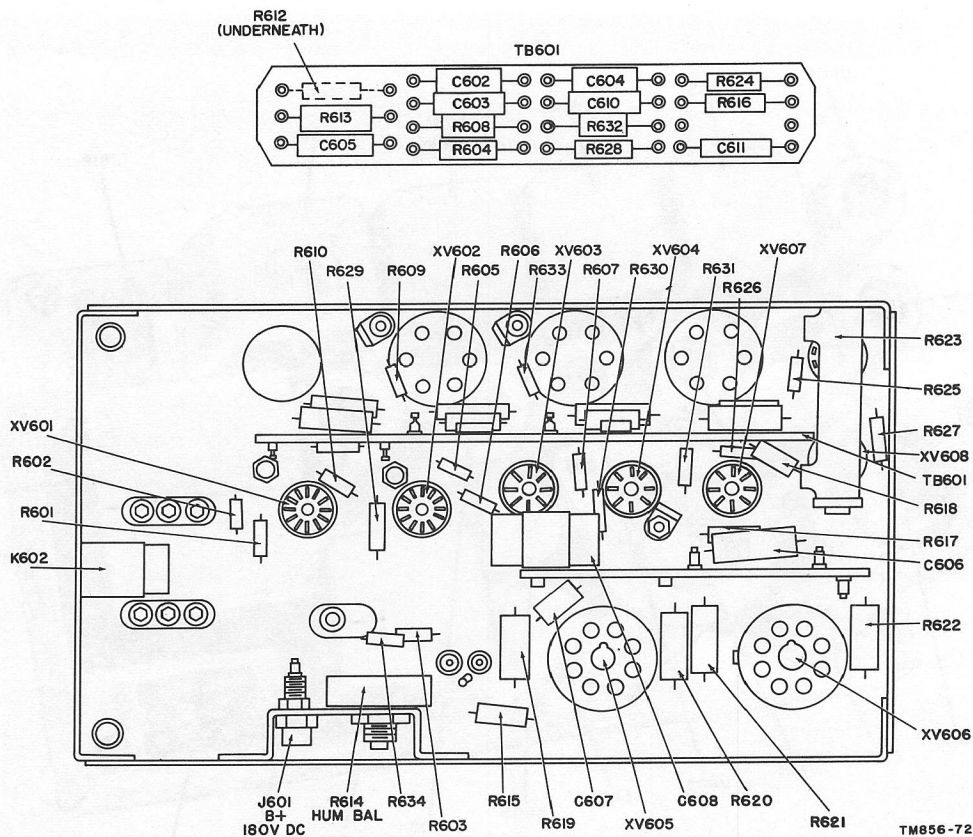

Figure 75. Af subchassis, bottom view.

contact of the plug. The voltage should measure approximately 2 to 3 volts ac for normal operation. When the trouble is in the vfo, check its tube (V701), check for loose coupling at the oscillator tuning shaft (par. 110*d*), and check the tube socket voltages. If no output signal is heard when the 2,455-kc unmodulated signal is applied to pin 7 of V205, check the third mixer, V205, and its tube socket voltages (fig. 82).

c. *Pin 1 of V204 (Plate of Second Mixer).* With the FUNCTION switch at MGC, apply the modulated 2-mc signal to pin 1 of tube socket XV204 (fig. 64). A weak output signal may indicate that plate resonant circuits Z222, Z223, and Z224 are not synchronized with the other tuning circuits (par. 110*a*) or are not individually aligned correctly.

d. *Pins 6 and 7 of V204 (Grid and Cathode of Second Mixer).* Apply a 10-mc modulated signal to test point E209 (fig. 62). If no output signal is audible, either the second mixer stage or the second crystal oscillator stage is defective. To determine which stage is at fault, apply a strong,

12-mc unmodulated signal to pin 7 while the antenna terminals are connected to an antenna or to a 2-mc signal source. The reception of static or signal when the 12-mc signal is applied indicates a faulty second crystal oscillator. Check for injection voltage from the second crystal oscillator by measuring the dc voltage with the vtvm at test point E209 (fig. 62), with the FUNCTION switch at STAND BY. A reading of -3 to -11 volts indicates that injection voltage is available from the second crystal oscillator. The amount of injection voltage available is determined by disconnecting P222 from J422 (fig. 86) and measuring the voltage at the contact of J422, using the ac probe of the multimeter. A reading of approximately 2 to 3 volts ac indicates normal output from the second crystal oscillator. If normal output is not obtained, test tube V402, the tube socket voltages (fig. 82), the alignment of the oscillator circuits, and the oscillator crystals (par. 100). Check synchronization (par. 110). If a crystal is defective, the band or bands associated with that crystal will be inoperative. If no output is heard

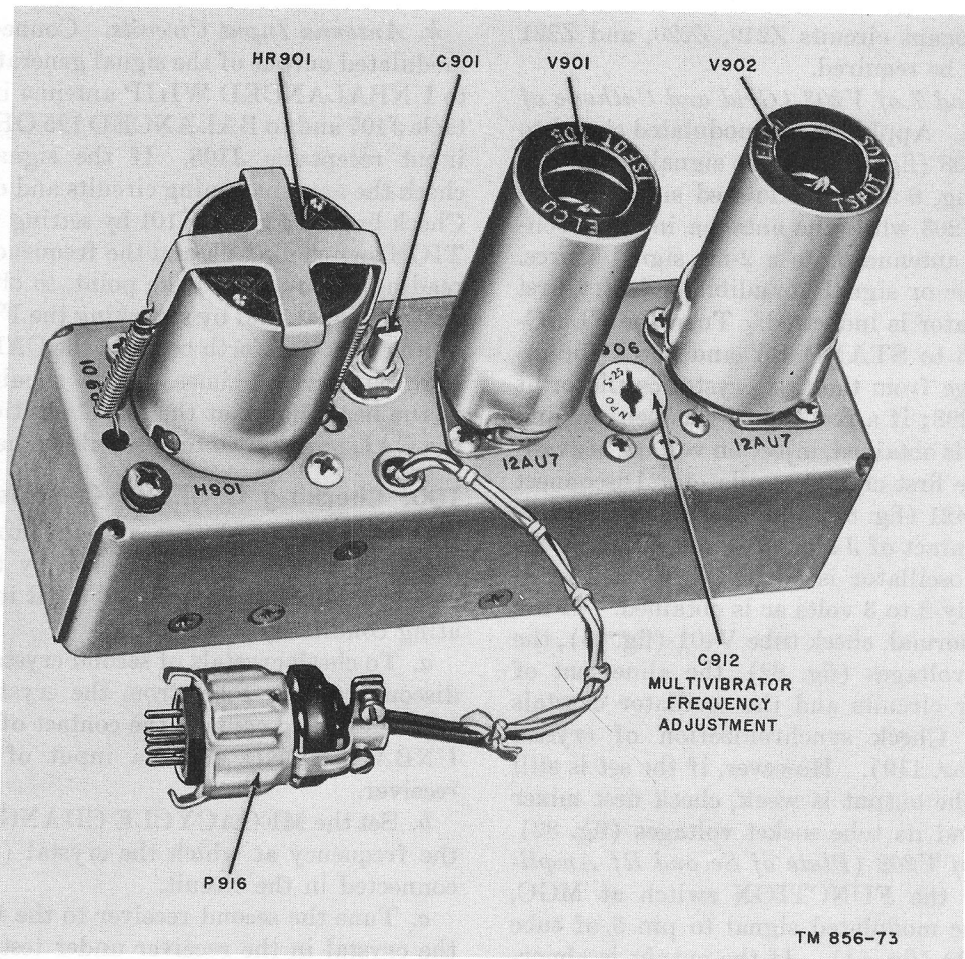

TM 856-73

Figure 76. Calibration-oscillator subchassis, top view.

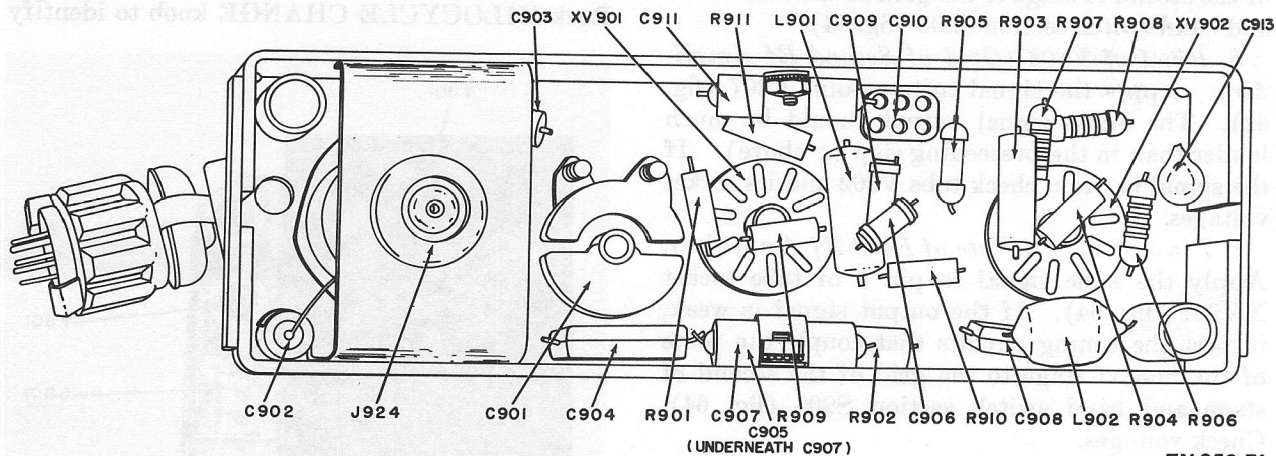

TM 856-74

Figure 77. Calibration-oscillator subchassis, bottom view.

when the signal is applied to pin 7, check second mixer V204 and its tube socket voltages (fig. 82).

e. Pin 1 of V203 (Plate of First Mixer). With the FUNCTION switch at MGC, apply at 10-mc

modulated signal to pin 1 of tube socket XV203 (fig. 64). If the output signal is weak, check the synchronization of the first if. slug rack and the first if. can rack. Alinement of the individual

slugs for resonant circuits Z219, Z220, and Z221 (fig. 62) may be required.

*f. Pins 6 and 7 of V203 (Grid and Cathode of First Mixer).* Apply a 2-mc modulated signal to test point E208 (fig. 62). If no signal is audible, apply a strong, 8-mc unmodulated signal to terminal 7 of V203 while the antenna input is connected to an antenna or to a 2-mc signal source. Then, if static or signal is audible, a faulty first crystal oscillator is indicated. Turn the FUNCTION switch to STAND BY and check for injection voltage from the first crystal oscillator at test point E208; if a reading of between  $-3$  and  $-11$  volts dc is obtained, injection voltage is available from the first crystal oscillator. Disconnect P221 from J421 (fig. 86) and measure the ac voltage at the contact of J421. The output from the first crystal oscillator is normal if a reading of approximately 2 to 3 volts ac is obtained. If the output is abnormal, check tube V401 (fig. 65), the tube socket voltages (fig. 82), the alinement of the oscillator circuits and the oscillator crystals (par. 100). Check synchronization of crystal oscillator (par. 110). However, if the set is still dead, or if the output is weak, check first mixer tube V203 and its tube socket voltages (fig. 82).

*g. Pin 5 of V202 (Plate of Second Rf Amplifier).* With the FUNCTION switch at MGC, apply a 2-mc modulated signal to pin 5 of tube socket XV202 (fig. 64). If the output is abnormal, check the tuning circuits that couple the plate of the second rf stage to the grid of the first mixer and band switch section S208 (fig. 64).

*h. Pin 1 of V202 (Grid of Second Rf Amplifier).* Apply the signal to test point E207 (fig. 62). The audic signal output should be much louder than in the preceeding step (*g* above). If the signal is weak, check tube V202 and its socket voltages.

*i. Pin 5 of V201 (Plate of First Rf Amplifier).* Apply the 2-mc signal to pin 5 of tube socket XV201 (fig. 64). If the output signal is weak, inspect the tuning circuits that couple the plate of the first rf stage to the grid of the second rf stage and band switch section S206 (fig. 64). Check voltages.

*j. Pin 1 of V201 (Grid of First Rf Amplifier).* Apply the 2-mc modulated signal to test point E206 (fig. 62). The output signal should be louder than that obtained in the preceding step (*i* above). If the signal is weak, test tube V201 and its socket voltages (fig. 82).

*k. Antenna Input Circuits.* Connect the 2-mc modulated output of the signal generator, in turn, to UNBALANCED WHIP antenna input receptacle J107 and to BALANCED 125 OHM antenna input receptacle J108. If the signal is weak, check the antenna tuning circuits and connections. Check break-in relay K101 by setting the FUNCTION switch at CAL and the frequency-indicator reading at an even 100-kc point, to obtain a calibration signal, and by switching the FUNCTION switch back and forth between the CAL and MGC positions several times. Tone should be heard in the headphones at the MGC position, while at the CAL position no tone should be heard.

## 100. Checking Oscillator Crystals

If it is suspected that an oscillator crystal is faulty, it can be readily checked by the use of a second Radio Receiver R-390/URR in good operating condition, as follows:

*a.* To check crystals of second crystal oscillator, disconnect plug P222 from the crystal-oscillator subchassis, and connect the contact of J422 to the UNBALANCED antenna input of the second receiver.

*b.* Set the MEGACYCLE CHANGE control to the frequency at which the crystal (par. 103) is connected in the circuit.

*c.* Tune the second receiver to the frequency of the crystal in the receiver under test, and set its BFO switch to ON. An audible signal should be heard in a headset connected to PHONES jack. Rock KILOCYCLE CHANGE knob to identify

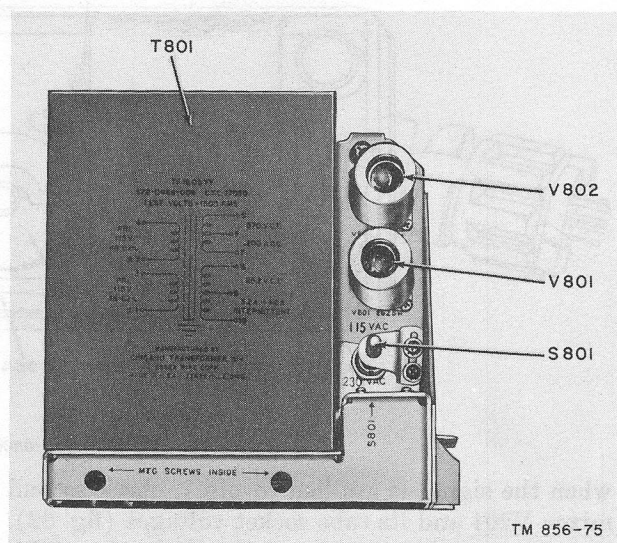
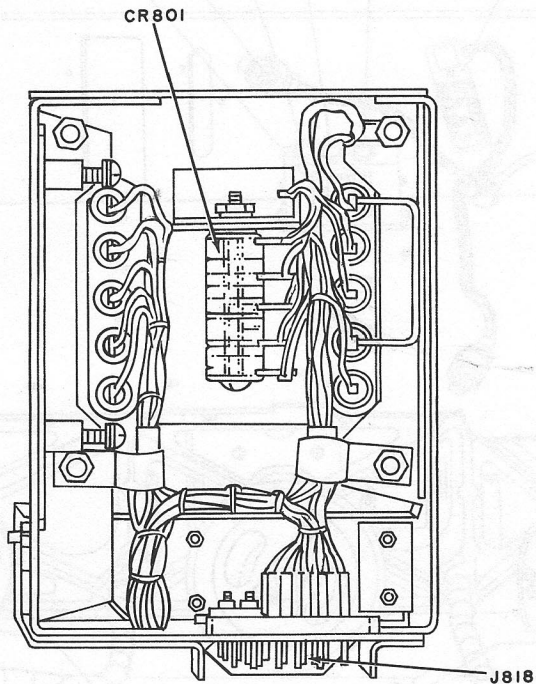
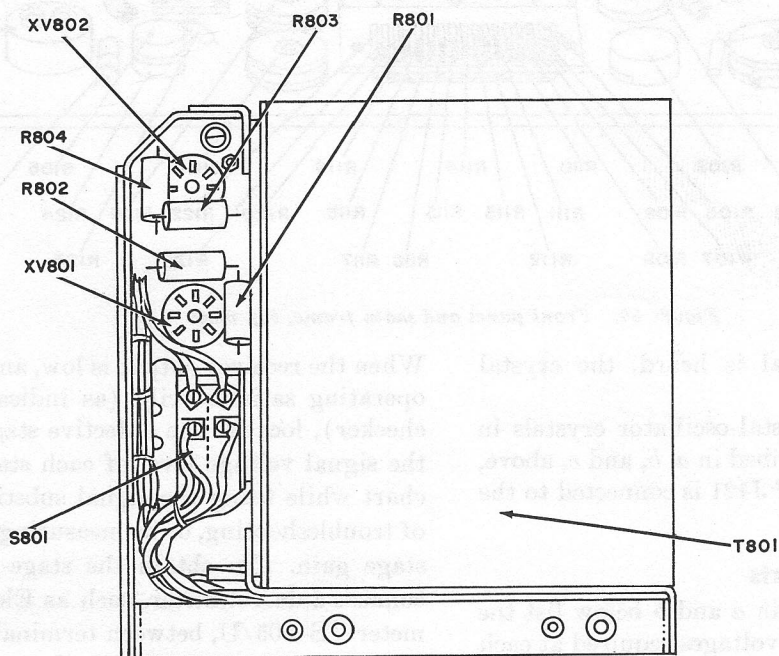

Figure 78. Power Supply PP-621/URR, top view.



BOTTOM VIEW



SIDE VIEW

TM 856-76

Figure 79. Power Supply PP-621/URR, bottom and side views.

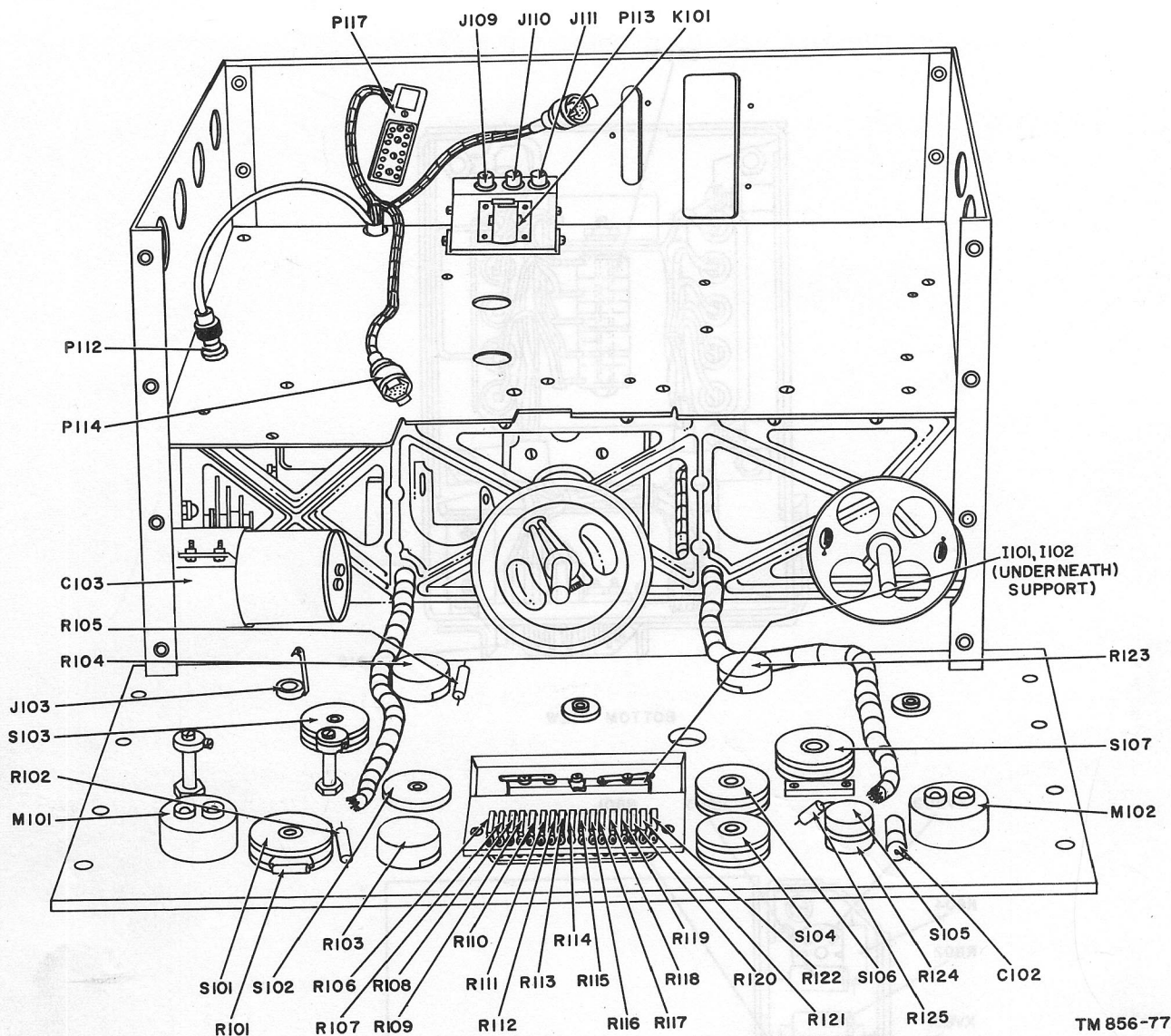

TM 856-77

Figure 80. Front panel and main frame, top view.

the signal. If no signal is heard, the crystal should be replaced.

d. Check the first crystal-oscillator crystals in the same manner as described in *a*, *b*, and *c*, above, except that the contact of J421 is connected to the second receiver.

### 101. Stage Gain Charts

The stage gain charts in *a* and *b* below list the minimum and maximum voltages required at each of the rf and if. stages of the receiver to produce a voltage of  $-7$  volts dc across the diode load. Use these charts as a standard when troubleshooting to check the overall gain of the receiver and the gain of each rf or if. stage or group of stages.

When the receiver output is low, and the tubes are operating satisfactorily (as indicated by a tube checker), localize the defective stage by checking the signal voltage level of each stage against the chart while using the signal substitution method of troubleshooting, or by measuring the individual stage gain. To obtain the stage-gain readings, connect a dc voltmeter, such as Electronic Multi-meter TS-505/U, between terminals 14 (DIODE LOAD) and 16 (GND) of the terminal strip on the back of the receiver (fig. 22). Terminal 14 must be jumpered to terminal 15. Connect the ground lead of the rf signal generator to the receiver ground, and connect the generator output

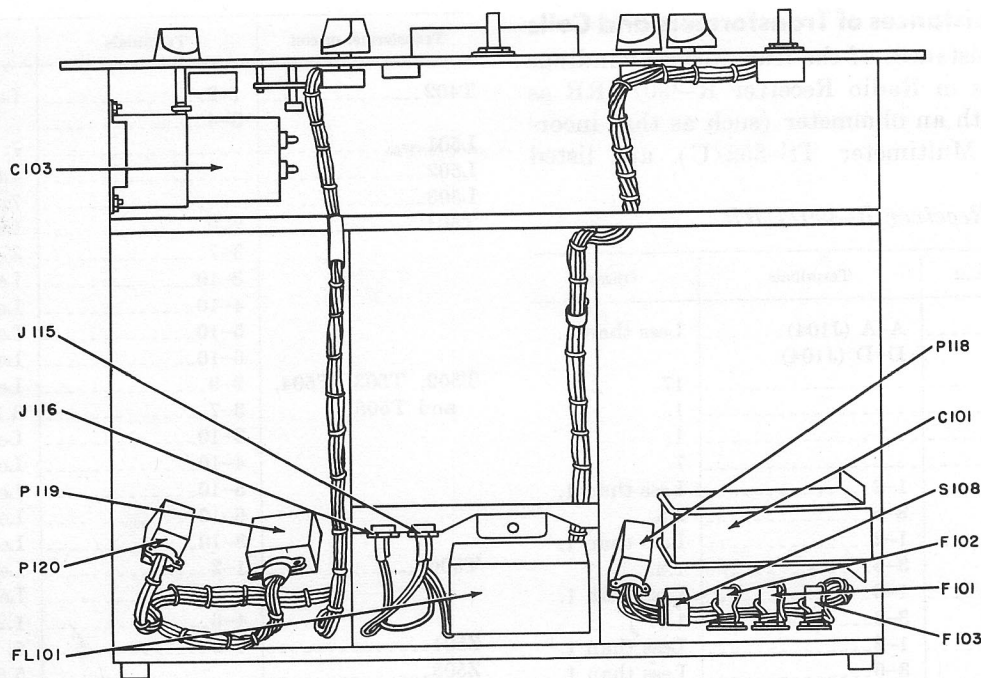

TM 856-78

Figure 81. Front panel and main frame, bottom view.

lead through a  $.1\text{-}\mu\text{f}$  capacitor to the receiver points indicated in the chart. When checking the 455-kc if. stages, access to the injection points can be gained by operating the subchassis outside the receiver, using the extension cables (par. 86), or by inserting a short length of wire into the tube socket terminal (par. 88a). Check the output from the signal generator required to obtain the

diode-load reference voltage of  $-7$  volts dc against the figures given in the charts. The lowest figure is the minimum and the highest is the maximum that should be required over the specified frequency range for normal operation. However, a reading that is slightly outside this range does not necessarily indicate improper functioning.

*a. Rf Subchassis Stages.*

Signal generator output connection	Balanced ant.	Test point E206 (1st rf grid V201)	Test point E207 (2d rf grid V202)	Test point E208 (1st mixer grid V203)		Test point E209 (2d mixer grid V204)			Test point E210 (3d mixer grid V205)	
				.5-8	9-18	9-18	3-2	8-32	3-2	.455
Frequency (mc) .....	.5-32	.5-32	.5-32	.5-8	9-18	9-18	3-2	8-32	3-2	.455
Signal generator output (microvolts).	1-4	4-16	28-78	40-62	36-53	43-59	23-28	41-71	92-117	22-50

*b. If. Subchassis Stages.*

Signal generator output connection	Signal generator output (microvolts)			
	2-ke bandwidth	4-ke bandwidth	8-ke bandwidth	16-ke bandwidth
1st if. grid V501 .....	130 to 180			
2d if. grid V502 .....	1,500 to 1,900	1,400 to 2,000	880 to 1,400	860 to 1,700
3d if. grid V503 .....	2,300 to 5,000	3,000 to 5,000	1,100 to 2,000	770 to 1,300
4th if. grid V504 .....	7,000 to 12,000	7,000 to 11,500	6,000 to 8,700	5,200 to 7,600
5th if. grid V505 .....	16,000 to 20,000	16,000 to 18,000	23,000 to 28,000	32,000 to 38,000
6th if. grid V506 .....	420,000 to 500,000	420,000 to 500,000	420,000 to 500,000	420,000 to 500,000



## 102. Dc Resistances of Transformers and Coils

The dc resistances of the transformer windings and the coils in Radio Receiver R-390/URR as measured with an ohmmeter (such as that incorporated in Multimeter TS-352/U) are listed below:

### a. Radio Receiver R-390/URR.

Transformer or coil	Terminals	Ohms
FL101	A-A (J104) D-D (J104)	Less than 1.
K101		17.
L242		1.
L243		1.
L246		7.
T201	1-2 3-6	Less than 1. 2.5.
T202	1-2 3-6	Less than 1. 1.8.
T203	1-2 3-6	Less than 1. 1.1.
T204	1-2 3-6	Less than 1. Less than 1.
T205	1-2 3-6	Less than 1. Less than 1.
T206	1-2 3-6	Less than 1. Less than 1.
T207	1-5 2-4	2.8. 4.5.
Z201		2.4.
Z202		1.9.
Z203		1.1.
Z204		Less than 1.
Z205		Less than 1.
Z206		Less than 1.
Z207		2.4.
Z208		1.8.
Z209		1.
Z210		Less than 1.
Z211	1-3	Less than 1.
Z212		Less than 1.
Z213		2.5.
Z214		1.8.
Z215		1.1.
Z216		Less than 1.
Z217		Less than 1.
Z218		Less than 1.
Z219		Less than 1.
Z220	Less than 1	
Z221	Less than 1	
Z222		1.6.
Z223		1.6.
Z224		1.6.
L401		7.
L402		7.
L403		1.
L404		1.
L405		1.
L406		7.
T401	1-2 3-4	Less than 1. Less than 1.

Transformer or coil	Terminals	Ohms
T402	1-2 3-4	Less than 1.
L501		7.
L502		4.5.
L503		7.
T501	2-9 3-7 3-10 4-10 5-10 6-10	Less than 1. 3.1. Less than 1. Less than 1. Less than 1. Less than 1.
T502, T503, T504, and T505.	2-9 3-7 3-10 4-10 5-10 6-10 8-10	Less than 1. 3.1. Less than 1. Less than 1. Less than 1. Less than 1. Less than 1.
T506	1-2 1-9 4-6	Less than 1. Less than 1. 1.2.
Z501	1-2	5.
Z503		5.5.
Z502	C532 through coil to pin 7 of V508. Pin 7 of V508 through coil to gnd.	1.7. Less than 1
FL601	IN-OUT IN-Gnd OUT-Gnd	50. 24. 24.
FL602	IN-OUT IN-Gnd OUT-Gnd	37. 230. 250.
K601	4-5	10K.
K602	3-4	8.
L601		90.
T601	1-2 3-4 5-6	850. 24. 26.
T602* and T603*	1-2 3-4 5-6	850. 24. 26.
L901		Less than 1.
L902		7.

\*Readings taken with speaker disconnected.

### b. Power Supply PP-621/URR.

Transformer or coil	Terminals	Ohms
T801	1-2 3-4 5-6 6-7 5-7 8-9 9-10 8-10	Less than 1. Less than 1. 25. 25. 50. Less than 1. Less than 1. Less than 1.

### 103. Rf and Variable If. Conversion Scheme

In order that the frequency conversion scheme of Radio Receiver R-390/URR may be easily understood, the chart is provided below. The frequency range of the second variable if. is from 2.5 to 2.0 mc for the .5- to 1.0-mc band, and from 3.0 to 2.0 mc for all other bands. The frequency range of the vfo is 3.455 to 2.455 mc for all bands. The fixed output if. of the third mixer is 455 kc. The following is an example of the use of the chart.

Frequency of station being received..... 5.5 mc  
 Frequency indicator reading..... 05 500  
 Band..... 5-6  
 Position of switch S201..... 4

Frequency range of antenna and rf coils... 4-8 mc  
 Position of switch S401..... 5  
 First crystal-oscillator crystal frequency... 8 mc  
 First crystal-oscillator output frequency... 8 mc  
 First variable if..... 13.5 mc

*Note.* The first variable if. equals the first crystal oscillator output frequency plus the frequency of the signal received.

Second crystal-oscillator frequency..... 8 mc  
 Second crystal-oscillator output frequency 16 mc  
 Second variable if..... 2.5 mc

*Note.* The second variable if. equals the difference frequency between the second crystal oscillator output frequency and the first variable if.

Vfo frequency..... 2.955 mc

*Note.* The vfo frequency equals the second variable if. plus the fixed if. output of the third mixer.

Third mixer fixed if. output..... 455 kc

Band (mc)	Position of switch S201	Range of antenna and rf coils (mc)	Position of switch S401	1st xtal-osc crystal freq (mc)*	1st xtal-osc output freq (mc)*	1st variable if. range (mc)*	2d xtal-osc crystal freq (mc)	2d xtal-osc output freq (mc)
0.5-1	1	0.5-1	0	9	9	9.5-10	12	12
1-2	2	1-2	1	8	8	9-10	12	12
2-3	3	2-4	2	10	10	12-13	15	15
3-4	3		3	12.6	12.6	15.6-16.6	6.2	18.6
4-5	4	4-8	4	7	7	11-12	14	14
5-6			5	8	8	13-14	8	16
6-7			6	9	9	15-16	9	18
7-8			7	10	10	17-18	10	20
8-9	5	8-16	8				11	11
9-10			9				12	12
10-11			10				13	13
11-12			11				14	14
12-13			12				15	15
13-14			13				8.0	16
14-15			14				8.5	17
15-16			15				9.0	18
16-17	6	16-32	16				9.5	19
17-18			17				10	20
18-19			18				10.5	21
19-20			19				11	22
20-21			20				11.5	23
21-22			21				12	24
22-23			22				12.5	25
23-24			23				13	26
24-25			24				9	27
25-26			25				14	28
26-27			26				9.666	29
27-28			27				10	30
28-29			28				10.333	31
29-30			29				10.666	32
30-31			30				11	33
31-32			31				11.333	34

\*Not in use after first eight frequency bands.

Figure 82. Radio Receiver R-390/URR, tube voltage and resistance and subchassis receptacle resistance diagram, top deck.

(Contained in separate envelope)

Figure 83. Radio Receiver R-390/URR tube, voltage and resistance and subchassis receptacle resistance diagram, bottom deck.

(Contained in separate envelope)

Figure 84. Radio Receiver R-390/URR, terminal boards voltage and resistance diagram.

(Contained in separate envelope)

## 104. B+ Voltage Distribution

The input voltage from the power line to the power supply is controlled by FUNCTION switch S107 (figs. 21 and 52). In addition, this switch also controls the application of B+ to the various circuits, with the exception of the first and second crystal oscillators and the vfo (fig. 98). B+ is always connected to these circuits, so that the temperature of the components will remain constant. In the MGC and the AGC positions of S107, regulated B+ voltage is applied to all circuits of the

receiver except the calibration oscillator and the squelch circuit (fig. 98). In the CAL position of the switch, the plate circuit of the calibration oscillator is energized, and the dc output of the dry-disk rectifier is applied to the antenna relay (fig. 56). In the SQUELCH position, B+ is connected to all receiver circuits as well as to the plate circuit of the squelch tube, section B of V601 (fig. 98). In the STAND BY position, all B+ circuits except to the oscillators are disconnected, and dc voltage is applied to the antenna relay (figs. 56 and 98).

## Section II. REPAIRS

### 105. Removals and Replacements

Directions for removing and replacing the subchassis and various detail parts of the receiver for bench testing or repair are contained in *a* through *t* below. All the subchassis, except the rf, can be removed from the receiver without prior removal of any of the other assemblies. While the rf, if., and vfo subchassis are outside the receiver, avoid changing the positions of the KILOCYCLE CHANGE, bfo, and vfo tuning shafts, if possible. Disturbing the positions of these shafts necessitates synchronization. Make any necessary presettings of the receiver controls, where possible, before removing the subchassis. Subchassis mounting screws are color-coded with green heads. In most cases these are captive screws, and need be loosened only until they are free of the main frame to remove the subchassis. When replacing the subchassis, the captive screws should first be started one at a time to locate the subchassis before tightening the screws all the way. The reference designations of the coaxial plugs are marked on bands fastened to the cables, near the plugs. To remove a coaxial plug, press the plug in slightly and twist counterclockwise to release; then pull the plug straight out. Where coaxial plugs are not readily accessible, scissors-type Tube Puller TL201, supplied with Tool Set TE-41, can be used. To remove 7-pin plugs P113, P114, P715, and P916, first twist the metal shell slightly counterclockwise to release the clamp, then pull the plug. Make sure that the pins are properly aligned with the jack contacts when replacing multi-contact plugs; the pins are easily bent. When loosening the clamp screws, be careful not to overdraw the screws; this will cause

the nut to drop off. Do not tighten clamp screws too far; the threads may be stripped. Make sure that the Bristo wrench is fully inserted into the screw to avoid stripping the slots in the head.

*a. Removal of Front Panel* (figs. 21 and 80). To gain access to the wiring and parts on the back of the front panel, or to prepare for removal of the rf subchassis, remove the front panel and proceed as follows:

- (1) Remove the top and bottom dust covers from the receiver.
- (2) Remove the two handles from the front panel by removing the nuts and washers that secure the handles at the rear of the panel.
- (3) Place wooden blocks under the side plates of the receiver main frame, in back of the front panel, so that the panel is clear of the bench and the receiver tilted backward.
- (4) Rotate the MEGACYCLE CHANGE and KILOCYCLE CHANGE control knobs fully counterclockwise to the home stop position.
- (5) Position the ANT. TRIM control at -4, and remove the knob.
- (6) Position the BFO PITCH control at 0. Position the BANDWIDTH control at 16 KC. Loosen the collars on the BANDWIDTH and BFO PITCH control shafts.
- (7) Remove the KILOCYCLE CHANGE and MEGACYCLE CHANGE control knobs.
- (8) Remove the DIAL LOCK and ZERO ADJ. knobs. Loosen the nut on the DIAL LOCK bushing and disengage the

lock from the KILOCYCLE CHANGE control locking disk (fig. 85).

- (9) Remove the four flat-head Phillips screws that secure the front panel to the main frame.
- (10) Remove the front panel by grasping the edges and drawing it straight out from the receiver. Replace the handles and place the panel face down on the bench, resting on the handles. Handle the panel carefully.

*b. Replacement of Front Panel.* To replace the front panel, reverse procedures in (1) through (10) above. When replacing the ZERO ADJ. knob, be sure that the threaded cap on the end of the shaft is rotated clockwise finger-tight. Place the knob on the shaft so that the spring-loaded movable part of the stop mechanism fits into the notch in the knob. Rotate the knob clockwise until the stop is reached. Allow the knob to rotate counterclockwise approximately one-sixteenth of an inch and tighten the set screw. If the bushings for the KILOCYCLE CHANGE and MEGACYCLE CHANGE controls have been moved, they should be loosened before the front panel is replaced and tightened after it is replaced. This helps to line them up and prevent binding of controls.

*c. Removal of Rf Subchassis* (figs. 21 and 85). To remove the rf subchassis, first disconnect coaxial connector P723 from J223 on the bottom deck of the receiver (fig. 88); use scissors-type tube puller TL201. Then remove the front panel as described in *a* above and proceed as follows:

- (1) Remove the green-coded offset gear from the upper left part of the rf gear plate and place it in mesh with the gear train as shown in figure 87.

*Note.* The offset gear is used to maintain synchronization of the gear train when the rf subchassis is removed from the receiver.

- (2) Disengage the following coaxial connectors on the top deck of receiver: P209 from J109, P210 from J110, P211 from J111, P221 from J421, P222 from J422, P224 from J924, P225 from J525, and P226 from J526. (It may be necessary to temporarily remove V501 and its shield to disengage this connector.)
- (3) Remove the dust cover from the top of the rf subchassis; then disconnect P114 from J214.

- (4) Rotate the KILOCYCLE CHANGE control shaft slightly counterclockwise to stop position. The frequency indicator reading should be 00-972. (Note minus sign.)
- (5) Remove the two green 1/2-inch, color-coded screws that secure the subchassis to the end plate of the main frame. Make sure that only these screws are used when replacing the subchassis.
- (6) Loosen the three green color-coded captive screws, two at the left-hand corners of the subchassis, and one in the upper right-hand corner.
- (7) Lift the subchassis up and out of the receiver, disengaging the Oldham coupler on the crystal-oscillator band switch shaft. The floating disk of the coupler will drop down; do not lose this disk. The subchassis should be placed on its side or on top of the test bench, but never in such a position that it is supported by the gear train that extends beyond the frame of the subchassis.

**Caution:** When the rf subchassis is removed from the receiver, the tension of the loading springs on the MEGACYCLE CHANGE control split gear and KILOCYCLE CHANGE control split gear (counter drive gear) (fig. 88) is relieved, allowing the springs to hang loosely from the gears. Remove the springs and place them in an envelope. The two loading springs of the KILOCYCLE CHANGE split gear are shorter than those of the MEGACYCLE CHANGE split gear.

*d. Replacement of Rf Subchassis* (figs. 85, 86, and 88). Before replacing the rf subchassis, check its synchronization (par. 110a). To replace, proceed as follows:

- (1) Loosen the front clamp that holds the KILOCYCLE CHANGE control locking disk (fig. 85) and move the disk forward.
- (2) Loosen the Oldham coupler clamp (fig. 86) on the crystal oscillator and move the coupler back.
- (3) To set the 10-turn stops, rotate the KILOCYCLE CHANGE and MEGACYCLE CHANGE control shafts fully counterclockwise.

- (4) Place the rf subchassis on the frame in the receiver and loosely tighten the rear left and rear right green mounting screws. Engage but do not tighten the front left green mounting screw.
- (5) Raise the front left side of the rf subchassis by placing a screwdriver between it and the main frame, near the if. subchassis.
- (6) Load the large brass split gear (fig. 87) two teeth. Pull out the screwdriver ((5) above). The intermediate gear will mesh with the pinion gear (fig. 88).
- (7) Tighten front and rear left green mounting screws.
- (8) Raise the front side of the rf subchassis with a screwdriver to disengage the driven gear (fig. 87) from the MEGACYCLE CHANGE control drive gear (fig. 85).

**Caution:** While performing the last step make sure that the intermediate gear does not disengage from the pinion gear ((6) above).

- (9) Load the MEGACYCLE CHANGE control drive gear two teeth.
- (10) Pull out the screwdriver ((8) above) and mesh the MEGACYCLE CHANGE control drive gear to the driven gear.
- (11) Insert the two green mounting screws on the right side of the frame.
- (12) To replace the KILOCYCLE CHANGE control locking disk, engage one-half of the counter drive gear (fig. 88); load the gears two teeth, and then engage the front half of the counter drive gear.
- (13) Remove the green-coded offset from the gear train and mount it in its position at the upper left part of the rf gear plate.
- (14) Tighten the front clamp on the KILOCYCLE CHANGE control locking disk.
- (15) To check the detent, rotate the MEGACYCLE CHANGE control fully clockwise. The stop must fall where the first two digits on the frequency indicator read approximately halfway between 31 and 32.
- (16) Set the MEGACYCLE CHANGE control so that the Oldham coupler (fig. 86) protrusion is horizontal. Slide on the re-

movable disk and mate the rear disk to the removable disk.

- (17) Check the reading on the crystal-oscillator band switch position indicator (fig. 65). See that it agrees with the reading on the megacycle portion of the frequency indicator. If it does not, turn the SYNC XTAL OSC control (fig. 22) until the two readings correspond.
- (18) Tighten the rear clamp on the Oldham coupler.
- (19) Reconnect the following coaxial connectors: P209, P210, P211, P221, P222, P224, P225, and P226.
- (20) Reconnect P114 with J214, and replace the dust cover over the rf subchassis.
- (21) Reconnect P723 with J223.
- (22) Replace the front panel (b above).
- (23) Recheck synchronization (par. 110a).
- (24) Check synchronization of the vfo tuning shaft (par. 110d).
- (25) Check alinement of the rf subchassis (pars. 114, 115, and 116).

*e. Removal of Crystal-Oscillator Subchassis* (fig. 86). To remove the crystal-oscillator subchassis, proceed as follows:

- (1) Remove the top dust cover of the receiver.
- (2) Disconnect plugs P113 from J413, P221 from J421, and P222 from J422, on the crystal-oscillator subchassis (fig. 65).
- (3) Remove the cover from the top of the subchassis.
- (4) Rotate the MEGACYCLE CHANGE control until the set screw in the clamp of the crystal-oscillator band switch coupler is accessible. Loosen the set-screw and push back the flange.
- (5) Remove the two, green,  $\frac{5}{16}$ -inch color-coded screws that secure the subchassis to the rear panel of the receiver. When replacing the subchassis, make sure that only these screws are used, because longer screws can cause a short circuit in the crystal-oscillator subchassis.
- (6) Loosen the two green captive screws inside the subchassis, one near tube V401 and the other near the point where the switch shaft enters the subchassis.
- (7) Lift the subchassis straight up from the receiver. The floating disk of Oldham coupler will drop down; do not lose it.

*f. Replacement of Crystal-Oscillator Subchassis.* To replace the crystal-oscillator subchassis, proceed as follows:

- (1) Lightly coat the coupler flange on the crystal-oscillator band switch drive shaft (located on the rf subchassis) with grease. Place the floating disk against the grease-coated surface of the flange. Grease will hold the disk in place until the flanges of the couplers are mated.
- (2) Lower the subchassis carefully into place and start the two green color-coded captive screws.
- (3) Replace the  $\frac{5}{16}$ -inch green captive screws in the back panel; tighten the screws.
- (4) See that the ridges on the coupler flanges are positioned  $90^\circ$  apart, and that the number showing on the crystal-oscillator band switch position indicator (below J422) agrees with the megacycle reading on the frequency indicator. Mate the flanges and secure the clamp.
- (5) Complete the replacement by performing the procedure described in (3), (2), and (1) (in that order) of *e* above.
- (6) Check synchronization of the crystal oscillator (par. 110).

*g. Removal of If. Subchassis* (fig. 86). To remove the if. subchassis, proceed as follows:

- (1) Remove the top dust cover of the receiver.
- (2) Rotate the BANDWIDTH control to gain access to the clamp that secures the control shaft in back of the panel is accessible. Make a note of the control position.
- (3) Set the BFO PITCH at 0.
- (4) Loosen the clamp set screws on the BANDWIDTH and BFO PITCH control shafts, and uncouple the shafts by pulling outward on the control knobs.
- (5) Disconnect coaxial connectors P225 from J525, P226 from J526 and P112 from J512 on top of the if. subchassis (fig. 68).
- (6) Disconnect plug P117 from J517 (fig. 68).
- (7) Loosen the three green captive screws, one at the front-center of the subchassis and two at rear corners.
- (8) Lift the subchassis straight up from the receiver. Do not disturb the positions of the BANDWIDTH and BFO PITCH tuning shafts after the subchassis is re-

moved from receiver, unless necessary for performing tests.

*h. Replacement of If. Subchassis.* To replace the if. subchassis, reverse procedures in (1) through (8) above. Before recoupling the BANDWIDTH and BFO PITCH control shafts, be sure that the controls are set at the positions noted during removal. Check the calibration of the bfo (par. 117).

*i. Removal of Power Supply PP-621/URR* (fig. 88). To remove the power supply subchassis, proceed as follows:

- (1) Remove the bottom dust cover from the receiver.
- (2) Disconnect large connector P118 from J818 (fig. 88).
- (3) Loosen the two captive screws, accessible through holes indicated by arrows marked MTG SCREWS INSIDE.
- (4) Loosen the green captive screw in the corner of the subchassis, near tube V802.
- (5) Remove the four, green,  $\frac{7}{16}$ -inch screws that secure the power transformer to the side of the main frame; make sure that only these screws are used when replacing the subchassis.
- (6) Lift the subchassis straight up from the receiver.

*j. Replacement of Power Supply PP-621/URR.* To replace the power supply subchassis, proceed in the reverse order of removal. When tightening the color-coded screws, start the screws in the following order: the one captive screw, the four  $\frac{7}{16}$ -inch screws, and the two hidden screws.

*k. Removal of Vfo Subchassis* (fig. 88). To remove the vfo subchassis, proceed as follows:

- (1) Remove the bottom dust cover of the receiver.
- (2) Disconnect plug P715, coaxial connector P723, J115, and J223 (fig. 88). Use scissors-type Tube Puller TL201 for removing P723.
- (3) Remove the small loading spring from the Oldham coupler on the vfo tuning shaft. *Do not lose the spring.*
- (4) Rotate the KILOCYCLE CHANGE control so that the ridge in the flange or the coupler nearest the vfo subchassis is vertical.

*Note.* If synchronization of the vfo tuning shaft and KILOCYCLE CHANGE control is to

be maintained, do not disturb the position of the shaft during the succeeding steps, or after the vfo subchassis has been removed.

- (5) Loosen the two green-coded captive screws in the front mounting bracket of the subchassis and the single color-coded captive screw in the rear bracket.
- (6) Carefully remove the subchassis from the receiver, lifting straight up to disengage the coupler, and then tilting slightly to clear the receiver. The floating disk will drop down from the coupler; do not lose it.

*l. Replacement of Vfo Subchassis.* To replace the vfo subchassis, proceed as follows:

- (1) If the position of the vfo tuning shaft has been disturbed while the subchassis was removed from the receiver, or if a new vfo is to be installed, synchronize the shaft as described in paragraph 110*d*.
- (2) If the position of the shaft has not been disturbed, place the floating disk on the flange of the vfo drive shaft (on the main frame). Position the ridge on the coupler flange of the vfo tuning shaft 90° from that of the flange on the drive shaft, and carefully insert the vfo subchassis into place, tilting it slightly to clear the receiver frame.
- (3) Tighten the three green color-coded screws on the subchassis mounting brackets.
- (4) Replace the loading spring on the coupler.
- (5) Connect P715 to J115 and P723 to J223 (fig. 88).
- (6) Replace the dust cover on the receiver.
- (7) If the vfo setting has been disturbed, refer to paragraph 110 for synchronization procedures.

*m. Removal of Calibration-Oscillator Subchassis* (fig. 88). To remove the calibration-oscillator subchassis, proceed as follows:

- (1) Remove the bottom dust cover from the receiver.
- (2) Disconnect plugs P715 from J115, P916 from J116 (fig. 88). Move the cable attached to P715 to free it of the subchassis.
- (3) Disconnect coaxial connector P224 from J924 on the top deck of the receiver (fig. 86).

- (4) Loosen the two green captive screws at opposite ends of the subchassis.
- (5) Carefully lift the subchassis out of the receiver.

*n. Replacement of Calibration-Oscillator Subchassis.* To replace the calibration-oscillator subchassis, proceed in the reverse order of removal.

*o. Removal of Af Subchassis* (fig. 88). To remove the af subchassis, proceed as follows:

- (1) Remove the bottom dust cover from the receiver.
- (2) Disconnect plugs P119 from J619 and P120 from J620 (fig. 88).
- (3) Remove the screw from the cable clamp that secures the cable at side of the af subchassis.
- (4) Loosen the screw in the clamp that secures the cable to the casting at the front end of the af subchassis, and swing the clamp free of the cable.
- (5) Loosen the three green color-coded captive screws, one at the front end of the subchassis and two at the rear corners.
- (6) Move the cable from which the clamps were removed, lift the subchassis straight up, and then tilt the front down slightly to remove the subchassis from the receiver.

*p. Replacement of Af Subchassis.* To replace the af subchassis, reverse the procedure described in *o* above.

*q. Removal of Rf Tuning Coils and Transformers* (fig. 62). To remove the rf tuning coils and transformers for voltage and resistance measurements at the sockets or banana-pin contacts, proceed as follows:

- (1) Remove the slug rack associated with the coil or transformer, by unhooking the spring located at each end of rack. Then use a bent paper clip hooked through the end of the spring to anchor the spring temporarily to the end plates of the subchassis. Be careful that the springs do not fly into the subchassis.
- (2) Insert a Phillips screwdriver, supplied with the receiver, into the two holes in the coil or transformer can, and loosen the screws until they are free of the subchassis.
- (3) Withdraw the coil or transformer from the subchassis.

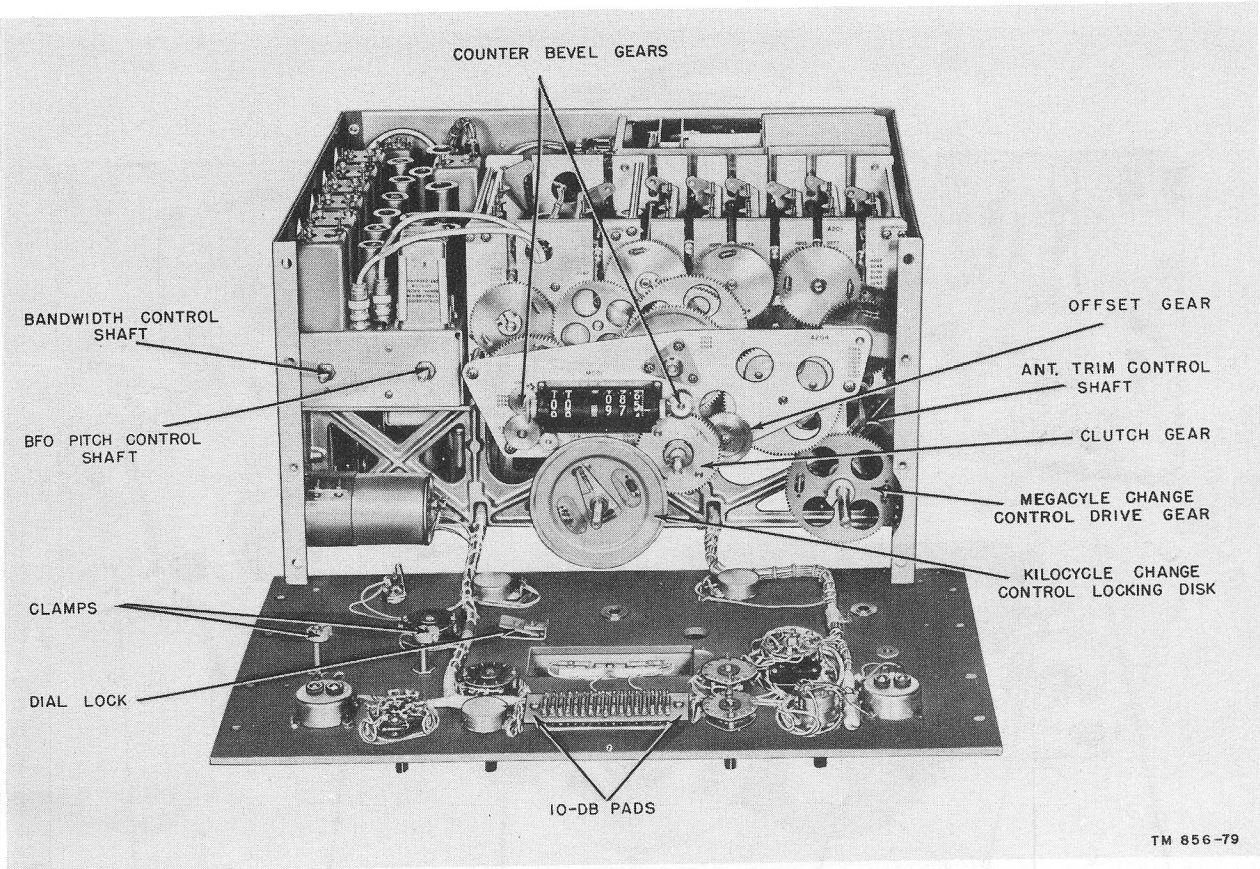

Figure 85. Radio Receiver R-390/URR, front panel removed.

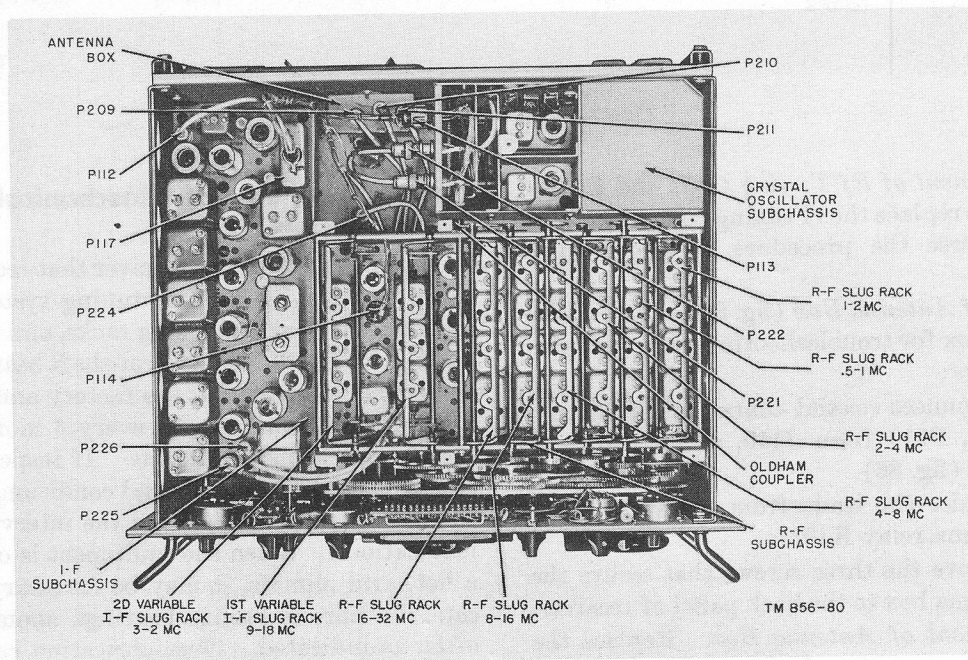

Figure 86. Radio Receiver R-390/URR, top view, dust cover and shields removed.



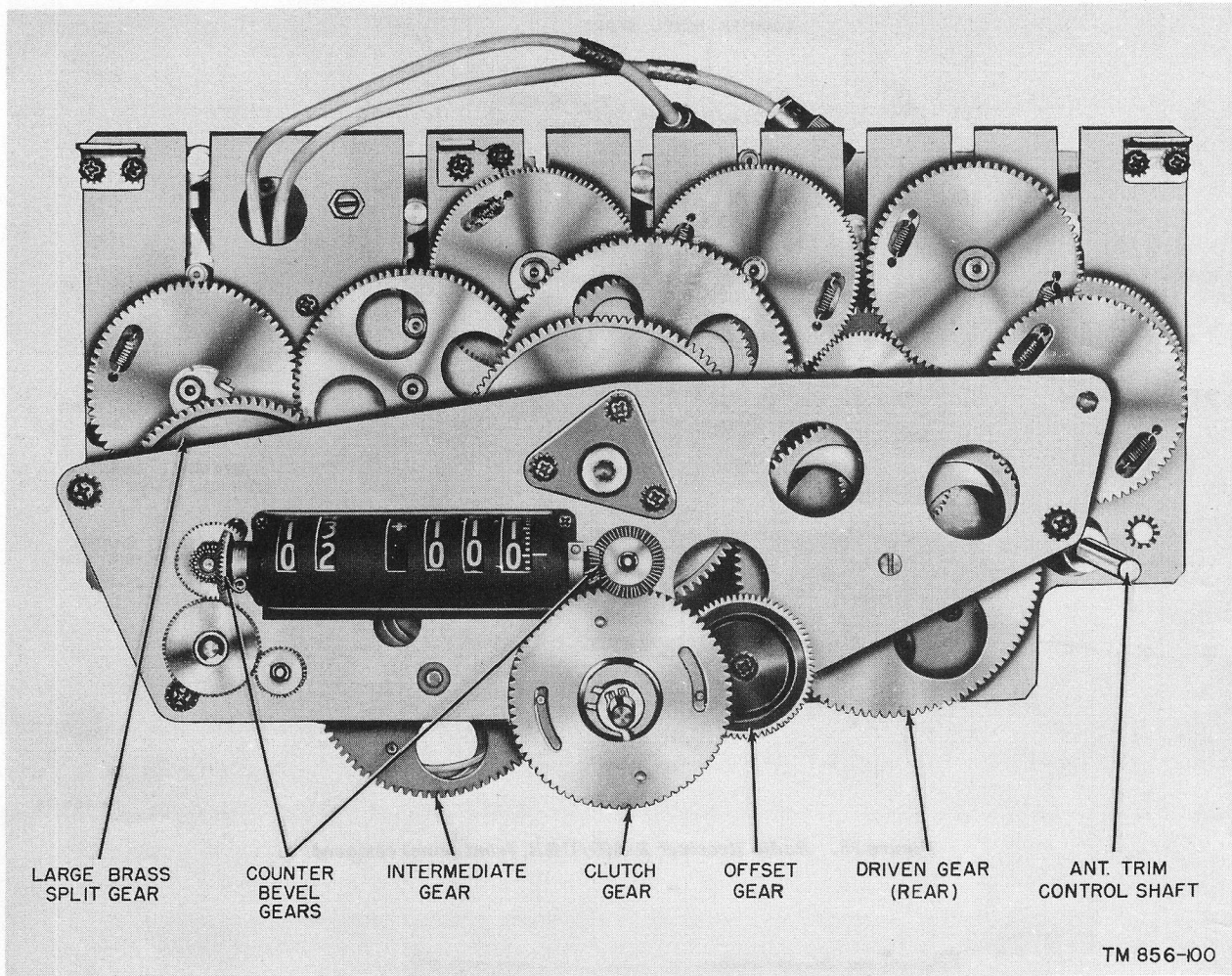

Figure 87. Location of gears.

r. *Replacement of Rf Tuning Coils and Transformers.* To replace the rf tuning coils and transformers, reverse the procedure described in q above.

s. *Removal of Antenna Box* (fig. 86). To remove the antenna box for troubleshooting or repair, proceed as follows:

- (1) Disconnect coaxial connector P209 from J109, P210 from J110, and P211 from J111 (fig. 86).
- (2) Unsolder the leads from the winding of antenna relay K101.
- (3) Remove the three screws that secure the antenna box to the back panel of receiver.

t. *Replacement of Antenna Box.* Replace the antenna box by reversing the procedure described in s above.

## 106. Lubrication of Mechanical Tuning System

The only parts of the receiver that require lubrication are the mechanical tuning system (which includes the gear train, slug racks, and cam rack), and the BFO PITCH control-shaft bearing. The receiver is lubricated at the factory and should be lubricated thereafter once every 6 months under normal operating conditions. If inspection indicates the need, or if abnormal conditions or activities are encountered, shorten the interval between lubrications. When the equipment is operated in a hot, arid climate, it may be necessary to lubricate the porous bronze bearings about twice as often as indicated. Overlubrication causes more harm than no lubrication. Check the condition of the mechanical tuning system whenever the re-

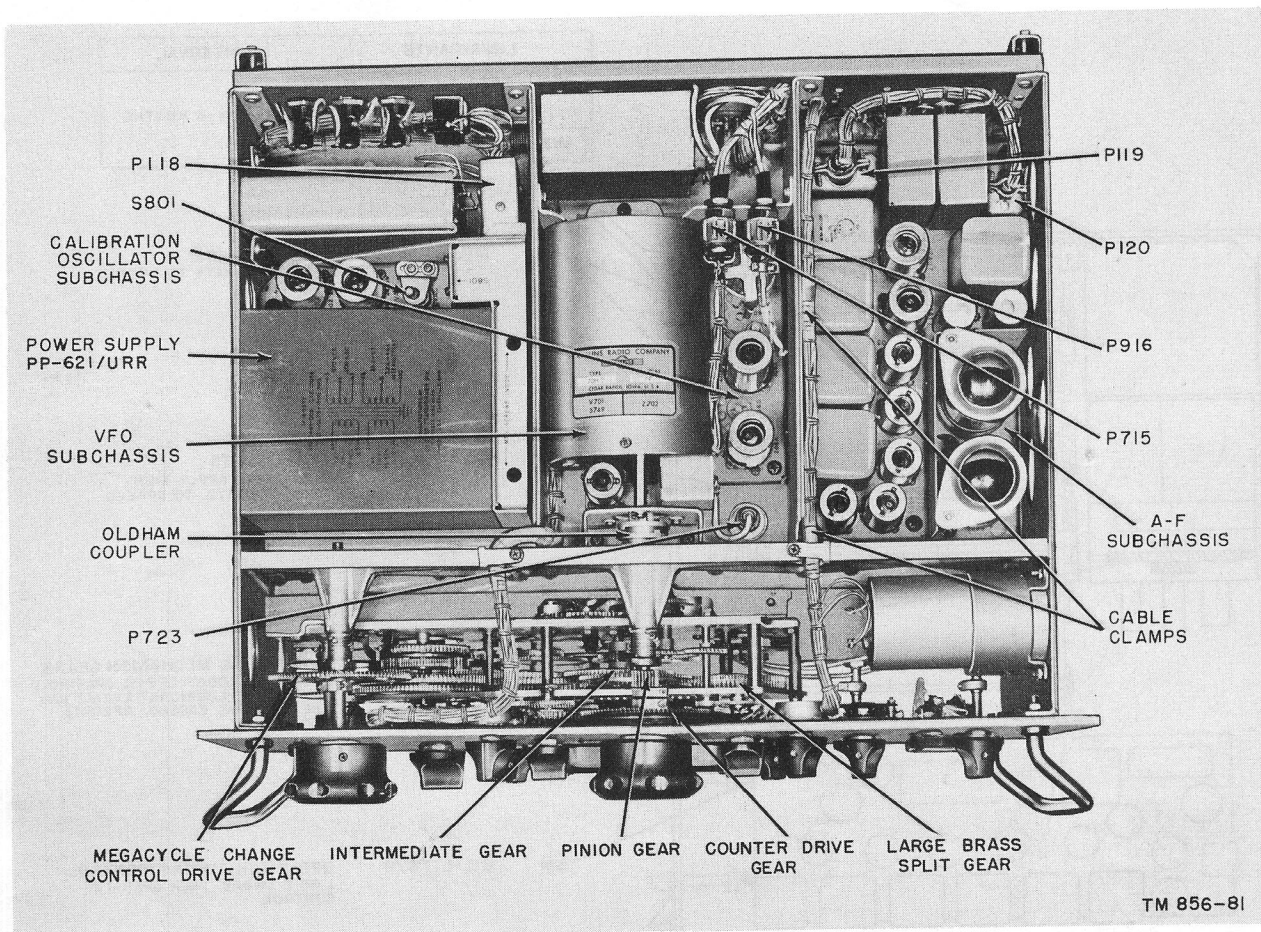

Figure 88. Radio Receiver R-390/URR, bottom view, dust cover removed.

ceiver is withdrawn from the case or rack for servicing. Manually rotate the MEGACYCLE CHANGE and KILOCYCLE CHANGE controls throughout their ranges, and note ease of operation. Check for lack of lubrication on gears, edges of cams, cam rollers, guide slots, and bearings; inspect for gritty grease and oil. Operate the BFO PITCH control; if operation is rough or uneven, check the lubrication of the control-shaft bearing.

**Caution:** Never attempt to lubricate the sealed oscillator (vfo), regardless of possible noisy operation of the unit during tuning. Unstable operation of the oscillator may result.

*a. Cleaning Before Lubrication.* Remove the covers from the rf and crystal-oscillator subchassis. Use a thin, long-handled brush with medium bristles, dipped in Solvent, Dry Cleaning (SD). Remove the dirt, oil, and grease from the

gears, cams, guide slots, and bearings. To gain access to all of the gear teeth while cleaning, rotate the MEGACYCLE CHANGE and KILOCYCLE CHANGE knobs. After dipping the brush in solvent (SD), remove the excess to prevent solvent from dripping onto connecting cables, wiring, or other electrical parts. Use a clean, lint-free cloth moistened with solvent (SD) to remove grease from the metal casting and chassis. Thoroughly wipe all parts with a clean, dry, lint-free cloth before proceeding with lubrication.

*b. Detailed Lubrication Instructions.* Lubricate the gear train, slug racks, and cam rack as indicated in figure 89. To apply oil to the bearings, dip a length of wire into the oil to collect a small drop at the end, and transfer the oil to the bearing by touching the end of the wire to the edge of the bearings. Avoid using excessive amounts of oil. A standard grease gun and a

LUBRICANTS	INTERVAL
MIL-L-7870-LUBRICATING OIL GENERAL PURPOSE, LOW TEMPERATURE	6M-6 MONTHS
MIL-G-7421-GREASE	

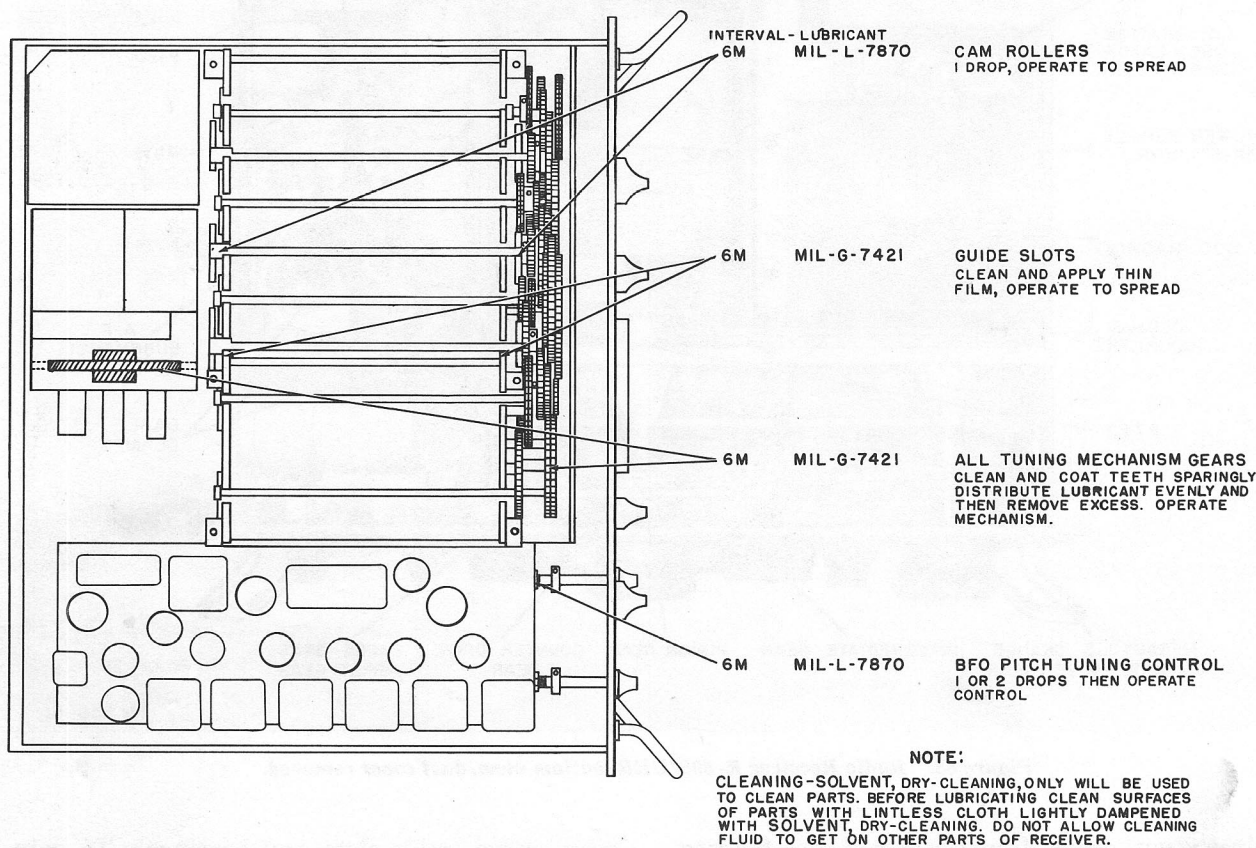

TM856-82

Figure 89. Lubrication of Radio Receiver R-390/URR.

thin, long-handled brush should be used for applying grease to gear teeth, edges of cams, and tuning rack guide slots. Rotate the MEGACYCLE CHANGE and KILOCYCLE CHANGE controls as necessary to expose all gear teeth.

### 107. Refinishing

Instructions for touchup painting are given in paragraph 40, and instructions for refinishing badly marred panels or an exterior cabinet are contained in TM 9-2851.

## Section III. ALINEMENT AND ADJUSTMENT PROCEDURES

### 108. Test Equipment and Tools Required for Alinement and Adjustment

*a. Signal Generator.* The signal generator must be an accurately calibrated instrument such as RF Signal Generator Set AN/URM-25, capable of producing rf signals within a frequency range of .455 to 32 mc. The attenuator must be capable of varying the output of signal generator

over a range of approximately 1 microvolt to 1 volt.

*b. Output Meter.* The output meter should be a vacuum-tube voltmeter, such as Electronic Multimeter TS-505/U, having a high resistance input. It must have a dc voltage range suitable for measuring 2 to 10 volts, and a high-frequency probe for measuring 1 to 10 volts ac.

c. *Volt ohmmeter.* A volt ohmmeter is required for checking the synchronization of the crystal-oscillator band switch and line voltage measurements. Multimeter TS-352/U is suitable for this purpose.

d. *Vtvm.* A vacuum-tube voltmeter that has a .01- to .1-volt ac range, such as Electronic Multimeter ME-6/U, is required for performing the regulated voltage hum adjustment.

e. *Variable Autotransformer.* A variable autotransformer, such as Transformer CN-16/U, is required for performing the regulated-voltage hum adjustment.

f. *Resistors.* Two 68-ohm, a 75-ohm, and a 95-ohm, noninductive,  $\frac{1}{4}$ -watt resistors must be available for connecting RF Signal Generator AN/URM-25 to the balanced antenna input when aligning the rf subchassis.

g. *Tools.* A bakelite alinement tool is required for adjusting transformer cores and trimmer capacitors. The No. 8 Bristo wrench and the Phillips screwdriver supplied with the receiver are required for adjustments during synchronization of the tuning shafts.

*Note.* Before performing the alinements, allow the receiver to warm up for 1 hour.

## 109. Regulated-Voltage Hum Adjustment

If objectionable hum is noted in the output of the receiver, adjust the regulated voltage for minimum hum as follows:

a. Connect Power Cable Assembly CX-1358/U between the receiver and a variable autotransformer, such as Transformer CN-16/U.

b. Connect a voltmeter (such as Multimeter TS-352/U), set at 100- to 200-volt ac range, across the output of the autotransformer.

c. Connect the vtvm (such as Electronic Multimeter ME-6/U) set at .01- to .1-volt ac range, between B+ 180 VDC jack J601 and ground.

**Warning:** Avoid contact with the B+ 180 VDC jack when the receiver is turned on; the high voltage is present at this jack.

d. Be sure that the receiver is grounded; then connect the autotransformer to 115-volt, 60-cycle source.

e. Check to see that switch S801 on Power Supply PP-621/URR is set at the 115V position; then turn on the receiver and allow it to warm up.

f. Adjust the autotransformer for an accurate 115-volt line-voltage reading on the vtvm.

g. Insert the screwdriver in the slot of HUM BAL control R614 (fig. 75), which is accessible through the right side plate of the main frame, and adjust for minimum reading one Electronic Multimeter ME-6/U.

## 110. Mechanical and Electrical Synchronization

The receiver tuning shafts, consisting of the 6-position rf band switch shaft, slug-rack camshafts, crystal-oscillator band switch shaft, and the vfo tuning shaft, must be in synchronization with the gear train before attempting to aline the receiver. Follow the procedure given below.

a. *Camshafts.* The camshafts are synchronized properly if the index line etches on the rear plate of the rf subchassis bisect the holes in each of the rear cams (fig. 90) when the frequency-indicator reading is 02 000. To synchronize the rf subchassis when it is removed from the cabinet, rotate the large brass gear (in the center of the subchassis) and the clutch gear (fig. 87) to positions where the frequency-indicator reading is 02 000. If the index lines do not bisect the holes, follow the procedure outlined in (2) through (7) below. Before replacing the rf subchassis (par. 105d), rotate the two gears mentioned above to positions where the first two digits on the frequency indicator indicate halfway between 99 and 00, and the last three digits read -972. (Note the minus sign.) When the rf subchassis is in the cabinet, proceed as follows:

*Note.* The camshafts are secured to the drive gears by clamps at the hubs of the gears. To position a camshaft, loosen the clamp which (except for the 8-16-mc shaft) is located at the end of the individual shaft in front of the rf subchassis to avoid losing the nut. Do not loosen the clamp more than necessary. Be careful not to strip the screw thread.

- (1) Check the 10-turn stop by rotating the MEGACYCLE CHANGE and the KILOCYCLE CHANGE controls fully counterclockwise. The frequency indicator should read halfway between 99 and 00 (off detent position) and -972. (Note the minus sign.) Check the reading on the crystal-oscillator band switch position indicator to see that it agrees with the reading on the megacycle portion of the frequency indicator. If it does not agree, loosen the Oldham coupler clamp (fig. 86) on the crystal oscillator

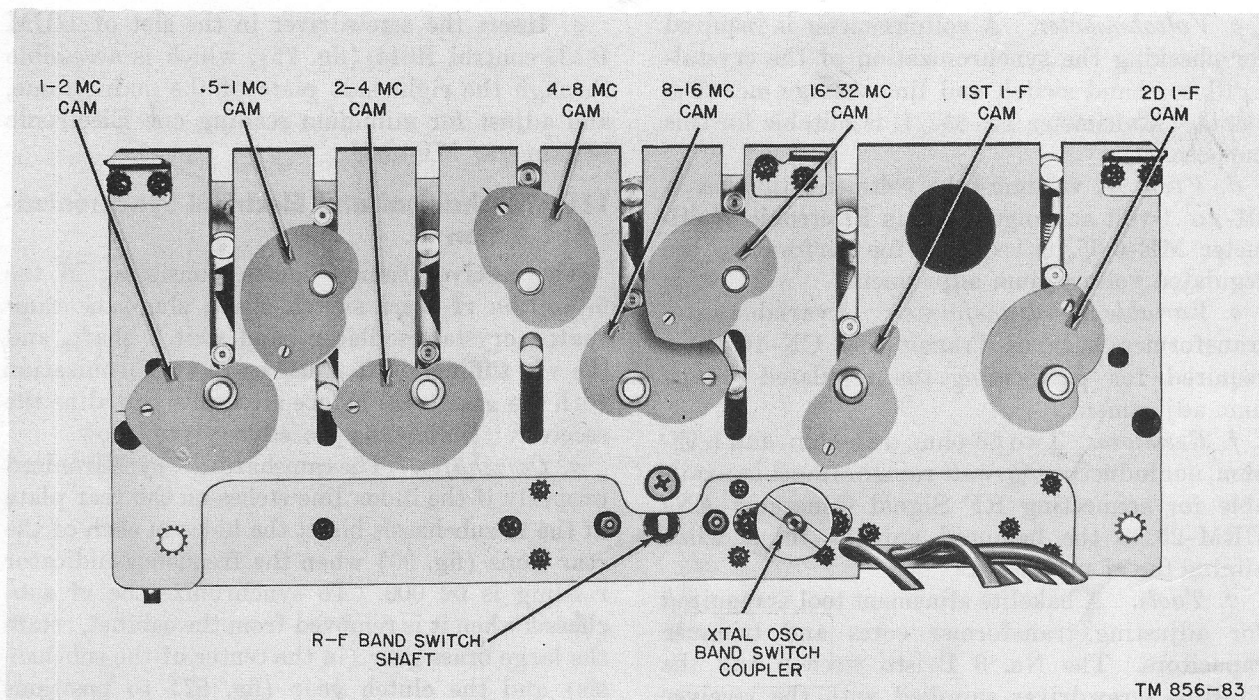

Figure 90. Rf subchassis, rear view.

and turn the SYNC XTAL OSC control (fig. 22) until the two readings correspond. Tighten the clamp on the Oldham coupler. Check the synchronization of each band by noting the position of the cam rollers at the end frequencies of each band. The position of the 1-2 mc band cam shown in figure 90 represents the correct position for the low end of the band. The position of the second if. cam shown in figure 90 represents the correct position for high end of the band (the last three digits of the frequency indicator should read 999). If all the cams are out of synchronization, set the 8-16 mc cam first.

- (2) If 1- to 2-mc camshaft (fig. 90) is not positioned properly, loosen the clamp on the front of the shaft and rotate the rear cam until the index line bisects the hole in the cam. Tighten the clamp.
- (3) Position the camshaft for .5- to 1-mc slug rack (fig. 90), if necessary, in the same manner as described in (2) above.
- (4) Check the position of the 8- to 16-mc camshaft. If it is not aligned properly, loosen the clamp on the front of the 2- to 4-mc shaft to position the 8- to 16-mc

cam, since the gear for the 8- to 16-mc shaft is pinned through the shaft. After positioning the 8- to 16-mc cam, position the 2- to 4-mc cam while holding the 8- to 16-mc cam in place. Then tighten the clamp on the 2- to 4-mc shaft.

- (5) If necessary, position the 4- to 8-mc and 16- to 32-mc cams (fig. 90) in the same manner as described in (2) above.
- (6) To position the first variable if. cam (fig. 90), loosen the clamp nearest the front plate of the rf subchassis on the crystal-oscillator band switch shaft. Adjust the position of the cam; then tighten the clamp.
- (7) Position second variable if. cam (fig. 90), if necessary, in the same manner as for 1 to 2-, .5 to 1-, 4 to 8-, and 16 to 32-mc cams.
- (8) Check the reading of the frequency indicator. If a reading of 02 is not centered within the two left-hand spaces of the indicator, loosen the clamp on the bevel gear on shaft extending from the left side of the indicator (fig. 87). Set the two number wheels for reading of 02, and retighten bevel-gear clamp.

- (9) If reading of 000 does not appear in the last three spaces of frequency-indicator dial, loosen the clamp securing bevel gear on the shaft extending from the right side of the indicator. Set the three number wheels for reading of 000.

*b. Six-Position Rf Band Switch.* The procedure for checking and synchronizing the rf band switch is as follows:

- (1) Adjust the KILOCYCLE CHANGE control for a reading of 000 in the last three spaces of the frequency indicator.
- (2) Rotate the MEGACYCLE CHANGE control fully counterclockwise, beyond the first detent position.
- (3) Connect the ohmmeter, set at the XI scale, between test point E208 (grid of tube V203 (fig. 62)) and ground.
- (4) Rotate the MEGACYCLE CHANGE control clockwise through eight detent positions. The meter should read more than 50 ohms in each position.
- (5) Rotate the MEGACYCLE CHANGE control clockwise from the eighth to the ninth detent position. The ohmmeter should show a reading. If it does not, proceed as outlined in (6), (7), and (8) below. If the indication is normal, the crystal-oscillator band switch is in synchronization; in this case, proceed with synchronization of the crystal-oscillator band switch as described in *c* below.
- (6) Rotate the MEGACYCLE CHANGE control fully counterclockwise; then turn the control clockwise through the two detent positions to the third detent position.
- (7) Remove the rf subchassis (par. 107).
- (8) Loosen the clamp on the front of the six-position switch shaft, located on the bottom of the rf subchassis. Rotate the shaft until the switch contacts are centered at position 3 by inserting long-nosed pliers in the hole at the rear of the subchassis (fig. 90) and turning the shaft. Positions of the switch contacts are shown in the schematic diagram (fig. 108, part 1). Tighten the clamp after adjustment.

*c. Crystal-Oscillator Band Switch.* The crystal oscillator band switch should be checked and synchronized as follows:

- (1) The rotor of the crystal-oscillator band switch is positioned correctly when the number centered in the slot of the switch position indicator (fig. 65) agrees with the reading of the megacycle portion (first two digits) of the frequency indicator.

- (2) If the indication is incorrect, loosen the clamp on the flange of the Oldham coupler and rotate the SYNC XTAL OSC control (fig. 22) to center the proper reading in the slot.

*d. Vfo Tuning Shaft* (fig. 88). Synchronize the vfo tuning shaft as follows:

- (1) Turn on the receiver and allow sufficient time for it to warm up.
- (2) Fabricate cable No. 1 (fig. 60), excluding RF Plug UG-88/U.
- (3) Disconnect plug P723 from jack J223 on the rf subchassis and connect P723 to RF Jack UG-89/U on fabricated cable.
- (4) Insert the center conductor on the other end of cable into UNBALANCED ANTENNA WHIP input receptacle J107 of a second Radio Receiver R-390/URR known to be in good operating condition.
- (5) Turn the BFO switch on the second receiver to the ON position, and tune the receiver between 2.2 and 3.7 mc (this represents the frequency range of the vfo) until a signal is heard. Note the frequency on the second receiver.
- (6) Loosen the clamp on the side of the Oldham coupler that is closest to the front panel to enable the vfo tuning shaft to turn freely.
- (7) Tune the second receiver to 2.955 mc and turn the shaft of the vfo until a signal is heard.

**Caution:** The vfo will be permanently damaged if the shaft is turned too far in either direction.

*Note.* With a clockwise rotation of the vfo shaft (as viewed from the front panel) the vfo frequency is decreased.

- (8) Reconnect plug P723 into J223 on rf subchassis of the first receiver. Set the FUNCTION switch to CAL and the BFO switch to ON. Connect a headset into the PHONES jack.

- (9) With the first two digits of the frequency indicator at any setting, set the KILOCYCLES CHANGE control to 500.
- (10) Tighten the clamp on the side of the Oldham coupler.
- (11) The receiver should be checked against a known station such as WWV.

### 111. Alinement of 455-kc If. Stages

(fig. 91)

*a.* Turn on RF Signal Generator Set AN/URM-25 or equivalent, and connect it to test point E210 (control grid of third mixer tube, V205).

*b.* For an output meter, connect the grounded lead of a vtvm, such as Electronic Multimeter TS-505/U, to the receiver chassis, and connect the other lead to the DIODE LOAD terminal 14, of rear terminal strip (fig. 22). Set the function switch of the voltmeter for measuring negative dc voltage.

*c.* Set the BANDWIDTH switch to the .1-KC position, RF GAIN control to 10, BFO switch to OFF, and FUNCTION switch to MGC. Allow the receiver to warm up for several minutes.

*d.* Tune the signal generator to 455 kc (unmodulated); then adjust its frequency control for peak reading on the vtvm. To obtain peak reading, it may be necessary to set the attenuation of the signal generator for high amplitude output signal (3 volts). If a reading on the vtvm is obtained, proceed with *e* below. If no reading is obtained, perform the procedure outlined in (1) and, if necessary, (2) below to secure approximate alinement before proceeding with *e* below.

- (1) With the signal generator tuned to 455 kc and the attenuator set for full output, turn the receiver BANDWIDTH switch to the 16-KC position. If the output reading is not yet obtained, proceed with (2). If it is obtained, adjust the cores of transformers T506 through T501 and T207, in that order, for peak reading on the vtvm. Then, set the BANDWIDTH switch at the next lower position, and repeat the adjustment of the transformer cores for peak output. Repeat this procedure for each setting of the BANDWIDTH switch until peak output is obtained at .1-KC position of the switch; then proceed with *e* below.

*Note.* The frequency will decrease as the slugs are screwed further into the coils, and will increase as the slugs are withdrawn.

- (2) Perform the procedure outlined in (a) through (e) below only when the transformer cores have been displaced greatly from their normal positions within the coils. Set the BANDWIDTH switch to the 2-KC position, and proceed as follows:

- (a) Tune the signal generator to 455 kc, and set the attenuator for maximum output. Remove the sixth if. amplifier tube, V506 (fig. 25), and wrap a thin wire lead around pin 1 (grid). Replace the tube, and connect the other end of the lead to the signal generator output.
- (b) Adjust the cores of transformer T506 for peak reading on the vtvm.
- (c) Apply the signal generator output to the fifth if. amplifier, V505, in the same manner as described in (a) above for V506, and adjust the cores of transformer T505 for maximum indication on the vtvm.
- (d) Repeat the above procedure for each remaining set of if. tubes and transformers in following order: V504 and T504, V503 and T503, V502 and T502, V501 and T501, and V205 and T207.
- (e) Set the BANDWIDTH switch to the .1-KC position, and proceed with the procedure outlined in *e* below.

*e.* With the signal generator output connected to the test point, set the generator frequency at 455 kc. While adjusting the attenuator of the signal generator to maintain an output of approximately 6 volts (as read on the vtvm), carefully tune the generator to the exact frequency required to obtain peak output reading on the vtvm. Do not disturb this frequency setting while carrying out the procedures outlined in *f*, *g*, and *h* below. Check the setting repeatedly during these steps to make sure it has not been changed.

*f.* Set the BANDWIDTH switch to the 2-KC position.

*g.* Adjust the cores of transformers T506, T505, T504, T503, T502, and T207, in that order, for peak output reading, while continuously adjusting the attenuator of the signal generator to maintain a reading of approximately 6 volts on the

vtvm. Repeat these adjustments until no further increase in output is noticeable.

*h.* Change the setting of the BANDWIDTH switch to the 8-KC position, and adjust the cores of transformer T501 for maximum output. Repeat the adjustment of cores until no further increase in output can be produced.

*i.* Return the BANDWIDTH switch to the .1-KC position.

*j.* Set the attenuator of the signal generator for a reading of approximately 6 volts on the vtvm, and note the attenuator setting. Tune the generator in one direction, away from the frequency required for peak reading, increasing the output of the generator to restore the vtvm reading to its original value. Continue tuning the generator in this direction until the voltage output required to obtain the original reading on the vtvm is 1,000 times the voltage required at peak frequency.

*k.* Adjust the phasing capacitor in the crystal filter, Z501, for minimum vtvm reading, and note the position of the capacitor slot.

*l.* Tune the signal generator to the opposite side of the frequency required for peak output, and set the attenuator for increased output, as directed in *j* above.

*m.* Adjust the phasing capacitor for minimum reading, and note the position; then set the capacitor approximately halfway between the two noted settings. To avoid possible incorrect readings, caused by tuning through the positions of minimum or maximum capacitance, the two settings for minimum output must be less than 45° apart.

*n.* With the BANDWIDTH switch in the .1-KC position, tune the signal generator to obtain peak output. Set the BANDWIDTH switch to the .1-KC position. Adjust the core of the tuning coil in the crystal filter (Z501) until the frequency reading required for obtaining peak output, with the BANDWIDTH switch in .1-KC position, corresponds exactly with the frequency reading required for peak output with the BANDWIDTH switch in the .1-KC position. Retune the signal generator, and alternately change positions of the BANDWIDTH switch as required to complete this adjustment.

*o.* Set the BANDWIDTH switch to the .1-KC position, and tune the signal generator for maximum output as described in *e* above. Do not disturb this frequency setting during the adjust-

ment of the agc tuning circuit in the following steps.

*p.* Disconnect the vtvm lead from terminal 14 of the rear terminal strip, and connect it to terminal 4 of the rear terminal strip (fig. 22).

*q.* Set the FUNCTION switch to AGC, and the BANDWIDTH switch to the 2-KC position.

*r.* Adjust the cord of Z503 for a maximum voltage reading on the vtvm, while adjusting the attenuator of the signal generator to maintain a peak reading of approximately 2 volts. When the adjustment is completed, disconnect the meter.

*Note.* If a signal generator is not available, the procedures given in *e* through *r* above may be followed by using the output of the calibration oscillator and the CARRIER LEVEL meter and by utilizing the RF GAIN control as an attenuator. The frequency of the calibration oscillator must be checked (par. 127), before using it for alignment.

## 112. Alinement of Second Crystal Oscillator (fig. 91)

*a.* Connect the vtvm set for reading negative dc volts, between test point E209 (fig. 62) (grid of second mixer V204) and ground.

*b.* Turn the OVENS switch to ON and the FUNCTION switch to STAND BY. Allow the receiver to warm up.

*c.* Set the MEGACYCLE CHANGE control so that the frequency indicator reads 31.

*d.* Screw the slug of T402 (fig. 65) out until only one peak reading on the vtvm can be obtained, while operating trimmer 31 (fig. 91) throughout its full range.

*e.* Set the trimmer slightly off the position for peak reading, and adjust the slug for peak indication on the vtvm.

*f.* Adjust the second crystal-oscillator trimmers (large group of trimmers on rear panel (fig. 92) using the table below. Set the MEGACYCLE CHANGE control for a megacycle reading on the frequency indicator shown in first column, and adjust the trimmer designated in second column for the meter indication shown in the last column. Where a trimmer is used in the crystal oscillator circuit at more than one frequency setting of the MEGACYCLE CHANGE control, it is listed only for the first setting and is adjusted for maximum only at this setting. For subsequent frequency settings of the MEGACYCLE CHANGE control involving a previously ad-



justed trimmer, check only for an indication on the vtvm. If no indication is obtained, the crystal-oscillator band switch should be checked.

Dial reading	Adjust trimmer	Meter indication
31	31	Maximum.
30	30	Maximum.
29	29	Maximum.
28	28	Maximum.
27	27	Maximum.
26	26	Maximum.
25	25	Maximum.
24	24	Maximum.
23	23	Maximum.
22	22	Maximum.
21	21	Maximum.
20	20	Maximum.
19	19	Maximum.
18	18	Maximum.
17	7, 17	Maximum.
16	16	Maximum.
15	3, 6, 15	Maximum.
14	14	Maximum.
13	5, 13	Maximum.
12	2, 12	Maximum.
11	4, 11	Maximum.
10	10	Maximum.
09	0, 1, 9	Maximum.
08	8	Maximum.
07	-----	Check for indication.
06	-----	Check for indication.
05	-----	Check for indication.
04	-----	Check for indication.
03	-----	Check for indication.
02	-----	Check for indication.
01	-----	Check for indication.
00	-----	Check for indication.

### 113. Alinement of First Crystal Oscillator (fig. 91)

*a.* Connect the vtvm and set for reading negative dc volts, between test point E208 (fig. 62) (grid of first mixer V203) and ground.

*b.* Turn OVENS switch to ON and FUNCTION switch to STAND BY. Allow the receiver to warm up.

*c.* Set the MEGACYCLE CHANGE control so that the megacycle reading on the frequency indicator is 03.

*d.* Adjust the slug of T401 (fig. 65) for peak indication on the vtvm.

*e.* Adjust first crystal-oscillator trimmers (group of five trimmers on the rear panel (fig. 92)) using chart below in a manner described in paragraph 112.

Dial reading	Adjust trimmer	Meter indication
07	2, 7	Maximum.
06	0, 6	Maximum.
05	1, 5	Maximum.
04	4	Maximum.
03	3	Maximum.
02	-----	Check for indication.
01		
00		

### 114. Alinement of Second Variable If. Stage (fig. 91)

*a.* Set the vtvm to measure the negative dc voltages of approximately 5 volts. Connect the ground lead to the receiver chassis, and the input lead to DIODE LOAD terminal 14 of rear terminal strip (fig. 22).

*b.* Connect the output lead of the signal generator to test point E209 (fig. 62) (control grid of second mixer V204). Connect the ground lead of the signal generator to the receiver chassis.

*c.* Set the FUNCTION switch to AGC position, and the RF GAIN control to 10.

*d.* With the MEGACYCLE CHANGE and KILOCYCLE CHANGE controls, set the frequency-indicator reading to 01 900.

*e.* Connect the headset to the PHONES jack. Turn on the signal generator modulation (30 percent at 400 cycles), and tune the generator to approximately 2100 kc to obtain an audible receiver output. While observing the output meter, tune the signal generator to the exact frequency which produces peak reading on the output meter. Change the attenuator setting of the signal generator continuously to maintain a reading of less than 5 volts on the vtvm.

*f.* Adjust the slugs of tuned circuits Z222, Z223, and Z224 for peak reading on the output meter. The three slugs are mounted on the second variable if. slug rack.

*g.* With the KILOCYCLE CHANGE control, tune the receiver to 1100 kc.

*h.* Tune the signal generator to 2900 kc, and then set it to the exact frequency which produces peak reading on the output meter.

*i.* Adjust the three trimmers mounted within the shield cans of tuned circuits Z222, Z223, and Z224 for peak output.

*j.* Repeat the procedure described in *e* through *i* until no increase in output can be obtained. While

making all adjustments, set the attenuator of the signal generator so that the reading on the vtvm is less than 5 volts.

*k.* If no test equipment is available, the second variable if. stage can be aligned, using the CARRIER LEVEL meter and the signal from the internal calibration oscillator. Disconnect coaxial connectors P209 from J109, P210 from J110, and P211 from J111, on the antenna box (fig. 86); set the FUNCTION switch at CAL and the RF GAIN control at 10; and then proceed with the alinement, using the receiver frequencies indicated in *e* and *g* above. Utilize the RF GAIN control as an attenuator to maintain the meter reading at approximately midscale while adjusting the tuned circuits.

### 115. Alinement of First Variable If. Stage (fig. 92)

*a.* Connect the signal generator lead to test point E208 (fig. 62) (control grid of first mixer tube V203). The vtvm should be connected as described in paragraph 114*a*.

*b.* With the MEGACYCLE CHANGE and KILOCYCLE CHANGE controls, set the frequency-indicator reading to 01 500.

*c.* Tune the signal generator to 9.5 mc. Reduce the output of the signal generator as required to maintain vtvm reading of less than 5 volts.

*d.* Adjust slugs of tuned circuits Z219, Z220, and Z221 for peak output reading. Slugs are mounted on the first variable if. slug rack.

*e.* Adjust the MEGACYCLE CHANGE control for a reading of 07 500 on the frequency indicator.

*f.* Tune the signal generator to 17.5 mc. Change the attenuator setting of the signal generator continuously to maintain a reading of less than 5 volts on the vtvm.

*g.* Adjust the three trimmers mounted within the shield cans of tuned circuits Z219, Z220, and Z221 for peak output.

*h.* Repeat the procedure described in *c* through *g* above until no increase in output can be obtained.

*i.* The first variable if. stage can be alined, in the absence of test equipment, in the same manner described in paragraph 114*k*. Use the receiver frequencies indicated in *b* and *e* above.

### 116. Alinement of Rf Stages

*a.* Set the FUNCTION switch to AGC, and the RF GAIN control to 10.

*b.* Connect one lead of the vtvm to DIODE LOAD terminal 14 on the rear terminal strip (fig. 22) and the other lead to the receiver chassis. The meter should be set to measure negative dc voltages of approximately 5 volts, with respect to chassis.

*c.* If preliminary adjustments (*d* below) are unnecessary, connect the signal generator to the balanced antenna input terminals by connecting either antenna input terminal of BALANCED ANTENNA 125 OHM connector J108 to the receiver ground and to the ground lead of the signal generator. Connect the other antenna input terminal, through the 95-ohm noninductive series resistor, to the output lead of the signal generator. Connect a 75-ohm noninductive resistor from the output lead of the signal generator to ground. Proceed with the procedure outlined in *e* below.

*d.* If preliminary adjustments are necessary because of extreme misalinement, connect the signal generator through .01- $\mu$ f capacitor to points listed in the last column of the chart below instead of connecting it to the antenna input terminals, and proceed with alinement as directed in *e* through *j* below and in the chart. After completing the preliminary procedure, connect the signal generator to the antenna input terminals as described in *c* above; then repeat the alinement, making all adjustments in the order listed in the chart.

*e.* With MEGACYCLE CHANGE control, set up the digits listed in the second column of chart in the first two spaces of the frequency indicator dial. With the KILOCYCLE CHANGE control, set up the digits listed in the third column in the last three spaces of the frequency indicator.

*f.* After setting the receiver frequency indicator reading for a group of adjustments, tune the signal generator to the frequency listed in the fourth column. To obtain the exact required frequency, tune the signal generator for peak reading on the vtvm; do not depend on the calibration of the signal generator.

*g.* During the alinement procedure, change the setting of the signal-generator attenuator as required to maintain an output reading of less than 5 volts.

*h.* When alining rf transformers, adjust the slugs for a set of transformers while the receiver is tuned to a lower frequency indicated in the

chart for that set of transformers; adjust the trimmer capacitors while the receiver is tuned to a higher frequency. Adjust the slugs of the set of transformers listed in the fifth column for peak output; then, after changing the frequency settings of the receiver and signal generator, adjust the trimmer capacitors of the set of transformers listed in the sixth column for peak output. Trimmer capacitors are accessible through holes in the top of shield cans, and should be adjusted with an insulated screwdriver. For antenna trans-

formers, adjust the trimmer capacitors mounted nearest to the back of the receiver for peak output reading. Front trimmers are used to balance the antenna input circuits. *Repeat the adjustments for each set of rf coils until no further change is noticeable.*

i. Set the ANT. TRIM control to 0.

j. Proceed with the rf alinement by performing adjustments in the order listed in the chart below. Refer to figure 91 for location of slugs and trimmer capacitors.

1	2	3	4	5	6	7
Set of rf coils	Megacycle reading	Kilocycle reading	Signal generator frequency (tune for peak output) in kc	Adjust slugs for peak output	Adjust trimmer capacitors for peak output	Signal generator connection (preliminary alinement only)
5-1 mc	00	600	600	Z213 Z207 Z201 T201	----- ----- ----- -----	E207. E207. E206. BALANCED antenna. J108.
	00	900	900	-----	Z213 Z207 Z201 T201 (rear trimmer)	E207. E207. E206. J108.
1-2 mc	01	100	1, 100	Z214 Z208 Z202 T202	----- ----- ----- -----	E207. E207. E206. J108.
	01	900	1, 900	-----	Z214 Z208 Z202 T202 (rear trimmer)	E207. E207. E206. J108.
2-4 mc	02	200	2, 200	Z215 Z209 Z203 T203	----- ----- ----- -----	E207. E207. E206. J108.
	03	800	3, 800	-----	Z215 Z209 Z203 T203 (rear trimmer)	E207. E207. E206. J108.
4-8 mc	04	400	4, 400	Z216 Z210 Z204 T204	----- ----- ----- -----	E207. E207. E206. J108.
	07	600	7, 600	-----	Z216 Z210 Z204 T204 (rear trimmer)	E207. E207. E206. J108.
8-16 mc	08	800	8, 800	Z217 Z211 Z205 T205	----- ----- ----- -----	E207. E207. E206. J108.

1	2	3	4	5	6	7
Set of rf coils	Megacycle reading	Kilocycle reading	Signal generator frequency (tune for peak output) in kc	Adjust slugs for peak output	Adjust trimmer capacitors for peak output	Signal generator connection (preliminary alinement only)
8-16 mc-----	15	200	15, 200		Z217----- Z211----- Z205----- T205----- (rear trimmer)-----	E207. E207. E206. J108.
16-32 mc-----	17	600	17, 600	Z218 Z212 Z206 T206		E207. E207. E206. J108.
	30	400	30, 400		Z218----- Z212----- Z206----- T206----- (rear trimmer)-----	E207. E207. E206. J108.

k. Connect two 68-ohm resistors in series and connect the free ends to the BALANCED 125 OHM ANTENNA input terminals. Connect the output lead of RF Signal Generator Set AN/URM-25 to the junction of these resistors. Be sure that the ground lead of the signal generator is connected to the receiver chassis.

l. Set the tuning controls for the frequency-indicator reading listed in the first column of the chart in *n* below and then tune the signal generator to this frequency for peak receiver output.

m. Adjust the trimmer capacitor closest to the front panel of the transformers listed in the second column of *n* below for *minimum* output. During the alinement procedure, change the setting of the signal generator attenuator to increase the output reading to approximately 5 volts.

n. In the manner described in *k*, *l*, and *m*, above, adjust the balance trimmers in the following order:

Dial reading	Transformer (front trimmer)
00 950	T201
01 900	T202
03 600	T203
07 500	T204
13 500	T205
31 500	T206

o. The rf stages may be alined without test equipment by using the CARRIER LEVEL meter and calibration-oscillator signal as de-

scribed in paragraph 114k, and using the receiver frequencies given in the preceding charts in this paragraph.

### 117. Calibration of Bfo

The bfo should be calibrated after replacing the front panel or if. subchassis subsequent to removal. Calibrate the bfo as follows:

a. Set the BANDWIDTH switch at the .1-KC position, and turn the FUNCTION switch to CAL.

b. Connect the headset to the PHONES jack. Adjust the KILOCYCLE CHANGE control for maximum response on the CARRIER LEVEL meter at any 100-kc calibration check point.

c. Set the BFO switch at ON, and adjust the BFO PITCH control for zero beat; zero beat should occur at the position of the control marked 0. If not, loosen the knob and position the knob at 0.

### 118. Adjustment of GAIN ADJ Potentiometer R562

a. Disconnect coaxial connectors P225 and P226 from J525 and J526, located on the if. subchassis (fig. 68).

b. Connect RF Signal Generator Set AN/URM-25 or equivalent between J526 and the receiver ground (chassis). Turn on the signal generator and tune it to 455 kc, modulated 30 percent at 400 cycles. Adjust the attenuator for an output of 150 microvolts ( $\mu$ v).

c. Connect a vtvm, such as Electronic Multi-meter TS-505/U, between DIODE LOAD termi-

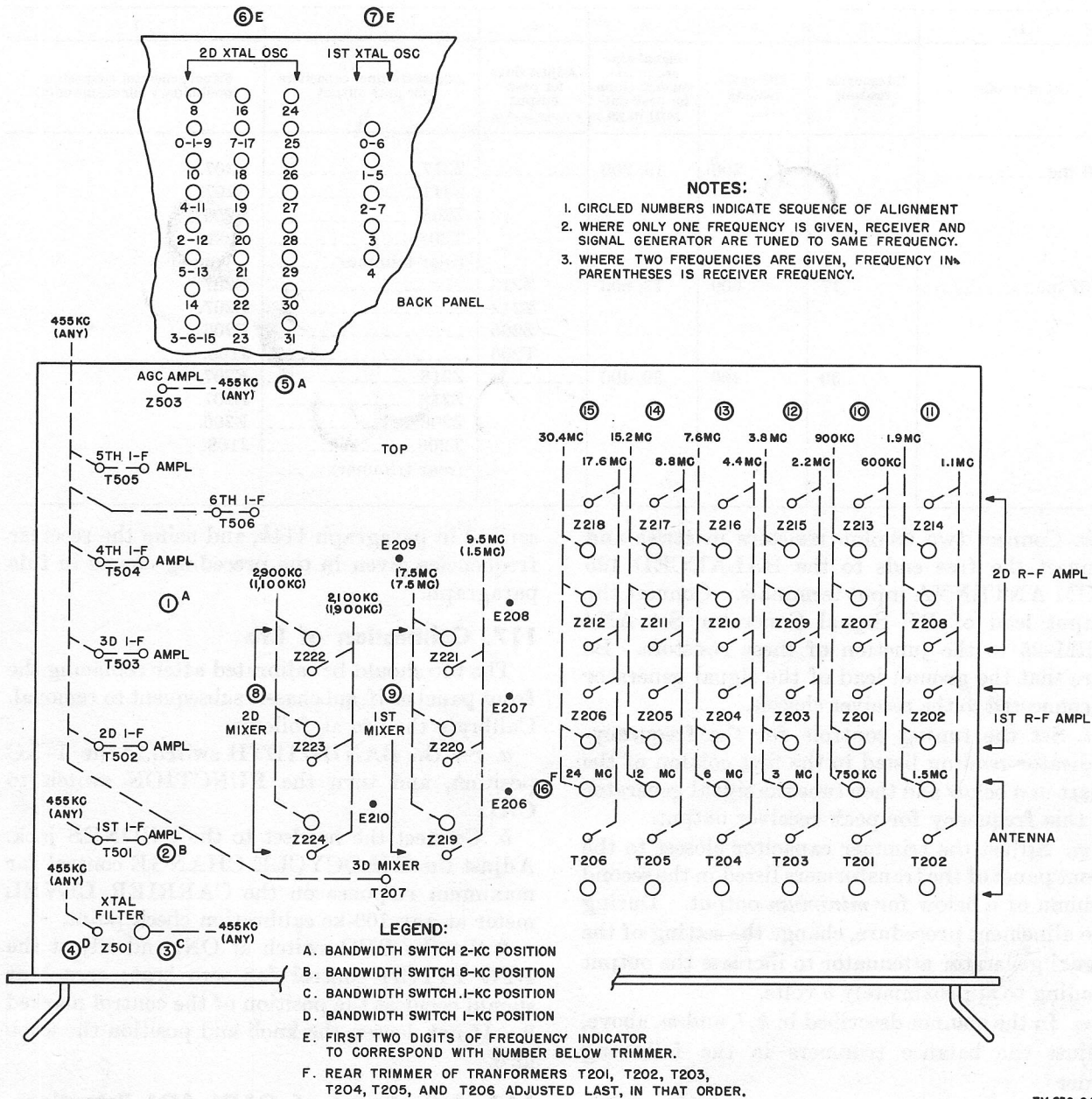

TM 856-94

Figure 91. Radio Receiver R-390/URR, alignment chart.

nal 14, on the rear terminal strip of the receiver and the receiver ground (fig. 22). Set the function switch of the meter for measuring negative dc volts.

d. Turn the receiver FUNCTION switch to MGC and RF GAIN control to position 10. Adjust GAIN ADJ potentiometer R562 (fig. 68) for a reading of -7 volts on the vtvm. Reconnect P225 and P226 after completing the adjustment.

### 119. Adjustment of CARR-METER ADJ Potentiometer R537

The CARRIER LEVEL meter is zero-adjusted using the CARR-METER ADJ potentiometer as follows: set the FUNCTION switch at AGC and rotate the RF GAIN control to its extreme counterclockwise position. Adjust R537 (fig. 68) for a reading of 0 on the CARRIER LEVEL meter.

## 120. Adjustment of Neutralizing Capacitor C525

Adjust capacitor C525 after alinement of tuning circuits has been completed, or at any time when a minimum bfo signal at the IF OUTPUT 50 OHM jack is required.

a. Connect an ac vtvm such as Electronic Multimeter ME-6/U from IF OUTPUT 50 OHM jack to ground.

b. Remove plug P225 from jack J525 (fig. 86). Use the shortest length of wire possible to ground the center terminal of the jack.

c. Turn BANDWIDTH switch to 2 KC, RF GAIN full on, BFO PITCH to 0, BFO to ON, and the FUNCTION switch to AGC.

d. Insert a screwdriver that has an insulated shank through the hole in the main frame (fig. 8) and engage trimmer capacitor C525. Turn the trimmer to obtain minimum reading on the vtvm.

**Caution:** The screwdriver for adjusting C525 must be insulated to prevent short-circuiting bare wires within the if. subchassis. A metallic screwdriver that has a length of spaghetti tubing covering the shank is satisfactory.

## Section IV. FINAL TESTING

### 121. General

This section gives the final performance tests of the equipment. Repaired equipment meeting these performance tests will furnish uniformly satisfactory operation. All of the tests in this section are to be performed while operating the receiver with a 115-volt ac input. Allow the receiver to warm up for a few minutes before making any measurements.

**Warning:** The voltages used are sufficiently high to endanger human life. Every precaution should be taken by personnel to minimize the danger of shock. The receiver chassis should be grounded during these tests.

### 122. Test Equipment Required

The test equipment required for final testing of Radio Receiver R-390/URR is listed below:

- a. Electronic Multimeter TS-505/U.
- b. Spectrum Analyzer TS-723/U.
- c. RF Signal Generator Set AN/URM-25.
- d. Audio Oscillator TS-382/U.
- e. Electron Tube Test Set TV-2/U.
- f. Multimeter TS-352/U.
- g. Electronic Multimeter ME-6/U.

### 123. Preliminary Checks

Before testing the receiver further, perform the following preliminary checks:

- a. Check to see that all controls are operative and that they do not bind.
- b. Measure B+ with Electronic Multimeter TS-505/U, or equal, with the positive lead connected to B+ 180 VDC jack J601 (fig. 75) and the negative lead connected to terminal 16, marked GND, of the rear terminal strip (fig. 22). The meter should indicate 180 volts  $\pm 5$  volts.

c. Check to see that all tubes and dial lights are lighted.

d. Check the antenna relay (par. 99k).

e. Check the bfo (par. 117).

### 124. If. Response

To check the if. response, proceed as follows:

a. Connect a vtvm (such as Electronic Multimeter TS-505/U) across DIODE LOAD terminal 14 and chassis ground on rear terminal strip (fig. 22). Set the vtvm to a negative 2-volt scale.

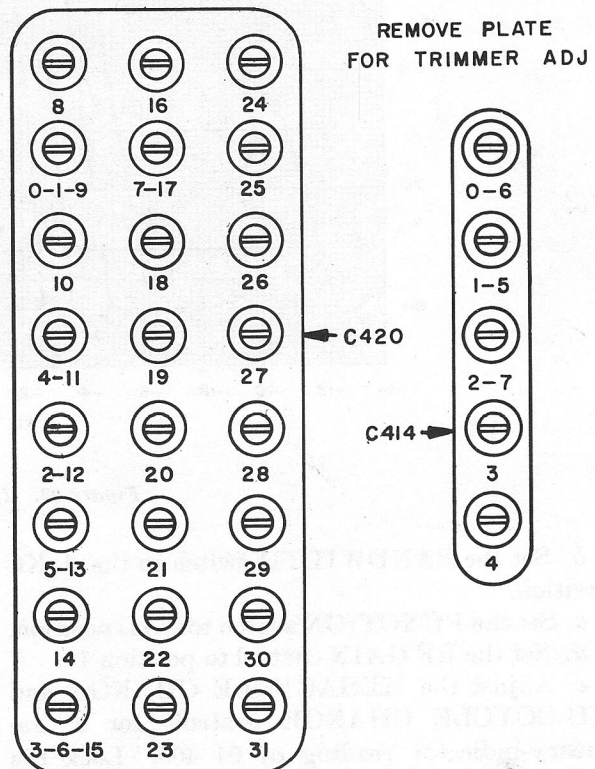

TM 856-85

Figure 92. Crystal-oscillator trimmers.

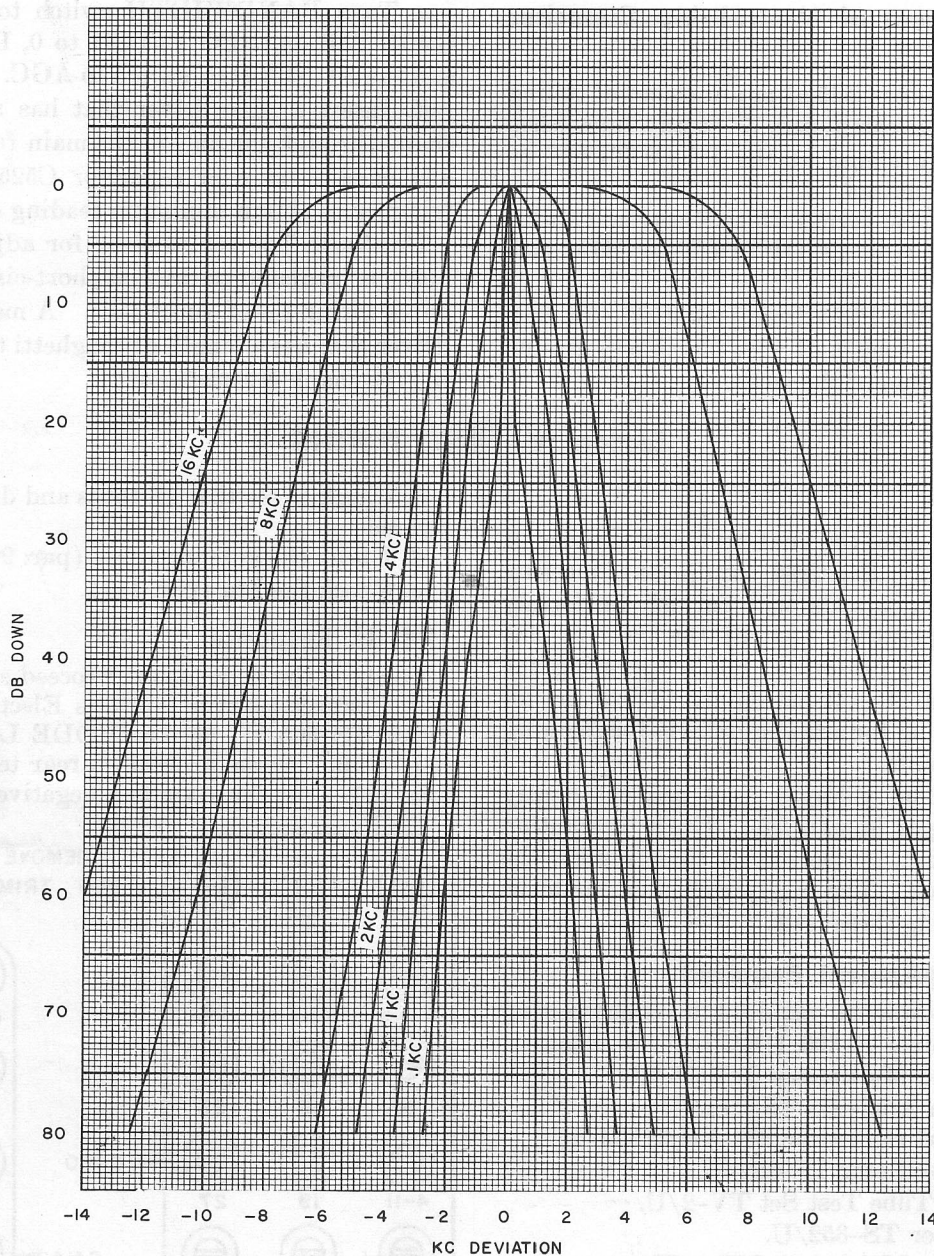

TM 856-90

Figure 93. If response chart.

- b. Set the BANDWIDTH switch to the .1-KC position.
- c. Set the FUNCTION switch to CAL position.
- d. Set the RF GAIN control to position 10.
- e. Adjust the MEGACYCLE CHANGE and KILOCYCLE CHANGE controls for a frequency-indicator reading of 04 400. Lock the ZERO ADJ.
- f. Tune Radio Receiver R-390/URR for a max-

imum indication on the vtvm. Unlock the ZERO ADJ.

- g. Set the BANDWIDTH switch to the 8-KC position.

- h. Adjust the RF GAIN control to obtain a reference voltage of 1 volt on the vtvm.

- i. Turn the KILOCYCLE CHANGE control until the vtvm indicates  $-.7$  volt. The frequency-indicator reading should be 04 396. Note the readings.

*j.* Turn the KILOCYCLE CHANGE control in the direction opposite to that described in *i* above until the vtvm indicates  $-.7$  volt. The frequency indicator reading should be 04 404. Note the readings. The voltage obtained in *i* and *k* represents 3-db points. Repeat the steps in *i* and *k* for a  $-.5$  volt indication on the vtvm. Note readings. These are the 6-db points.

*k.* Repeat *h* through *l* above with the BANDWIDTH switch set to the 16-KC position.

*l.* Compare the readings obtained for the 8 and 16-KC bandwidths with the following chart and the curves shown in figure 93.

Bandwidth	Frequency—Kilocycles	Voltage at 6-db points	Voltage at 3-db points	Reference voltage
8-KC	4 395	$-.5$		
8-KC	4 396		$-.7$	
8-KC	4 400			$-.1$
8-KC	4 404		$-.7$	
8-KC	4 405	$-.5$		
16-KC	4 392	$-.5$		
16-KC	4 393		$-.7$	
16-KC	4 400			$-.1$
16-KC	4 407		$-.7$	
16-KC	4 408	$-.5$		

## 125. Sensitivity

The test frequencies used in the sensitivity tests should be the center and the high- and low-frequency ends of each tuning range. The sensitivity of the receiver at a signal-plus-noise to noise power-output ratio is 10 to 1 for amplitude-modulation (am.) and continuous-wave (cw.) signals. To check sensitivity, proceed as follows:

*a.* Connect Cord CG-409A/U to J102 on RF Signal Generator AN/URM-25 and to Impedance Adapter MX-1074/URM-25. Connect another Cord CG-409A/U to the other end of Impedance Adapter MX-1074/URM-25 and to Adapter Connector UG-636/U. Connect Adapter Connector UG-636/U to Adapter Connector UG-971/U which is attached to BALANCED 125 OHM ANTENNA jack J108.

*b.* Connect Electronic Multimeter TS-505/U in parallel with a 600-ohm 1-watt noninductive resistor to LOCAL AUDIO terminals 6 and 7 of rear terminal strip (fig. 22).

*c.* Turn off the signal generator modulation.

*d.* Adjust the LOCAL GAIN control for a  $.8$ -volt noise indication on the vtvm.

*e.* Turn on signal generator modulation.

*f.* Adjust the output of the signal generator for a 2.45-volt ac signal-plus-noise indication on the vtvm. The output reading of the signal generator is the sensitivity for a 10- to 1-db signal-plus-noise to noise ratio for am. signals.

*Note.* The CARRIER LEVEL meter may be used instead of Electronic Multimeter TS-505/U.

*g.* The overall sensitivity of the receiver with a signal being fed into the balanced antenna should be better than  $3.3 \mu\text{v}$  for signals in the .5- to 16-mc frequency range and better than  $4.4 \mu\text{v}$  in the 16- to 32-mc frequency range.

## 126. Overall Audio Response

To check the overall audio response, proceed as follows:

*a.* Connect Cord CG-409A/U to J102 on RF Signal Generator Set AN/URM-25 and to Impedance Adapter MX-1074/URM-25. Connect another Cord CG-409A/U to the other end of Impedance Adapter MX-1074/URM-25 and to Adapter Connector UG-636. Connect Adapter Connector UG-636 to Adapter Connector UG-971 which is attached to BALANCED 125 OHM ANTENNA jack J108.

*b.* Connect Audio Oscillator TS-382/U to RF Signal Generator AN/URM-25 according to the instructions in the technical manual supplied with the oscillator.

*c.* Connect Electronic Multimeter TS-505/U in parallel with a 600-ohm 1-watt noninductive resistor to LOCAL AUDIO terminals 6 and 7, of the rear terminal strip (fig. 22).

*d.* The output of the signal generator is modulated at 30 percent. Make sure the percentage of modulation does not vary.

*e.* Set the BANDWIDTH switch to the 8-KC position.

*f.* Set the AUDIO RESPONSE switch to WIDE.

*g.* Set the frequency of Radio Receiver R-390/URR to the signal generator frequency.

*h.* Set the FUNCTION switch to the AGC position.

*i.* Set the frequency of the audio oscillator at 1,000 cps.

*j.* Set the LOCAL GAIN control to where the output meter reads 2.5 volts ac. (This will be considered a 0-db reference level.)

*k.* Vary the audio oscillator frequency between 100 and 10,000 cps.



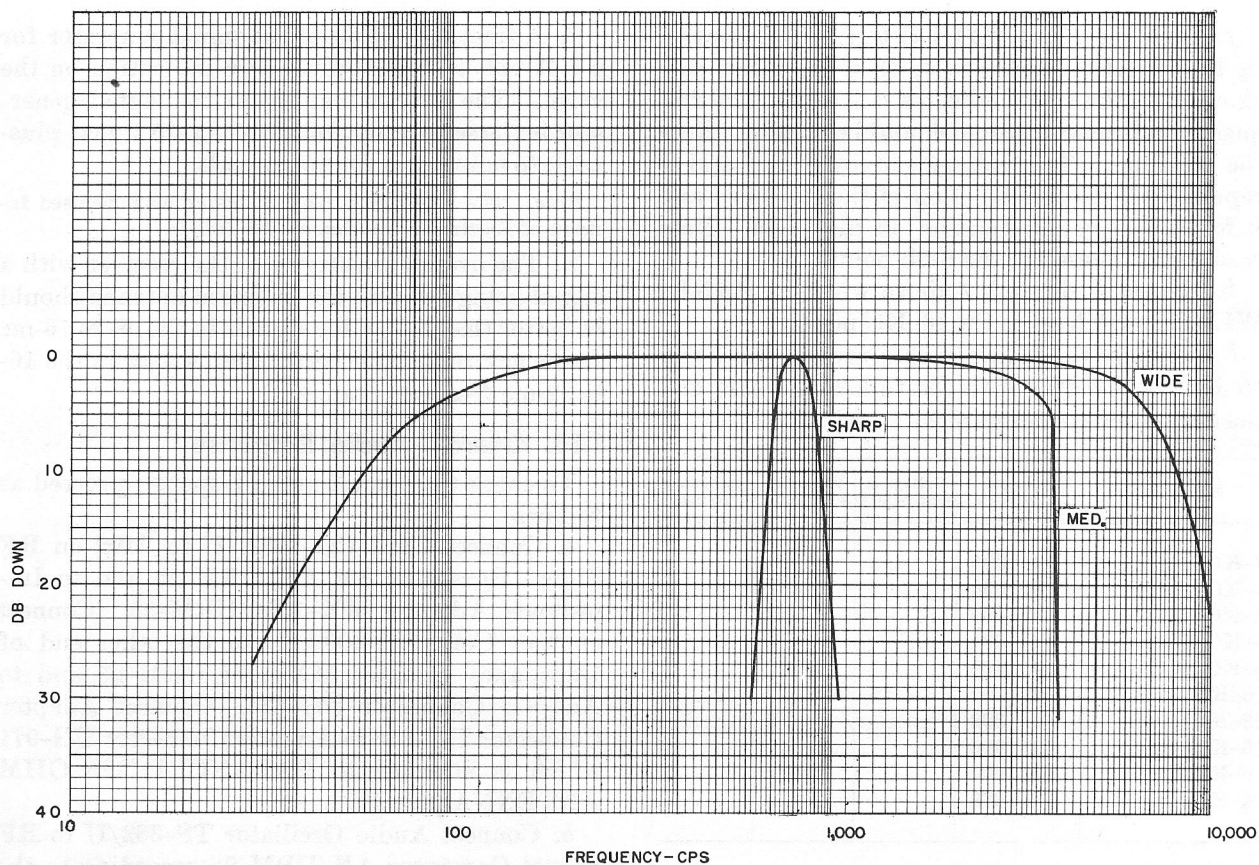

TM 856-92

Figure 94. Overall audio response chart.

l. Note the reading on the output meter and compare readings with the chart in figure 94.

$$\text{Db down} = 20 \log \frac{2.5 \text{ volts}}{\text{voltage reading on output meter}}$$

m. Repeat the steps in *i* through *l* above for the MED. and SHARP positions of the AUDIO RESPONSE switch.

### 127. Testing of Calibration Oscillator

To test the calibration oscillator, proceed as follows:

a. Set the BANDWIDTH switch to .1-KC position.

b. Set the AUDIO RESPONSE switch to MED.

c. Connect a headset into PHONES jack.

d. Turn the FUNCTION switch to CAL. In this position, a note will be heard at every multiple of 100 kc as the KILOCYCLE CHANGE control is rotated. The pitch of the note depends on the setting of the BFO PITCH control.

e. Rotate the KILOCYCLE CHANGE control through a minimum of ten 100-kc steps. If a note is not heard exactly at the 100-kc steps, adjust capacitor C912 (fig. 76). Check at least eleven 100-kc positions to make sure a note is heard only in 100-kc steps.

f. Set the FUNCTION switch to AGC, and adjust the MEGACYCLE CHANGE and KILOCYCLE CHANGE controls to obtain 10-mc reading (transmitting frequency of WWV) on frequency indicator. If WWV cannot be heard on 10-mc, try other frequencies such as 2.5-mc, 5-mc, 15-mc, or 20-mc.

g. Adjust BFO PITCH control to zero.

h. Adjust KILOCYCLE CHANGE control to zero beat to station WWV.

i. Turn FUNCTION switch to the CAL position.

j. Disconnect antenna from receiver.

k. Adjust capacitor C901 (fig. 76) for a zero beat indication.

## CHAPTER 6

# SHIPMENT AND LIMITED STORAGE AND DEMOLITION TO PREVENT ENEMY USE

### Section I. SHIPMENT AND LIMITED STORAGE

#### 128. Disassembly

The following instructions are presented as a guide for preparing Radio Receiver R-390/URR for transportation and storage.

*a.* Disconnect antenna lead-in cable, Power Cable Assembly CX-1358/U and all connections to the auxiliary equipment, if used.

*b.* Disconnect the headphones from the front panel.

*c.* Remove the receiver from the rack.

#### 129. Repacking for Shipment or Limited Storage

*a.* The exact procedure for repacking depends

on the available material and the conditions under which the equipment is to be shipped or stored. Reverse the procedure order in paragraph 15 for repacking.

*b.* Whenever practicable, place a dehydrating agent, such as silica gel, inside the receiver. Wrap the receiver and spare parts box in corrugated paper, and protect each package with a waterproof barrier. Seal the seams of the paper barrier with waterproof sealing compound or tape. Pack the protected components in a padded wooden crate, providing at least three inches of excelsior or similar material between the paper barrier and the packing case.

### Section II. DEMOLITION OF MATERIEL TO PREVENT ENEMY USE

#### 130. General

The demolition procedures outlined in paragraph 131 will be used to prevent the enemy from using or salvaging this equipment. Demolition of the equipment will be accomplished only upon order of the commander.

#### 131. Methods of Destruction

*a. Smash.* Smash the crystals, controls, tubes, coils, switches, capacitors, transformers, and headsets; use sledges, axes, handaxes, pickaxes, hammers, crowbars, or other heavy tools.

*b. Cut.* Cut cords, headsets, and wiring; use axes, handaxes, or machetes.

*c. Burn.* Burn cords, resistors, capacitors, coils, wiring, and technical manuals; use gasoline, kerosene, oil, flame throwers, or incendiary bombs.

*d. Bend.* Bend dials, cabinet, and chassis.

*e. Explosives.* If explosives are necessary, use firearms, grenades, or TNT.

*f. Disposal.* Bury or scatter the destroyed parts in slit trenches, fox holes, or other holes, or throw them into streams.

*g. Destroy.* Destroy everything.

## RESISTOR COLOR CODE MARKING (MIL-STD RESISTORS)

### AXIAL-LEAD RESISTORS (INSULATED)

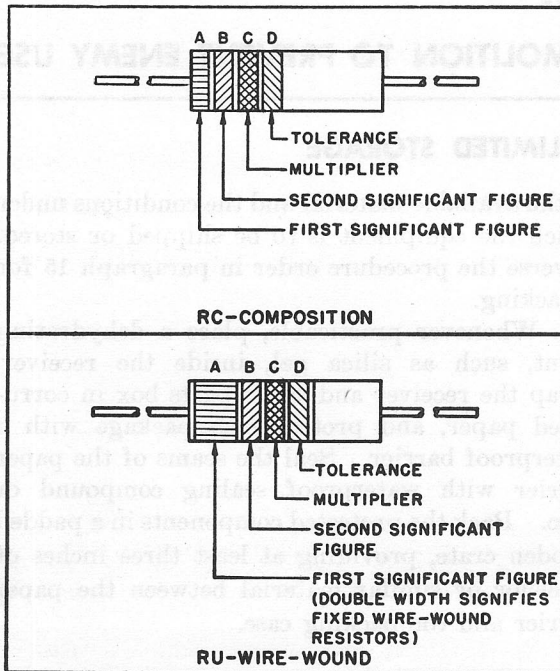

### RADIAL-LEAD RESISTORS (UNINSULATED)

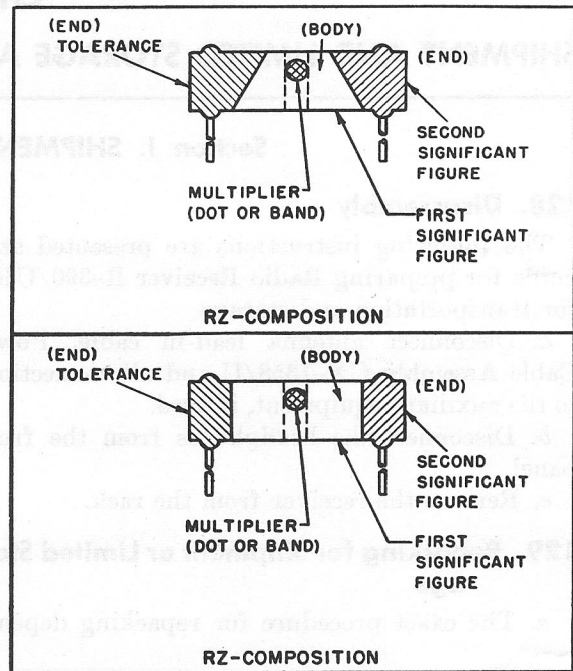

### RESISTOR COLOR CODE

BAND A OR BODY*		BAND B OR END*		BAND C OR DOT OR BAND*		BAND D OR END*	
COLOR	FIRST SIGNIFICANT FIGURE	COLOR	SECOND SIGNIFICANT FIGURE	COLOR	MULTIPLIER	COLOR	RESISTANCE TOLERANCE (PERCENT)
BLACK	0	BLACK	0	BLACK	1	BODY	$\pm 20$
BROWN	1	BROWN	1	BROWN	10	SILVER	$\pm 10$
RED	2	RED	2	RED	100	GOLD	$\pm 5$
ORANGE	3	ORANGE	3	ORANGE	1,000		
YELLOW	4	YELLOW	4	YELLOW	10,000		
GREEN	5	GREEN	5	GREEN	100,000		
BLUE	6	BLUE	6	BLUE	1,000,000		
PURPLE (VIOLET)	7	PURPLE (VIOLET)	7				
GRAY	8	GRAY	8	GOLD	0.1		
WHITE	9	WHITE	9	SILVER	0.01		

\* FOR WIRE-WOUND-TYPE RESISTORS, BAND A SHALL BE DOUBLE-WIDTH. WHEN BODY COLOR IS THE SAME AS THE DOT (OR BAND) OR END COLOR, THE COLORS ARE DIFFERENTIATED BY SHADE, GLOSS, OR OTHER MEANS.

**EXAMPLES (BAND MARKING):**

10 OHMS  $\pm 20$  PERCENT: BROWN BAND A; BLACK BAND B; BLACK BAND C; NO BAND D.  
4.7 OHMS  $\pm 5$  PERCENT: YELLOW BAND A; PURPLE BAND B; GOLD BAND C; GOLD BAND D.

**EXAMPLES (BODY MARKING):**

10 OHMS  $\pm 20$  PERCENT: BROWN BODY; BLACK END; BLACK DOT OR BAND; BODY COLOR ON TOLERANCE END.  
3,000 OHMS  $\pm 10$  PERCENT: ORANGE BODY; BLACK END; RED DOT OR BAND; SILVER END.

STD-R1

## CAPACITOR COLOR CODE MARKING (MIL-STD CAPACITORS)

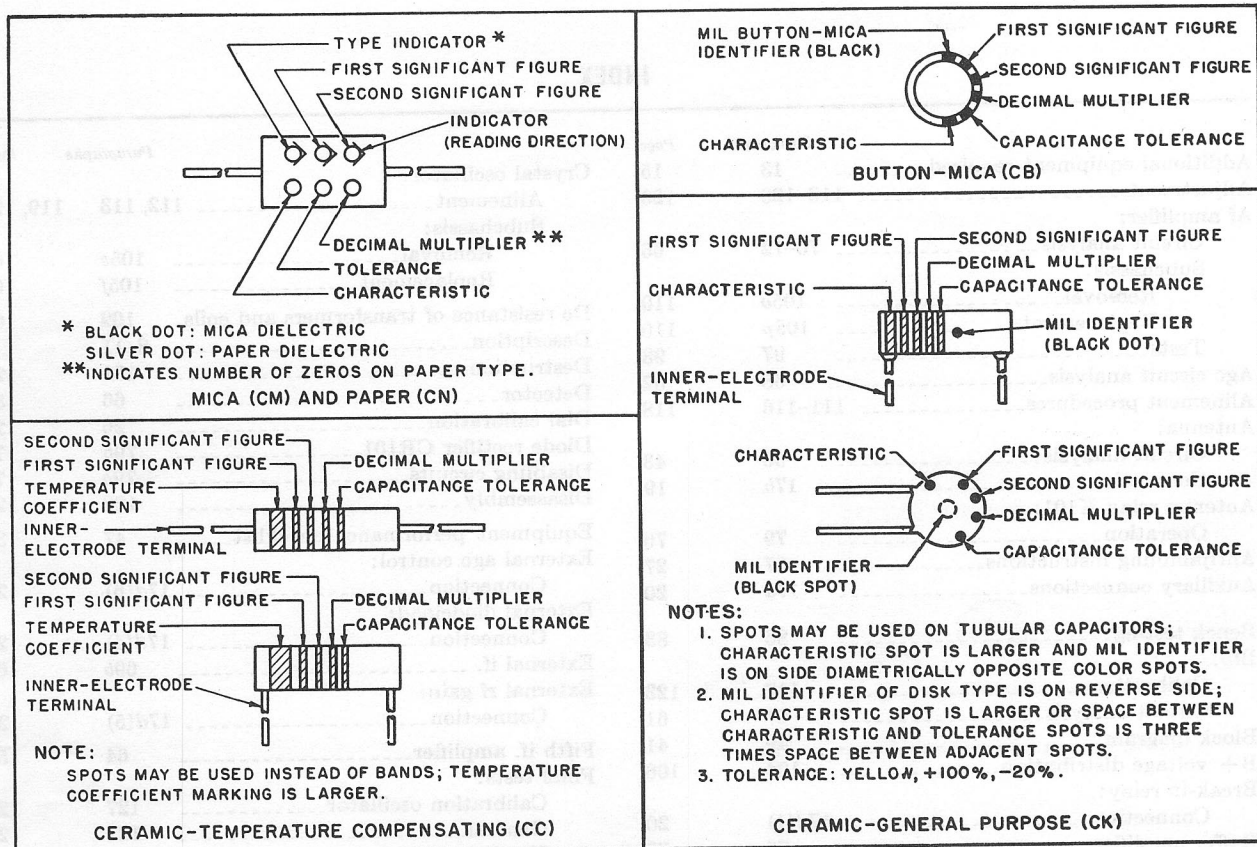

## CAPACITOR COLOR CODE

COLOR	SIG FIG.	MULTIPLIER		CHARACTERISTIC <sup>1</sup>				TOLERANCE <sup>2</sup>					TEMPERATURE COEFFICIENT (UUF/UF/°C)
		DECIMAL	NUMBER OF ZEROS	CM	CN	CB	CK	CM	CN	CB	CC		
											OVER IOUUF	IOUUF OR LESS	CC
BLACK	0	1	NONE		A			20	20	20	20	2	ZERO
BROWN	1	10	1	B	E	B	W					1	-30
RED	2	100	2	C	H		X	2		2	2		-80
ORANGE	3	1,000	3	D	J	D			30				-150
YELLOW	4	10,000	4	E	P								-220
GREEN	5		5	F	R						5	0.5	-330
BLUE	6		6		S								-470
PURPLE (VIOLET)	7		7		T	W							-750
GRAY	8		8			X						0.25	+30
WHITE	9		9								10	1	-330(±500) <sup>3</sup>
GOLD		0.1						5		5			+100
SILVER		0.01						10	10	10			

1. LETTERS ARE IN TYPE DESIGNATIONS GIVEN IN MIL-C SPECIFICATIONS.  
2. IN PERCENT, EXCEPT IN UUF FOR CC-TYPE CAPACITORS OF 10 UUF OR LESS.  
3. INTENDED FOR USE IN CIRCUITS NOT REQUIRING COMPENSATION.

Figure 96. MIL-STD capacitor color code.

## INDEX

	<i>Paragraphs</i>	<i>Page</i>		<i>Paragraphs</i>	<i>Page</i>
Additional equipment required.....	13	15	Crystal oscillator:		
Adjustments.....	118-120	123	Alinement.....	112, 113	119, 120
Af amplifier:			Subchassis:		
Circuit analysis.....	70-72	66	Removal.....	105e	108
Subchassis:			Replacement.....	105f	109
Removal.....	105o	110	Dc resistance of transformers and coils.....	102	104
Replacement.....	105p	110	Description.....	8-11	7
Tests.....	97	93	Destruction.....	131	129
Age circuit analysis.....	68	62	Detector.....	66	59
Alinement procedures.....	111-116	118	Dial calibration.....	26	26
Antenna:			Diode rectifier CR101.....	79b	78
Circuit analysis.....	50	43	Disabling circuits.....	79a	76
Connection.....	17b	19	Disassembly.....	128	129
Antenna relay K101:			Equipment performance checklist.....	47	38
Operation.....	79	76	External age control:		
Antijamming instructions.....	27	27	Connection.....	17d(6)	21
Auxiliary connections.....	17d	20	External diode load:		
Bench testing.....	86	83	Connection.....	17d(4)	21
Bfo:			External if.....	69b	65
Calibration.....	117	123	External rf gain:		
Circuit analysis.....	67	61	Connection.....	17d(5)	21
Block diagram.....	49	41	Fifth if. amplifier.....	64	57
B+ voltage distribution.....	104	106	Final tests:		
Break-in relay:			Calibration oscillator.....	127	128
Connection.....	17d(1)	20	General.....	121	125
Buffer amplifier.....	76	73	If. response.....	124	125
Cabinets and cases, description.....	9	10	Overall audio response.....	126	127
Calibration oscillator:			Preliminary checks.....	123	125
Circuit analysis.....	74	71	Sensitivity.....	125	127
Subchassis:			Test equipment.....	122	125
Removal.....	105m	110	First crystal oscillator.....	54	46
Replacement.....	105n	110	First if. amplifier.....	61	55
CARR-METER ADJ.....	119	124	First mixer.....	53	46
Cathode follower.....	69	65	Forms and records.....	2	3
Components, table.....	7	7	Fourth if. amplifier.....	63	56
Connections:			Frequency indicator calibration.....	26	26
Antenna:			Front panel:		
Balanced 125 ohm.....	17b(2)	20	Removal.....	105a	106
Unbalanced whip.....	17b(1)	19	Replacement.....	105b	107
Audio output.....	17c	20	Function switch.....	78	75
Auxiliary.....	17d	20	GAIN ADJ.....	118	123
Ground.....	17	18	If.:		
Power input.....	17a	19	Alinement.....	111	118
Space-diversity, radioteletype operation.....	4	3	Circuit analysis.....	60-65	55
Space-diversity reception.....	4	3	Stage gain chart.....	101	102
Space - diversity, single - sideband radioteletype operation.....	4	3	Subchassis:		
Control circuits.....	79	76	Removal.....	105g	109
Controls.....	20, 21	22, 24	Replacement.....	105h	109
Crystal checking.....	100	100	Tests.....	98	96
Crystal filter:			Initial inspection.....	89	85
Circuit analysis.....	59	53	Installation:		
			Antenna.....	16a	18
			Radio Receiver R-390/URR.....	16b	18

	Paragraphs	Page		Paragraphs	Page
Intermittents.....	83b(7)	83	Second if. amplifier.....	62	56
Limiter.....	66	59	Second mixer.....	55	47
Line audio channel.....	72	68	Sidetone:		
Tests.....	96	92	Signal substitution.....	94	89
Line level meter.....	72b	69	Siting requirements:		
Local audio channel.....	71	67	External.....	14a	16
Tests.....	95	91	Internal.....	14b	16
Lubrication.....	106	112	Sixth if. amplifier.....	65	58
Mechanical tuning system.....	80-82	78	Special tools.....	34	29
Multivibrator.....	75	72	Squelch circuit.....	73	69
Operation.....	22-27	25	Stage gain charts.....	101	102
Operational test.....	83b(3)	82	Starting.....	22	25
Packaging data.....	6	7	Stopping.....	28	27
Power Cable Assembly CX-1358/U.....	11	11	Subchassis testing.....	45	36
Power Supply PP-621/URR:			Synchronization of tuning shafts.....	110	115
Circuit analysis.....	77a	73	System application.....	4	3
Description.....	10	11	Technical characteristics.....	5	6
Removal.....	105i	109	Test equipment.....	85, 108	83, 114
Replacement.....	105j	109	Third if. amplifier.....	63	56
Preventive maintenance.....	35-38	29	Third mixer.....	57	50
Purpose.....	3	3	Tone-modulated radiotelegraph recep- tion.....	24	26
Radio Receiver R-390/URR:			Tools and materials.....	33	29
Block diagram.....	49	41	Troubleshooting:		
Description.....	8	7	Chart.....	92	87
Controls.....	21	24	Data.....	84	83
Operation:			Field maintenance level.....	83	82
Arctic climate.....	30	28	Checking B+ and filament cir- cuits.....	90	85
Desert climate.....	32	28	Notes.....	88	84
Principles.....	48	41	Organizational level.....	41	33
Tropical climate.....	31	28	Precautions.....	87	84
Purpose.....	3	3	Procedure.....	83	82
Starting procedure.....	22	25	Test equipment.....	85	83
Stopping procedure.....	28	27	Tube testing.....	45	36
Technical characteristics.....	5	6	Uncrating and unpacking:		
Reconditioned equipment, service.....	19	22	Domestic.....	15b	16
Refinishing.....	107	114	Overseas.....	15b	16
Regulated-voltage hum adjustment.....	109	115	Uncrating, unpacking, and checking new equipment:		
Regulation, voltage.....	77b	74	Checking.....	15c	17
Repacking.....	129	129	Installation of Radio Receiver R-390/URR.....	16b	18
Rf amplifier:			Used equipment.....	19	22
Alinement.....	116	121	Vfo:		
Circuit analysis.....	51, 52	45	Circuit analysis.....	58	51
Stage gain chart.....	101	102	Subchassis:		
Subchassis:			Removal.....	105k	109
Removal.....	105c	107	Replacement.....	105l	110
Replacements.....	105d	107	Visual inspection.....	42	34
Tests.....	99	97	Voice reception.....	23	26
Rf and variable if. conversion scheme.....	103	105	Voltage and resistance checks.....	93	88
Running spares.....	12	11	Weatherproofing.....	39	33
Rustproofing and painting.....	40	33			
Scope.....	1	3			
Second crystal oscillator.....	56	49			

[AG 413.44 (15 Oct 54)]

BY ORDER OF THE SECRETARIES OF THE ARMY AND THE AIR FORCE:

M. B. RIDGWAY,  
General, United States Army,  
Chief of Staff.

OFFICIAL:

JOHN A. KLEIN,  
Major General, United States Army,  
The Adjutant General.

OFFICIAL:

E. E. TORO,  
Colonel, United States Air Force,  
Air Adjutant General.

N. F. TWINING,  
Chief of Staff, United States Air Force.

DISTRIBUTION:

Active Army:

Tec Svc, DA (1)	Tng Div (2)
Tec Svc Bd (1)	Ft & Cp (2)
AFF (5)	Gen & Br Svc Sch (5)
AFF Bd (incl ea Test Sec) (1)	SigC Sch (25)
Army AA Comd (2)	Gen Depots (2)
OS Maj Comd (5)	SigC Sec, Gen Depots (10)
OS Base Comd (5)	SigC Depots (20)
Log Comd (5)	POE (2)
MDW (1)	OS Sup Agencies (2)
Armies (5)	SigC Fld Maint Shops (3)
Corps (2)	SigC Lab (5)

Mil Dist (1)

Units organized under following  
TOE's:

11-127, Sig Rep Co (2)  
11-128A, Sig Depot Co (2)  
11-500A (AA-AE), Sig Admin  
Teams (2)  
11-587A, Sig Base Maint (2)  
11-592A, Hq & Hq Co, Sig Base  
Depot (2)  
11-597A, Sig Base Depot Co (2)

NG: None.

USAR: None.

Unless otherwise noted, distribution applies to ConUS and overseas.

For explanation of abbreviations used, see SR 320-50-1.

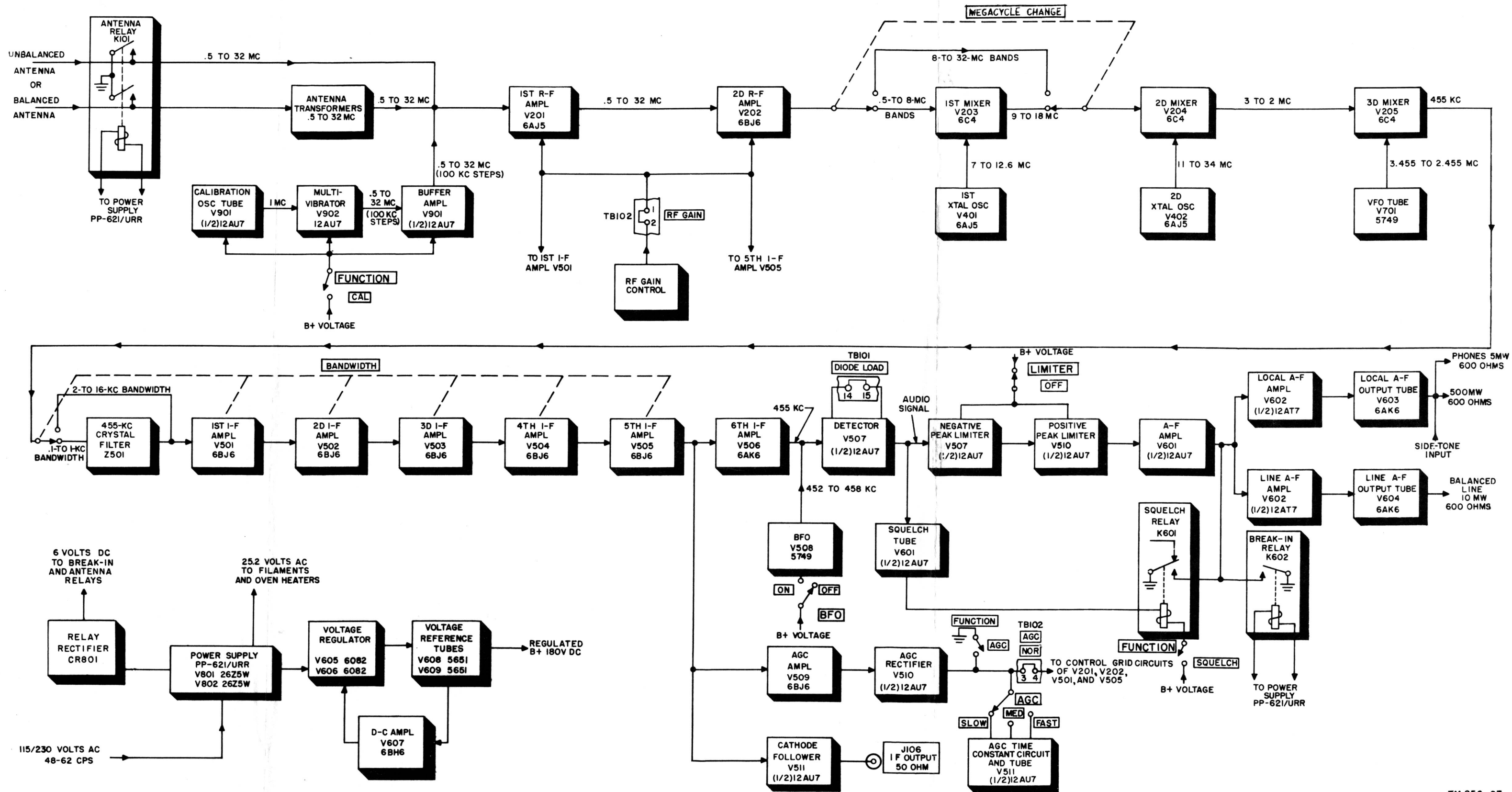

Figure 27. Radio Receiver R-390/URR, block diagram.



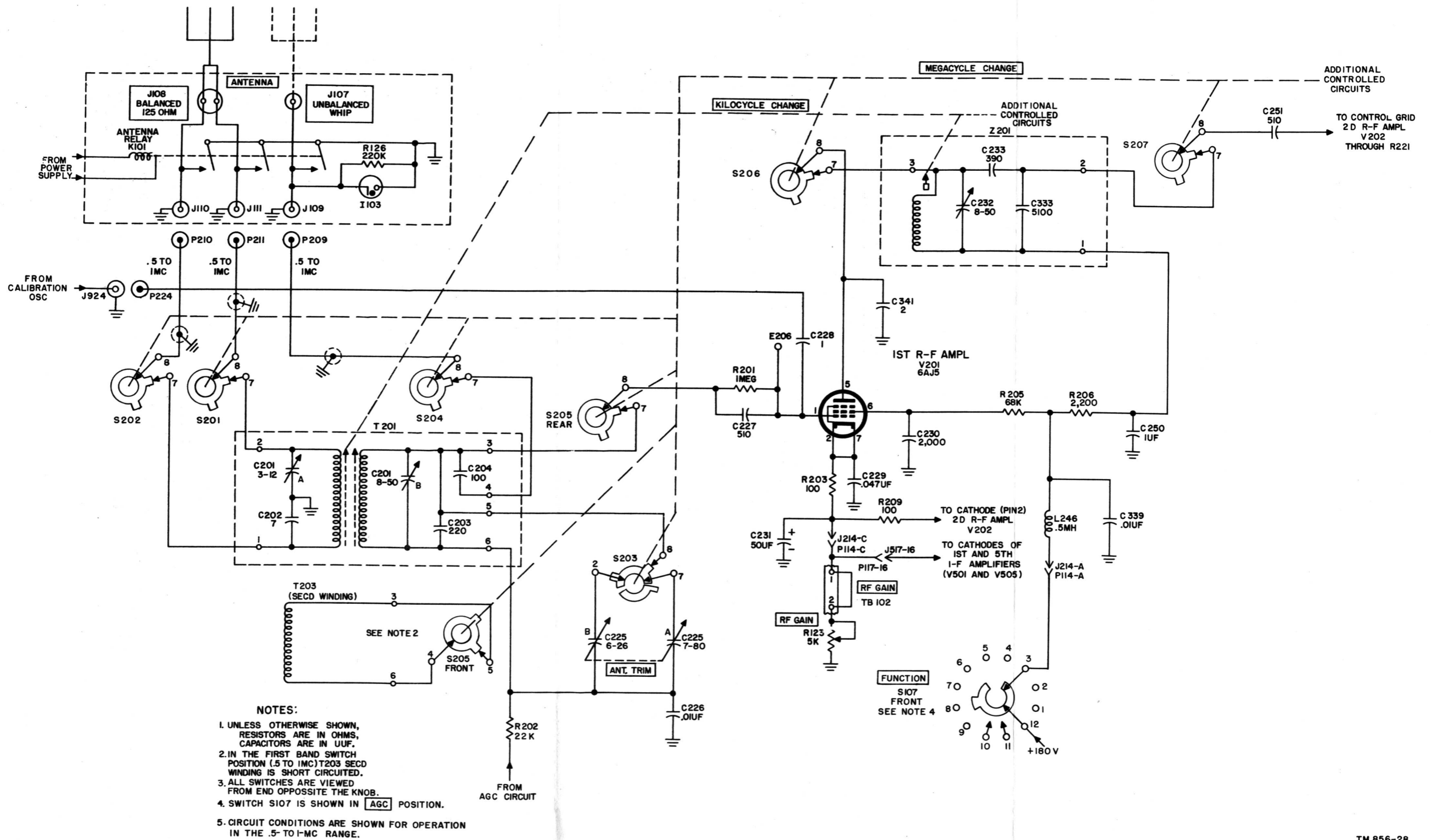

Figure 28. Antenna circuit and first rf amplifier, schematic diagram

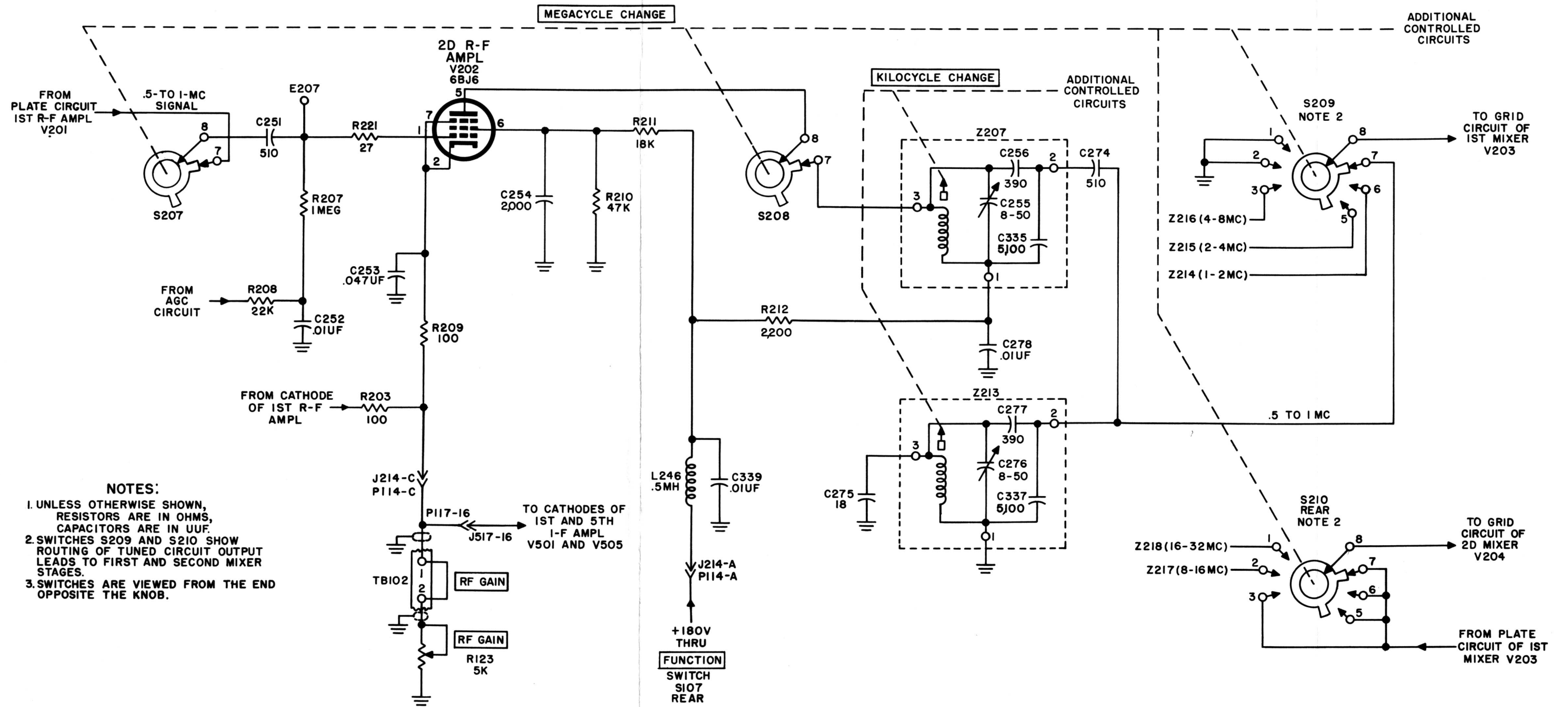
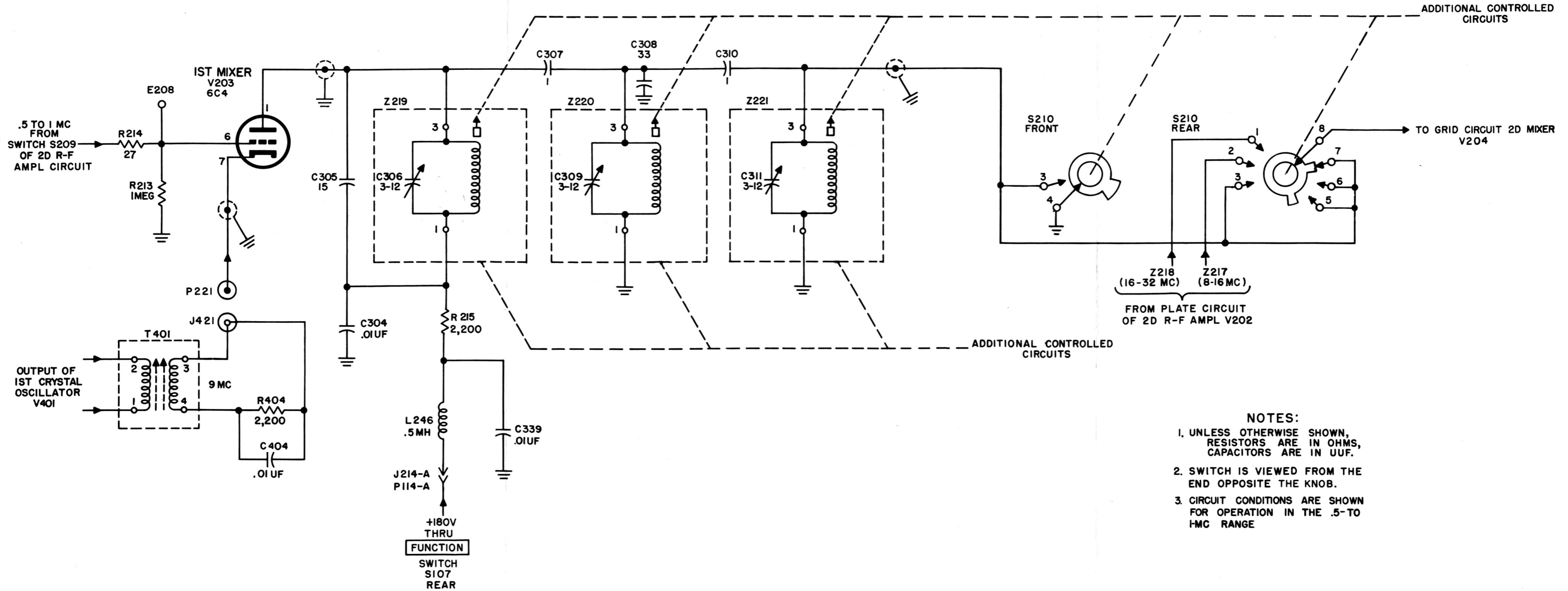

Figure 29. Second rf amplifier, schematic diagram.



- NOTES:**
1. UNLESS OTHERWISE SHOWN, RESISTORS ARE IN OHMS, CAPACITORS ARE IN UUF.
  2. SWITCH IS VIEWED FROM THE END OPPOSITE THE KNOB.
  3. CIRCUIT CONDITIONS ARE SHOWN FOR OPERATION IN THE .5-TO 1-MC RANGE

Figure 30. First mixer stage, schematic diagram.

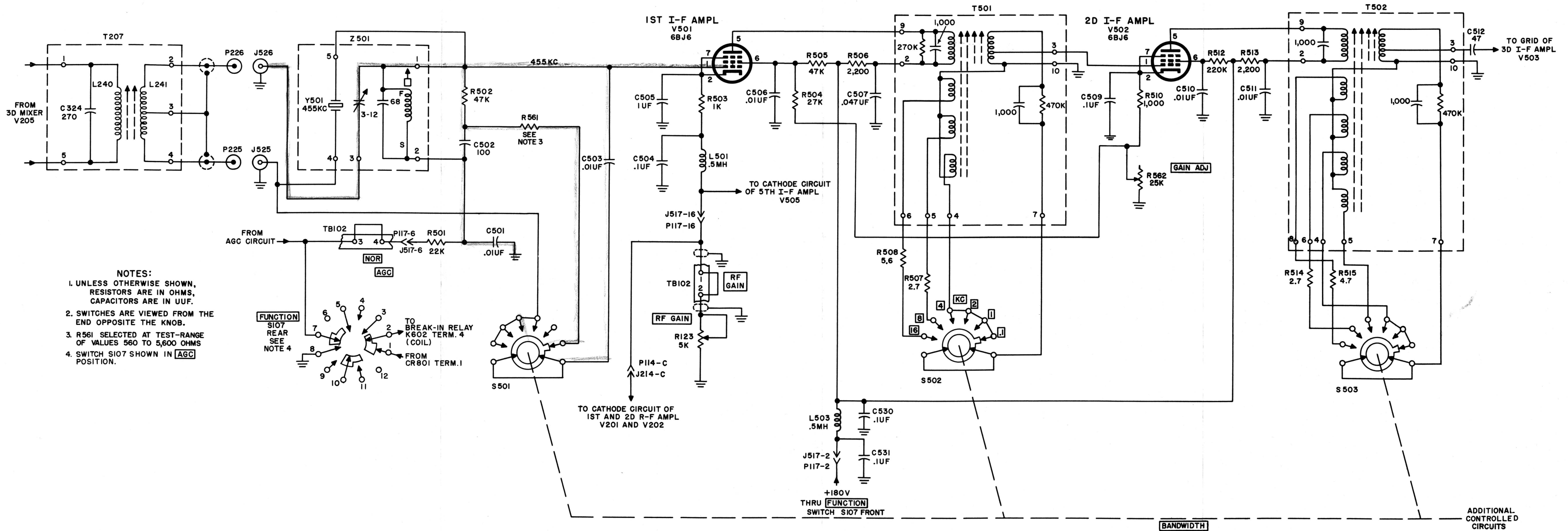

Figure 37. First and second if. amplifiers, schematic diagram.

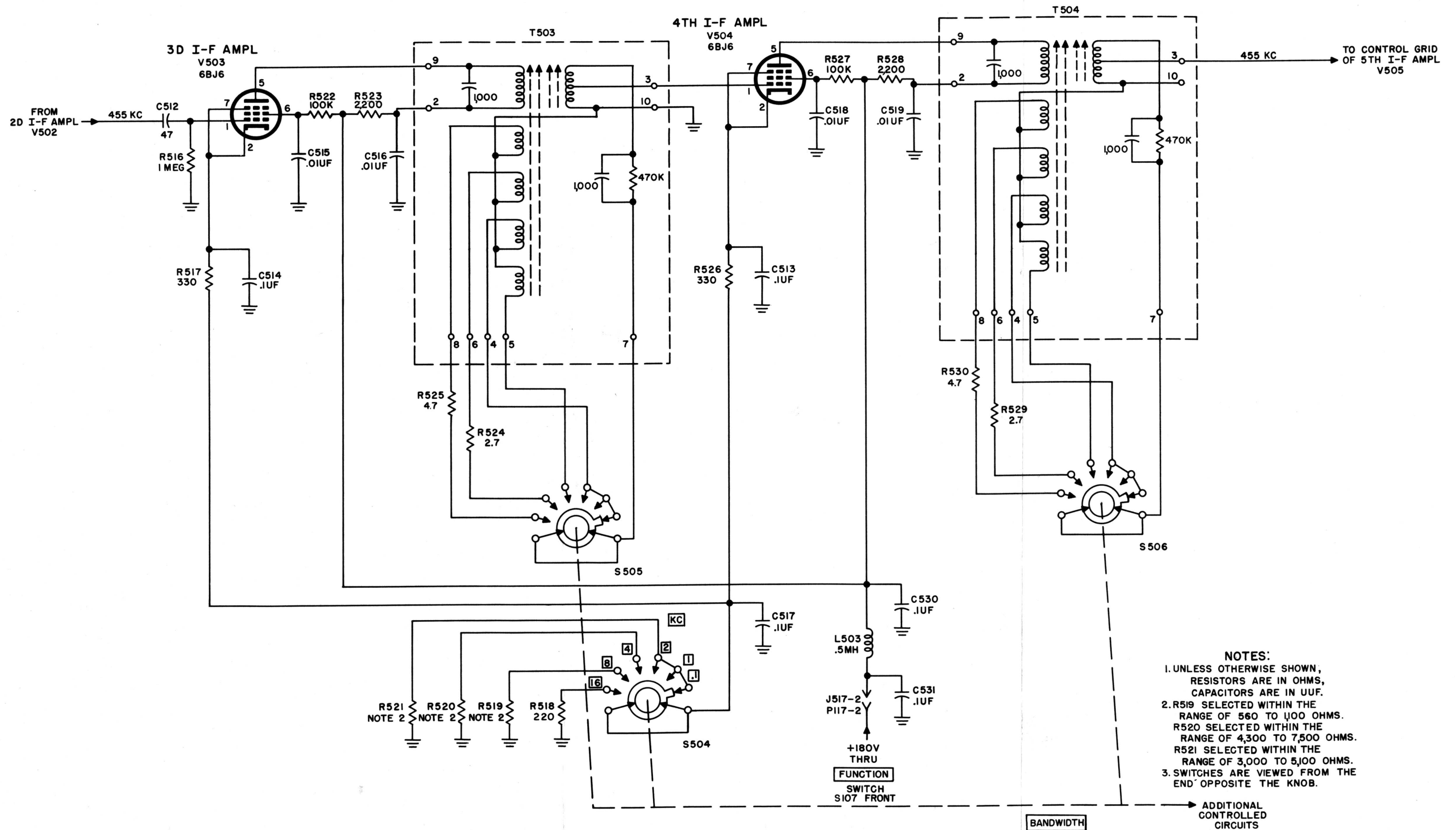
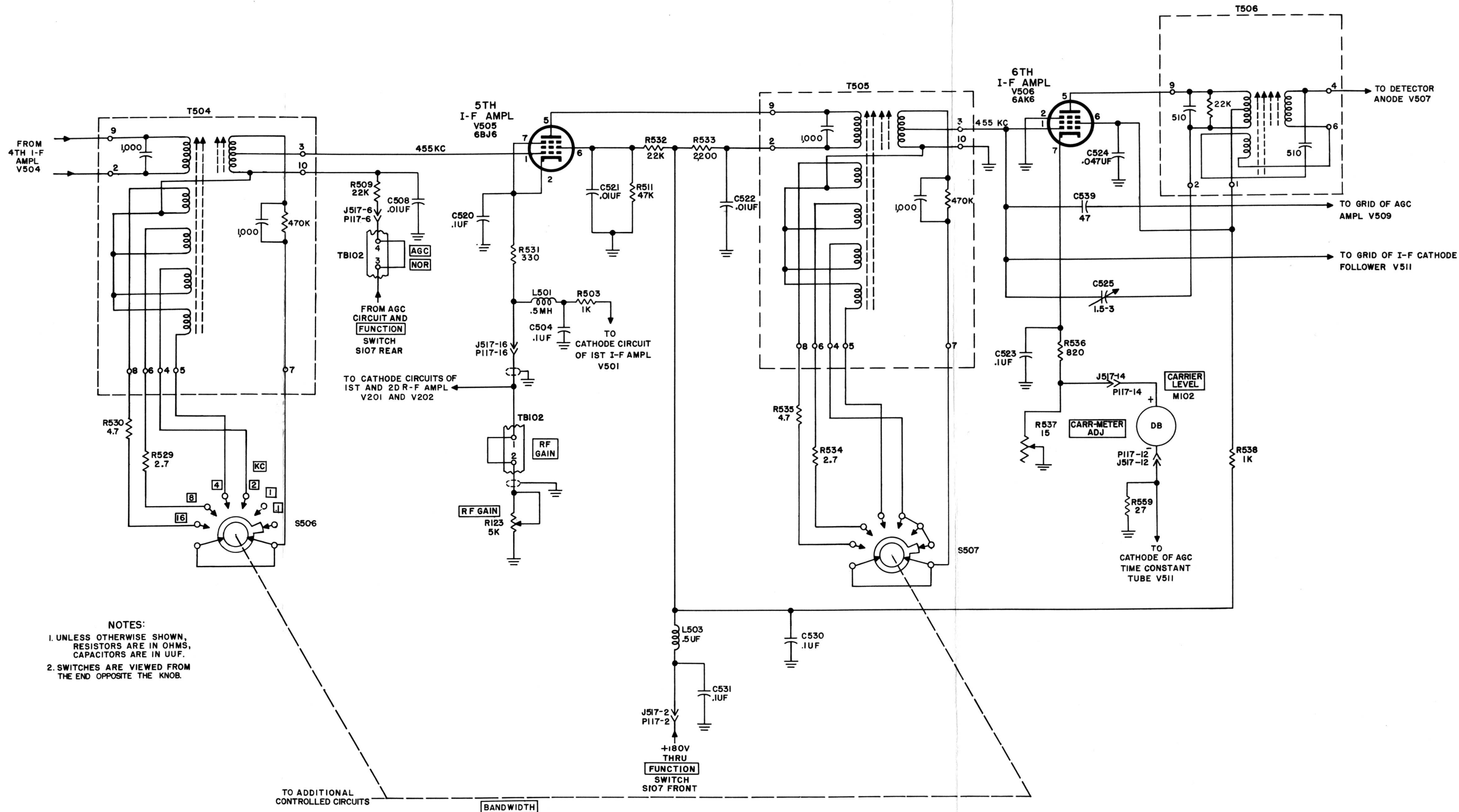

Figure 38. Third and fourth if. amplifiers, schematic diagram.



NOTES:  
 1. UNLESS OTHERWISE SHOWN, RESISTORS ARE IN OHMS, CAPACITORS ARE IN UUF.  
 2. SWITCHES ARE VIEWED FROM THE END OPPOSITE THE KNOB.

TO ADDITIONAL CONTROLLED CIRCUITS

BANDWIDTH

Figure 39. Fifth and sixth if. amplifiers, schematic diagram.

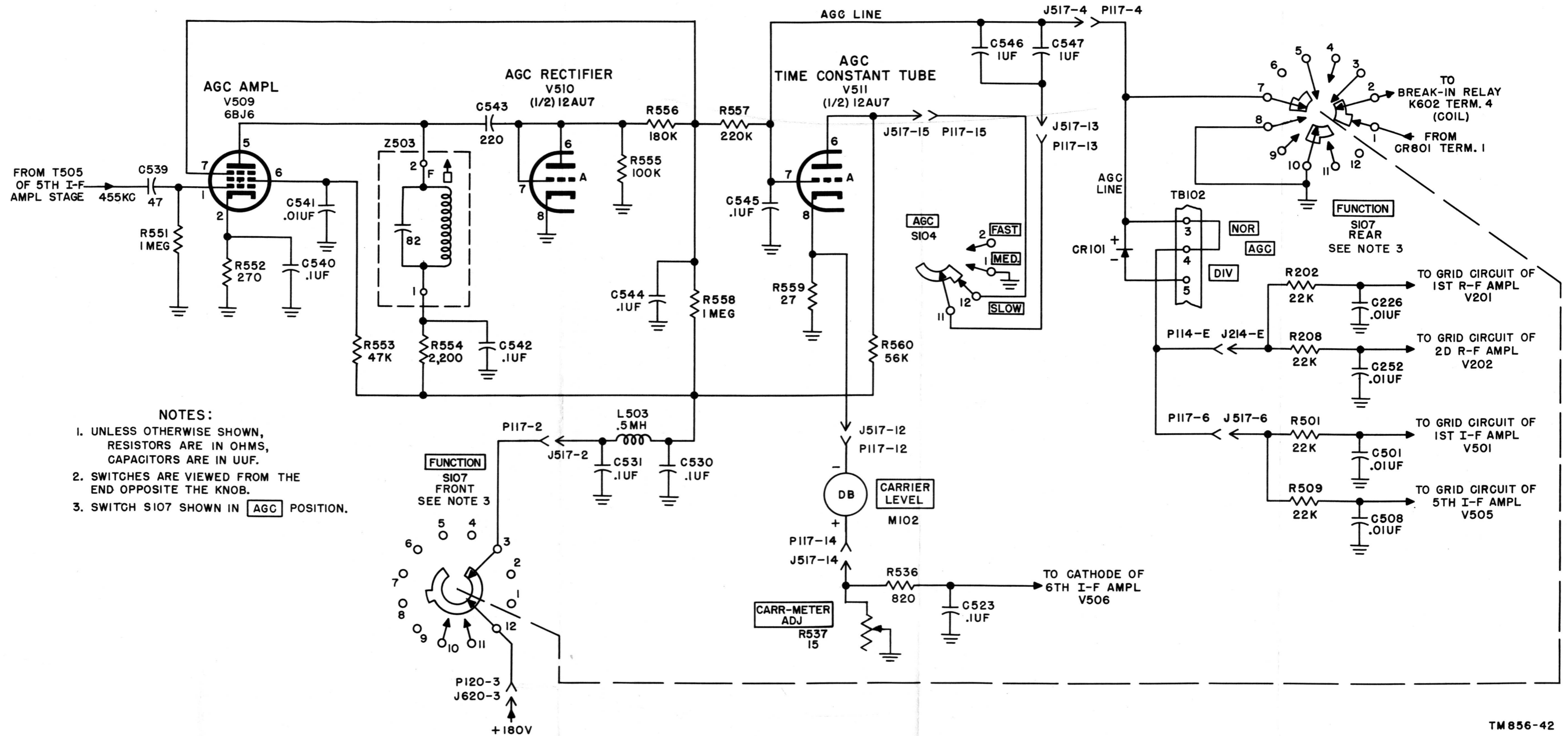
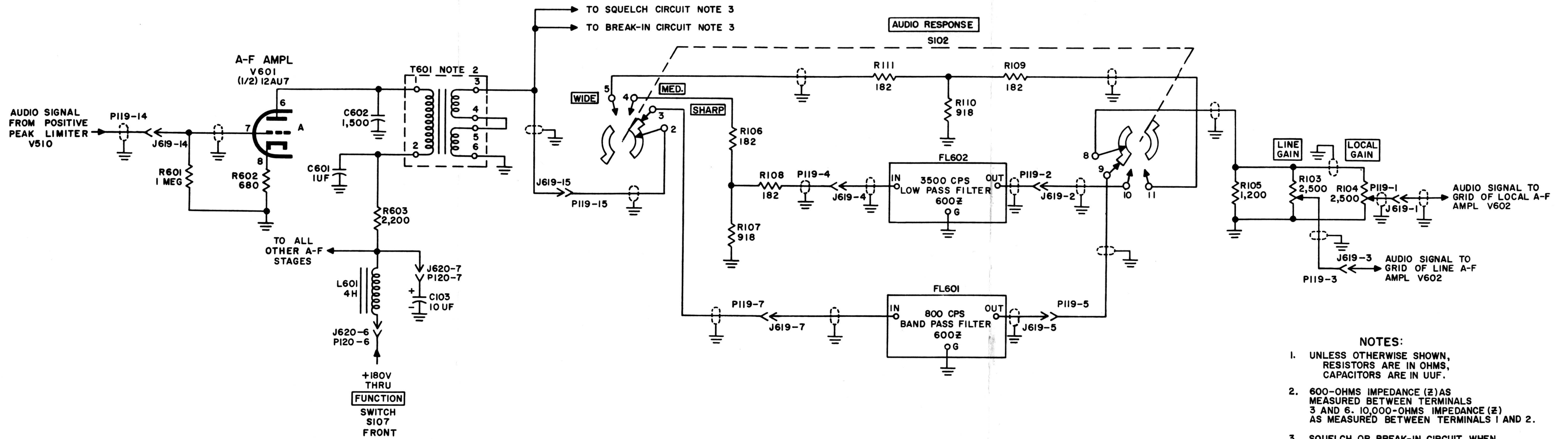

Figure 42. Agc circuit, schematic diagram.



- NOTES:
- UNLESS OTHERWISE SHOWN, RESISTORS ARE IN OHMS, CAPACITORS ARE IN UUF.
  - 600-OHMS IMPEDANCE (Z) AS MEASURED BETWEEN TERMINALS 3 AND 6. 10,000-OHMS IMPEDANCE (Z) AS MEASURED BETWEEN TERMINALS 1 AND 2.
  - SQUELCH OR BREAK-IN CIRCUIT WHEN ENERGIZED GROUNDS OUTPUT OF V601.
  - SWITCH IS VIEWED FROM THE END OPPOSITE THE KNOB.
  - SWITCH SIO2 SHOWN IN **SHARP** POSITION.

Figure 45. Af amplifier, schematic diagram.



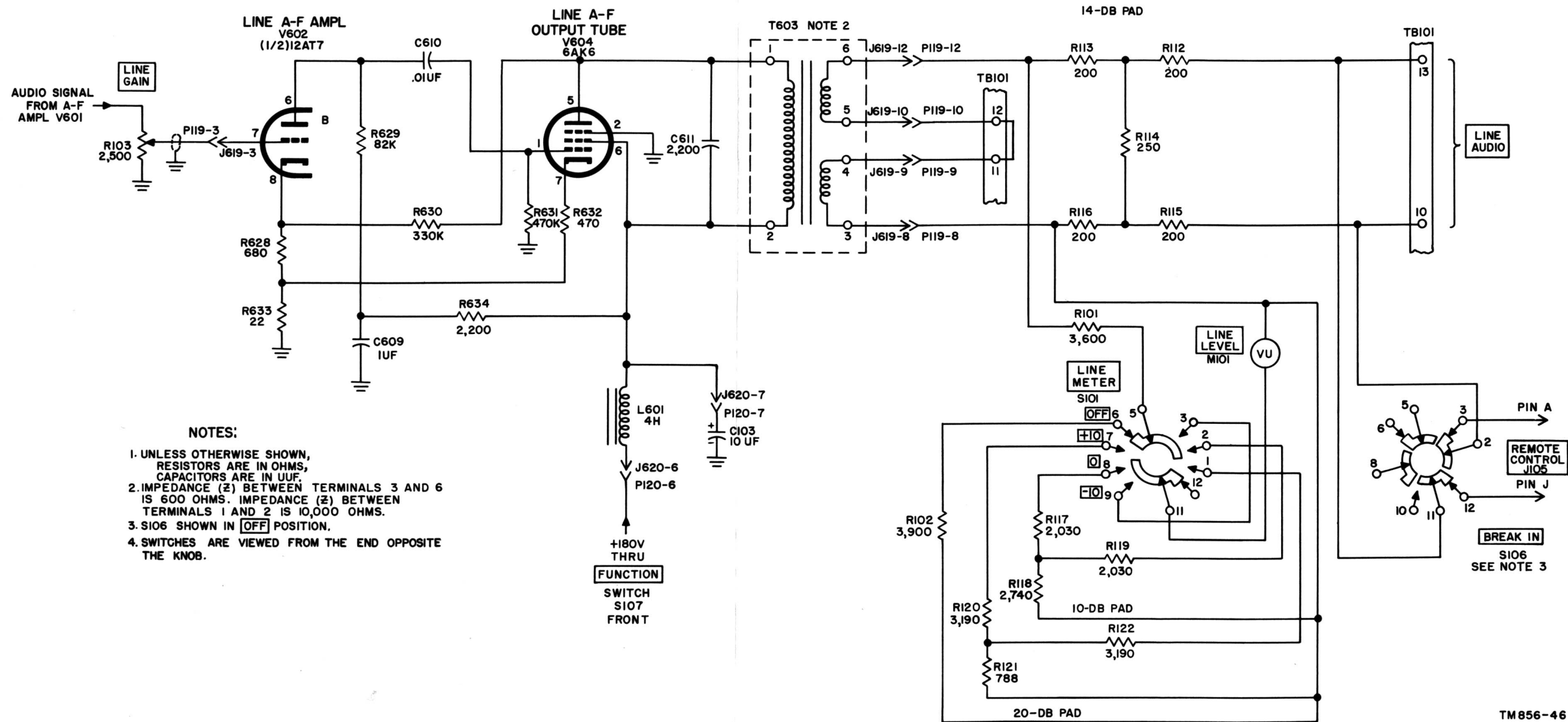

Figure 47. Line audio channel, schematic diagram.

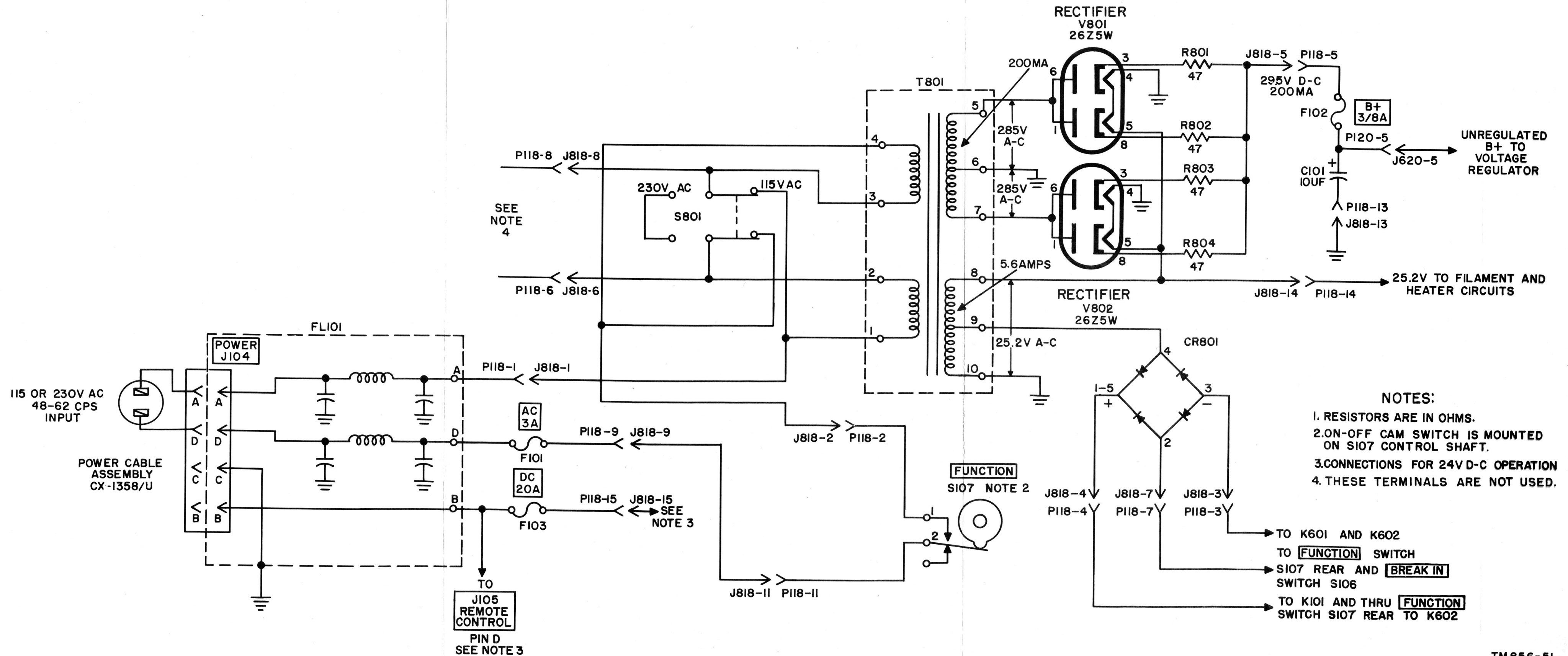

Figure 52. Power Supply PP-621/URR, schematic diagram.

- NOTES:**
1. UNLESS OTHERWISE SHOWN, RESISTORS ARE IN OHMS, CAPACITORS ARE IN UUF.
  2. SWITCHES ARE VIEWED FROM THE END OPPOSITE THE KNOB.
  3. SWITCH S107 IS IN **AGC** POSITION.

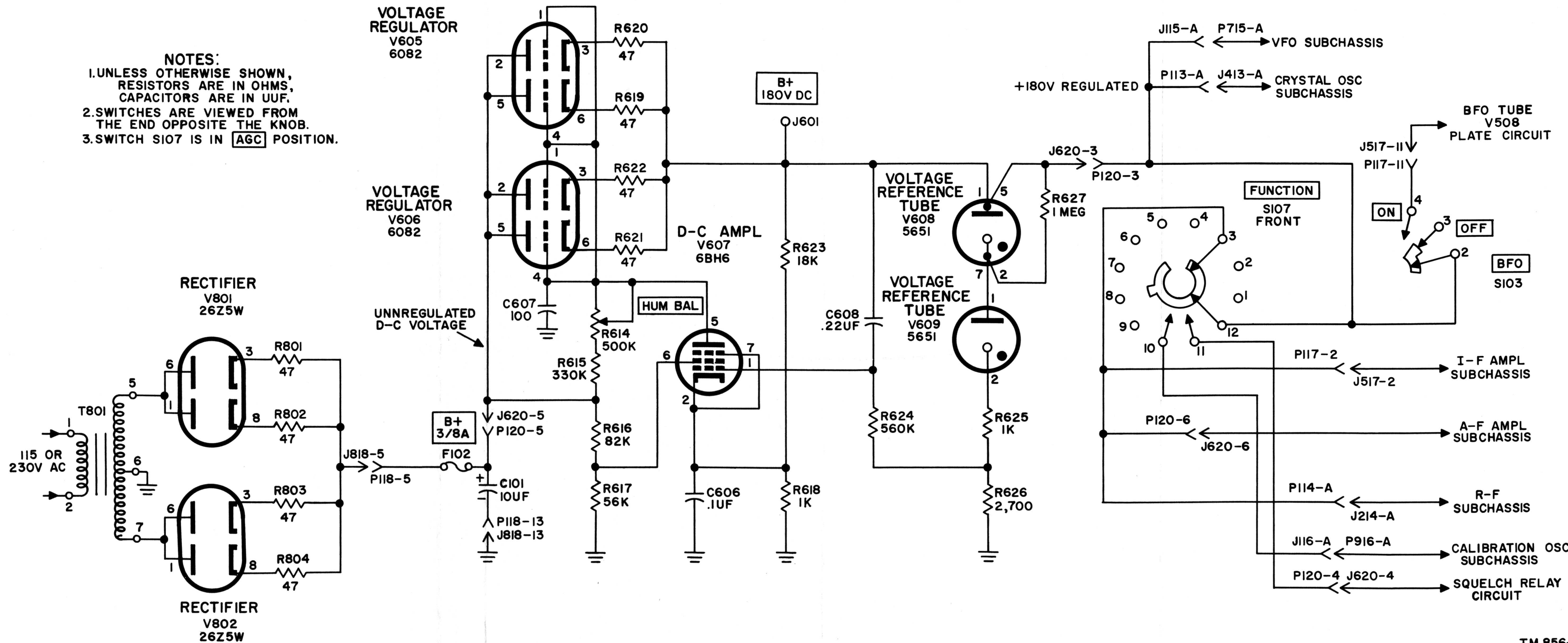
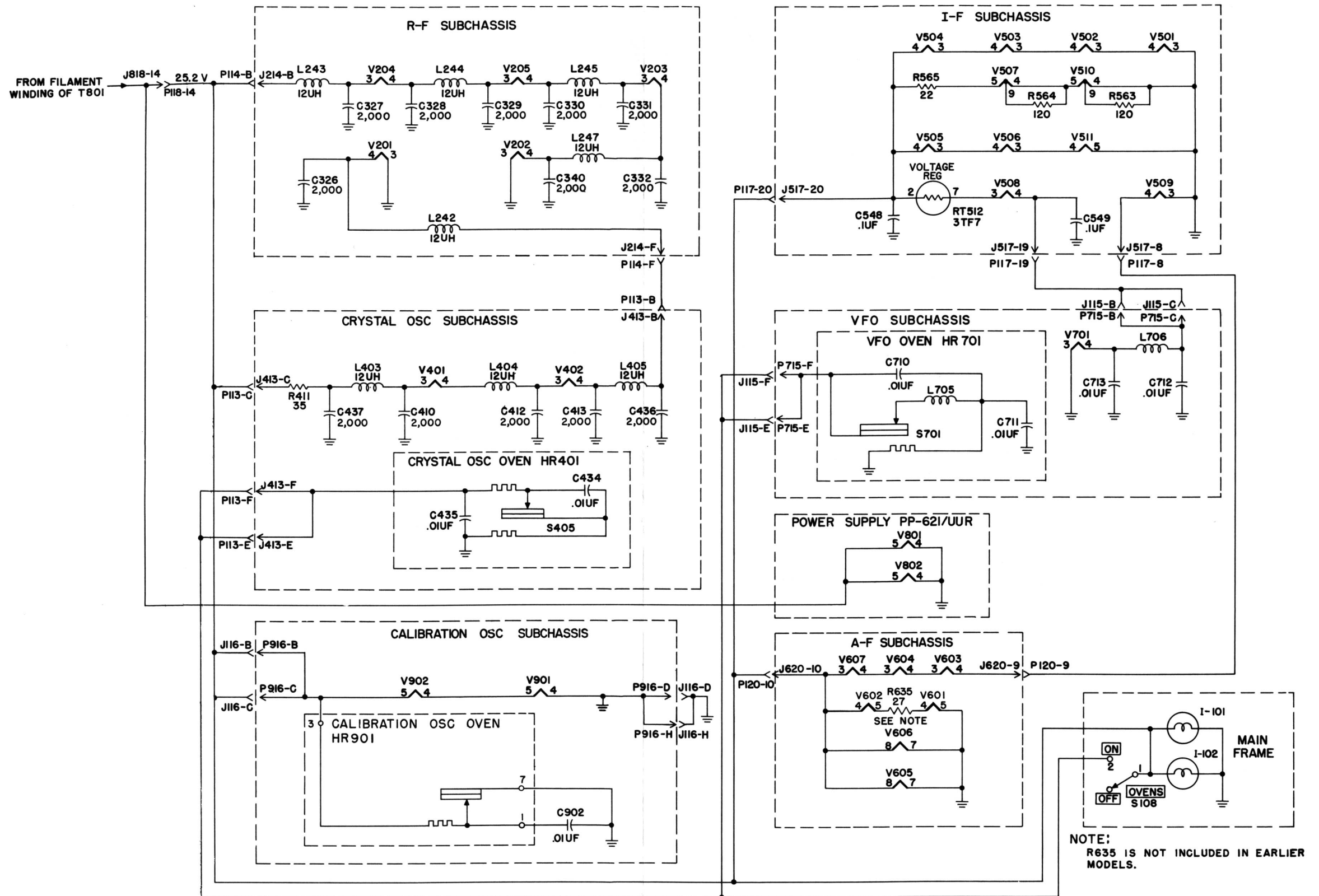

Figure 53. Voltage regulator circuit, schematic diagram.



NOTE:  
R635 IS NOT INCLUDED IN EARLIER  
MODELS.

Figure 54. Filament and oven heater circuits, schematic diagram.

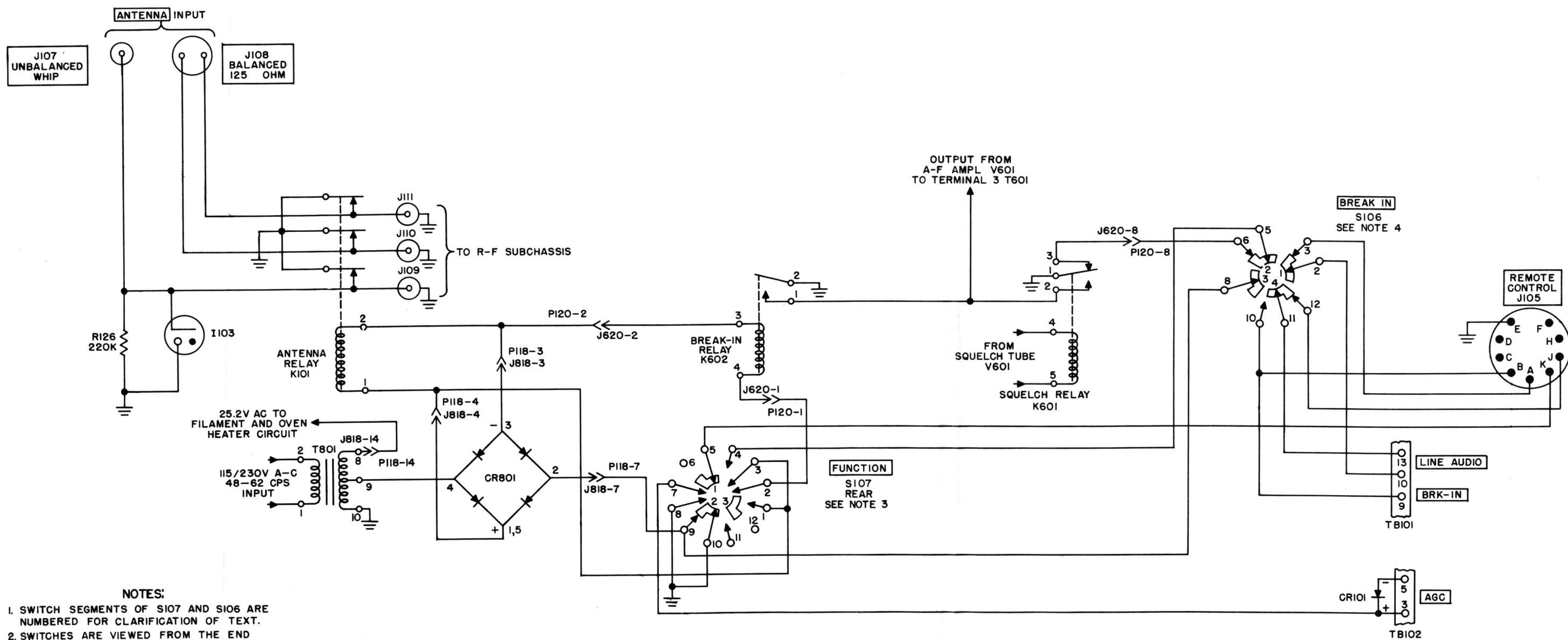

Figure 56. Break-in circuit, schematic diagram.

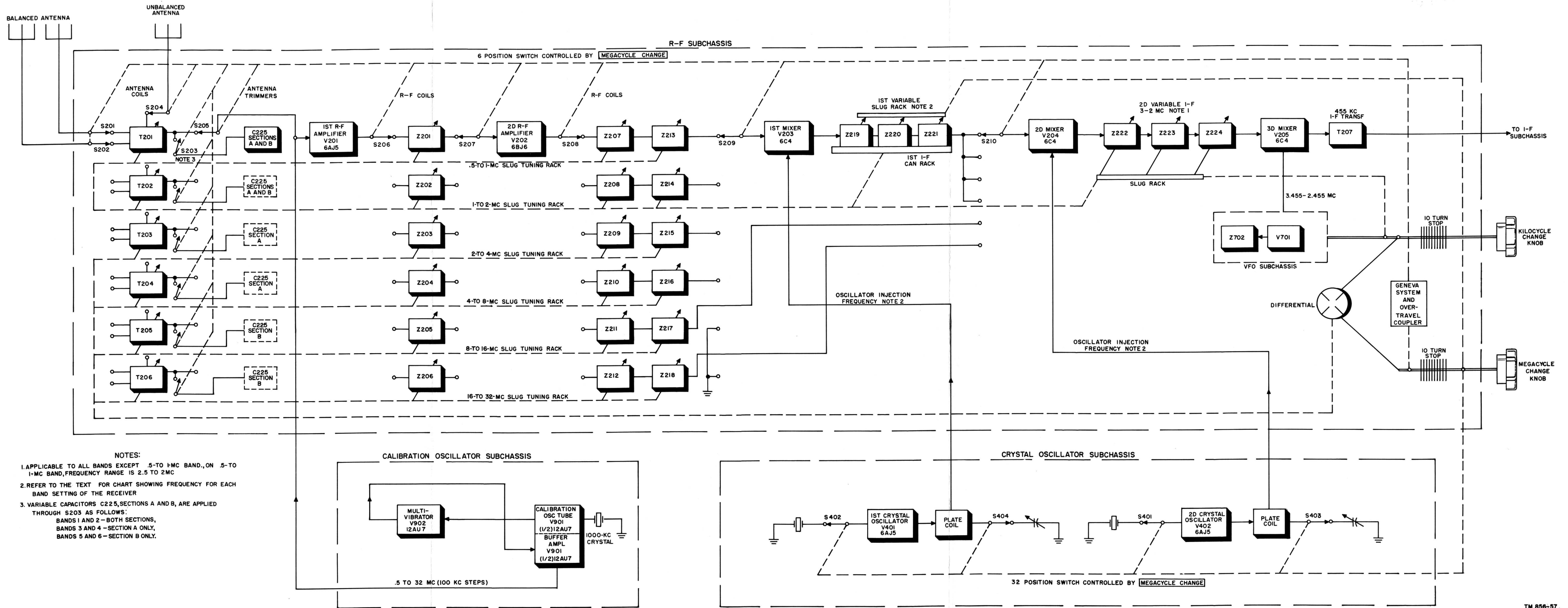
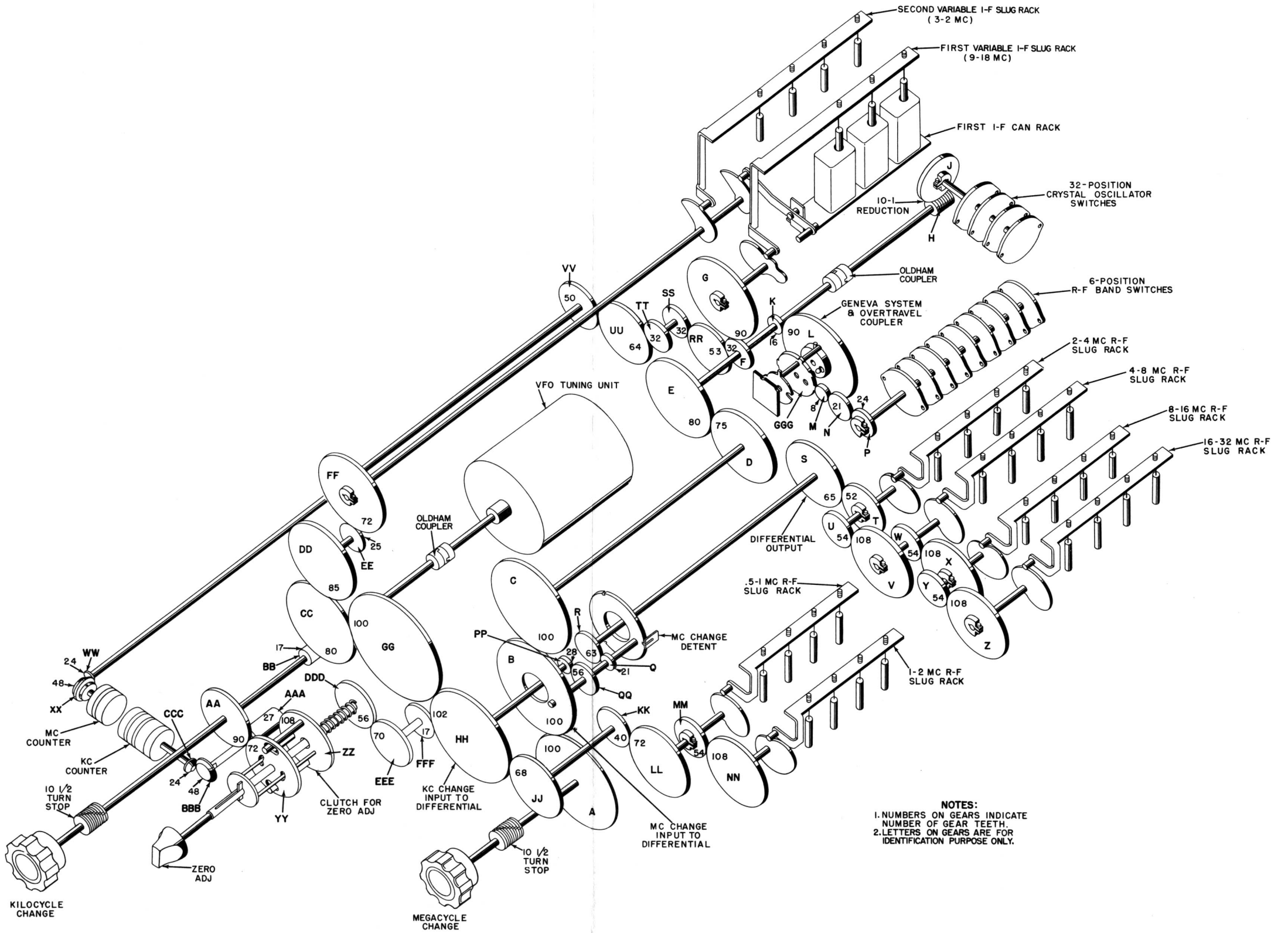

Figure 58. Mechanical tuning system with associated stages, block diagram.



NOTES:  
 1. NUMBERS ON GEARS INDICATE NUMBER OF GEAR TEETH.  
 2. LETTERS ON GEARS ARE FOR IDENTIFICATION PURPOSE ONLY.

Figure 59. Tuning system, exploded view.

NOTE:

INSTRUCTIONS ARE GIVEN BELOW, IN STEP-BY-STEP SEQUENCE, FOR ATTACHING RADIO FREQUENCY JACK UG-89/U TO ONE END OF THE CABLE. RADIO FREQUENCY PLUG UG-88/U IS ATTACHED TO OTHER END OF CABLE BY FOLLOWING SAME PROCEDURE AS FOR FEMALE CONNECTOR, EXCEPT THAT A MALE CONTACT AND PLUG BODY ARE SUBSTITUTED.

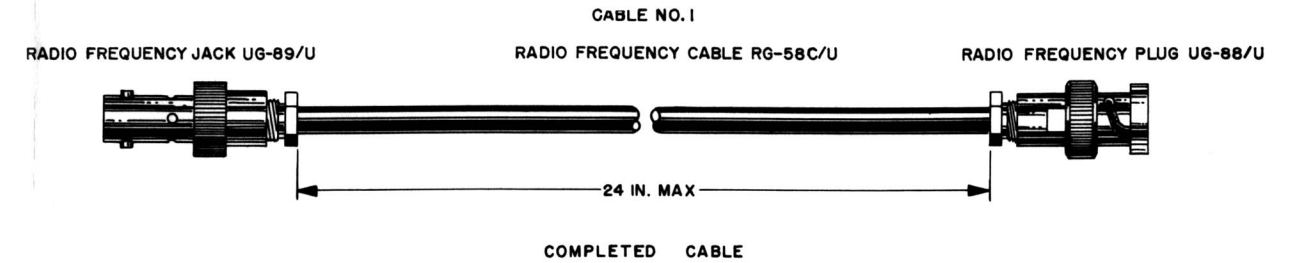

ASSEMBLING RADIO FREQUENCY JACK UG-89/U		NUT	SLEEVE	FEMALE CONTACT	JACK BODY				
STEP 1						CUT END OF CABLE EVEN.	STEP 6		WITH SLEEVE IN PLACE, COMB OUT BRAID, FOLD BACK SMOOTH AS SHOWN, AND TRIM 3/32".
STEP 2						REMOVE OUTER JACKET 1/2"—DON'T NICK BRAID.	STEP 7		BARE CENTER CONDUCTOR 1/8"—DON'T NICK CONDUCTOR.
STEP 3						PUSH BRAID BACK, AND REMOVE 1/8" OF INSULATION AND CONDUCTOR.	STEP 8		TIN CENTER CONDUCTOR OF CABLE. SLIP FEMALE CONTACT IN PLACE AND SOLDER. REMOVE EXCESS SOLDER. BE SURE CABLE DIELECTRIC IS NOT HEATED EXCESSIVELY AND SWOLLEN SO AS TO PREVENT DIELECTRIC ENTERING BODY.
STEP 4						TAPER BRAID.	STEP 9		PUSH INTO BODY AS FAR AS IT WILL GO. SLIDE NUT INTO BODY AND SCREW INTO PLACE, WITH WRENCH, UNTIL MODERATELY TIGHT. HOLD CABLE AND SHELL RIGIDLY AND ROTATE NUT.
STEP 5						SLIDE SLEEVE OVER TAPERED BRAID. FIT INNER SHOULDER OF SLEEVE SQUARELY AGAINST END OF JACKET.	STEP 10		ASSEMBLED CONNECTOR.

Figure 60. Assembly instruction for cable No. 1



**NOTES:**

1. THE MULTI-CONDUCTOR EXTENSION CABLES ARE TO BE FABRICATED OF NO. 18 TO 22 GAGE SHIELDED, STRANDED WIRE FOR AUDIO CONDUCTORS INDICATED BY  $\odot$ , NO. 18 GAGE STRANDED WIRE FOR CONDUCTORS MARKED  $\circ$ , AND NO. 22 GAGE STRANDED WIRE FOR ALL OTHER CONDUCTORS. INSULATION MUST BE RATED AT 600V.

2. CONNECTORS SHOWN VIEWED FROM REAR. COVERS TO BE USED WITH FEMALE CONNECTORS. AMPHENOL 86-834 COVER USED WITH 26-192 CONNECTOR.

3. CABLES TO BE LACED WITH NO. 6 VINYLITE LACING CORD AS SHOWN IN INSERT.

4. MAXIMUM LENGTH OF ALL CABLES IS 24 IN.

5. CHECK CONTINUITY AFTER COMPLETING FABRICATION.

6. LABEL EXTENSION CABLES FOR IDENTIFICATION.

7. NORMALLY, ONE EACH OF EXTENSION CABLES IS REQUIRED. IF VFO AND CALIBRATION OSC SUBCHASSIS ARE OPERATED OUTSIDE RECEIVER AT SAME TIME, TWO NO. 7 CABLES ARE NEEDED.

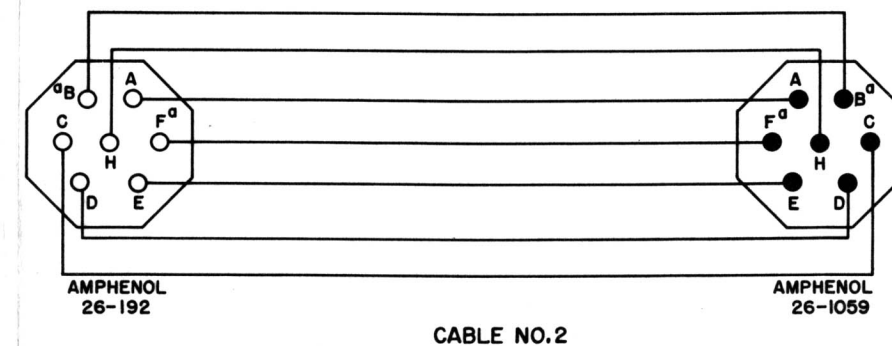
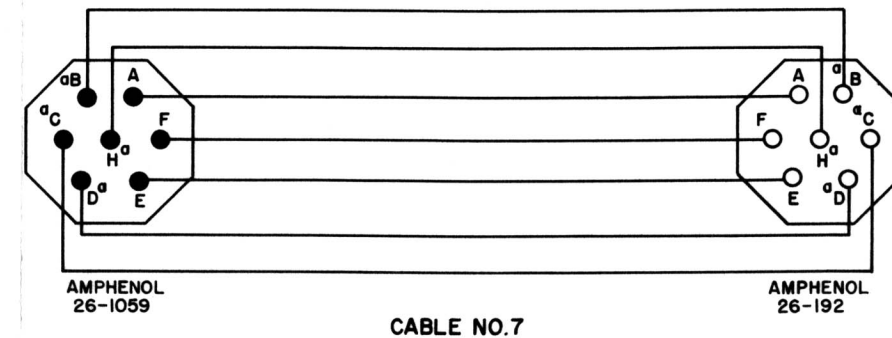
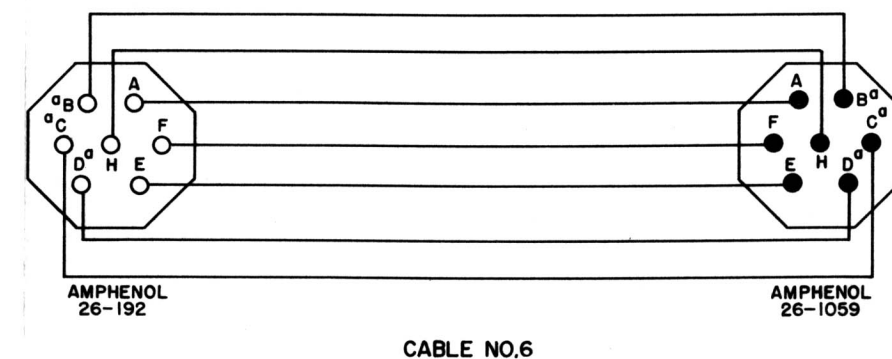
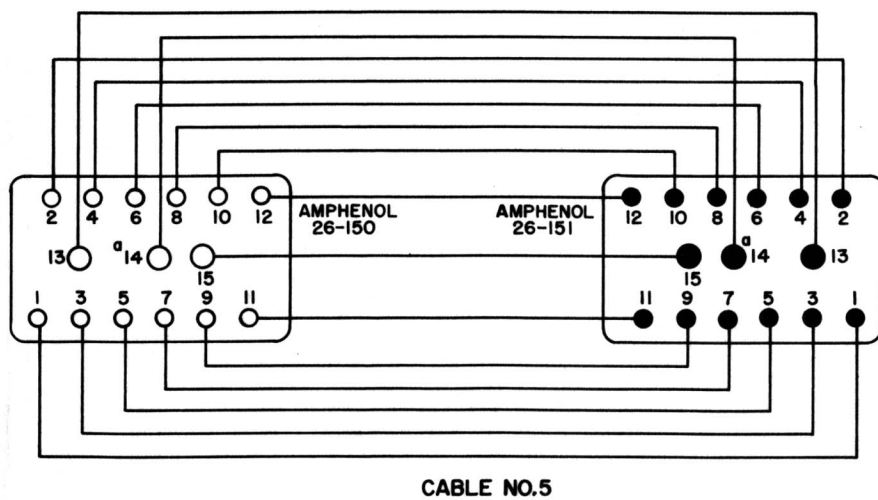
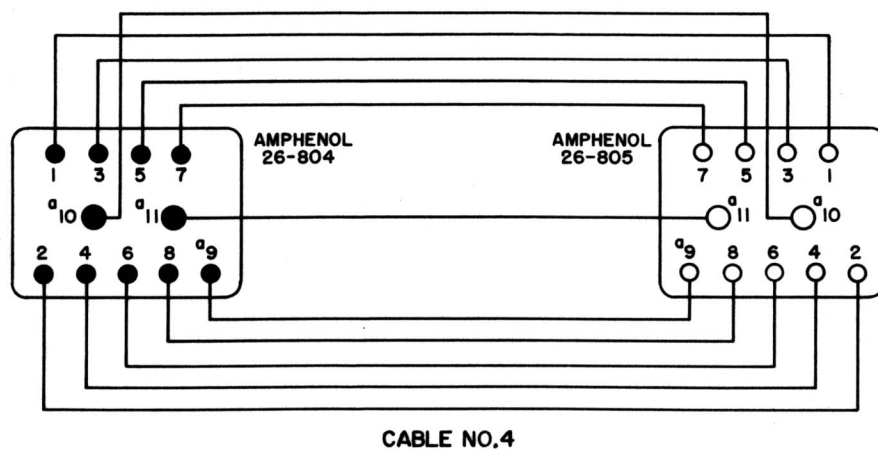
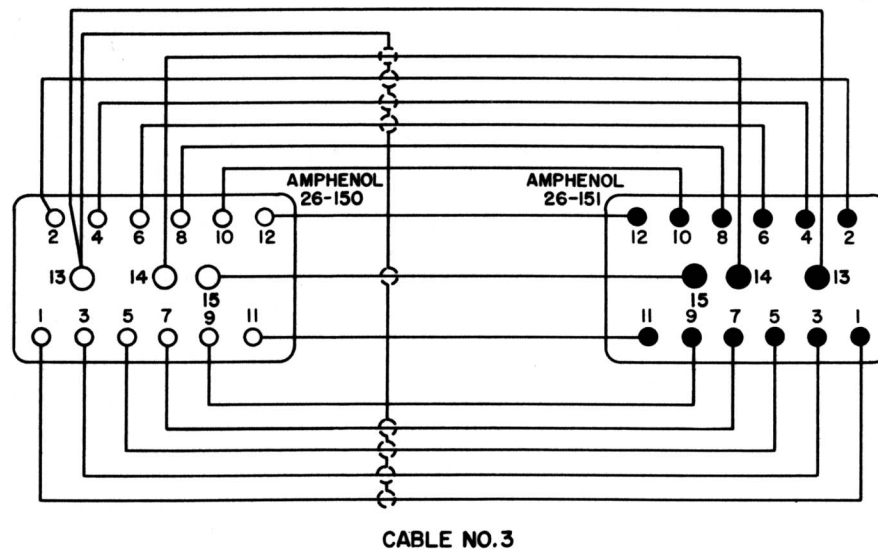
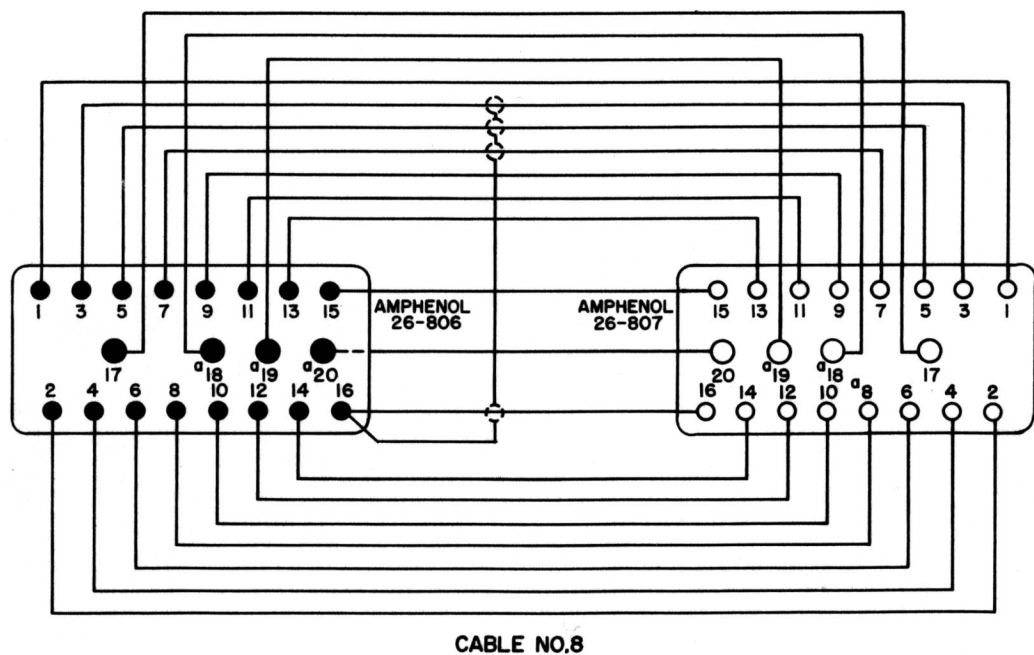
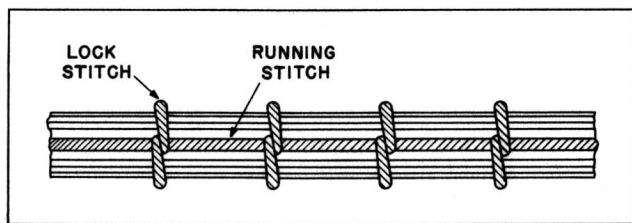
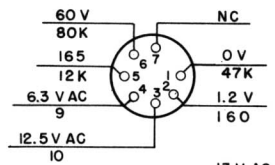
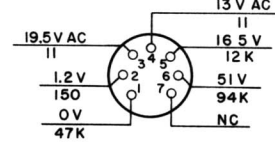

Figure 61. Assembly instructions for multiconductor cables.

REAR



2D CRYSTAL OSC  
V402  
6AJ5



1ST CRYSTAL OSC  
V401  
6AJ5

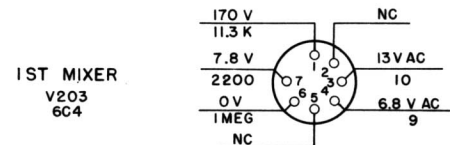
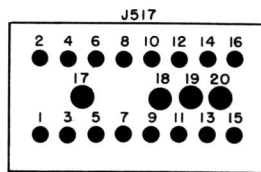

1ST MIXER  
V203  
6C4

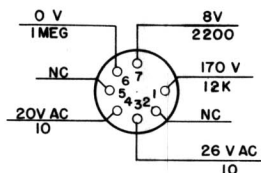

2D MIXER  
V204  
6C4

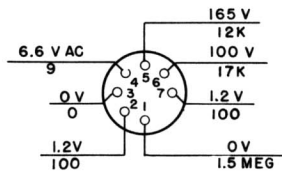

2D R-F AMPL  
V202  
6BJ6

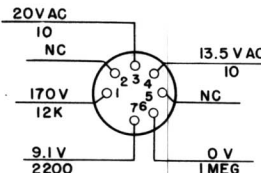

3D MIXER  
V205  
6C4

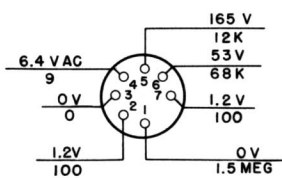

1ST R-F AMPL  
V201  
6AJ5

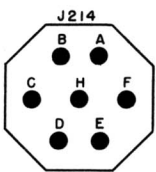
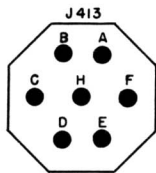

AGC RECTIFIER AND  
POSITIVE PEAK LIMITER  
V510A AND V510B  
12AU7

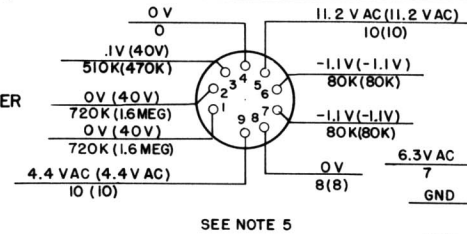

SEE NOTE 5

AGC AMPL  
V509  
6BJ6

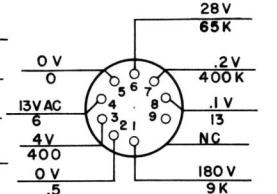

AGC TIME CONSTANT TUBE  
AND CATHODE FOLLOWER  
V511A AND V511B  
12AU7

6TH I-F AMPL  
V506  
6AK6

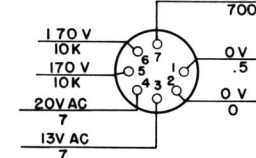

SEE NOTE 5

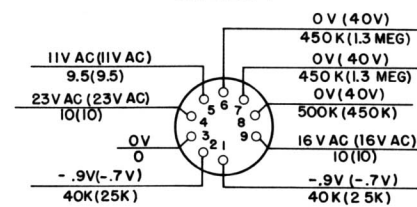

DETECTOR AND NEGATIVE  
PEAK LIMITER  
V507A AND V507B  
12AU7

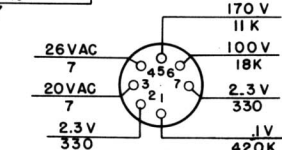

5TH I-F AMPL  
V505  
6BJ6

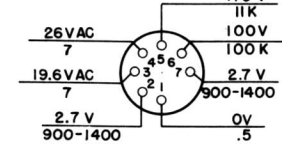

4TH I-F AMPL  
V504  
6BJ6

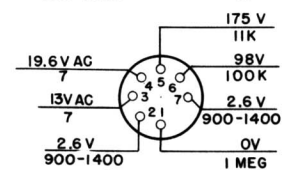

3D I-F AMPL  
V503  
6BJ6

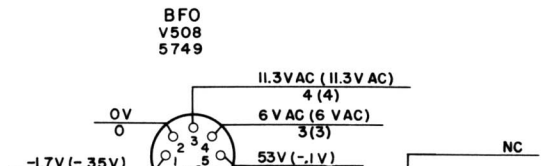

SEE NOTE 6

VOLTAGE REGULATOR  
RT512  
3TF7

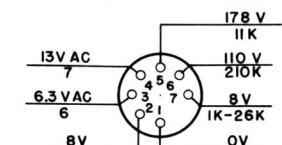

2D I-F AMPL  
V502  
6BJ6

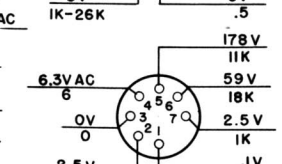

1ST I-F AMPL  
V501  
6BJ6

FRONT

1. UNLESS OTHERWISE SHOWN, RESISTORS ARE IN OHMS AND ARE MEASURED FROM PIN SOCKET TO GROUND WITH A 20,000 OHMS-PER-VOLT METER (SUCH AS MULTIMETER TS-352/U). VOLTAGES ARE DC AND ARE MEASURED FROM PIN SOCKET TO GROUND WITH A VTVM (SUCH AS ELECTRONIC MULTIMETER TS-503/U). READINGS ARE THE SAME ON ALL BANDS.  
2. NC INDICATES NO CONNECTION  
3. ∞ INDICATES INFINITY

NOTES:

- 4. UNLESS OTHERWISE NOTED, SET CONTROLS AS FOLLOWS: SET S801 TO 115 VOLTS AC, FUNCTION TO AGC, AUDIO RESPONSE TO MED, RF GAIN TO 10, LOCAL GAIN TO 10, AND BANDWIDTH TO 8 KC.
- 5. READINGS IN PARENTHESES ARE MADE WITH LIMITER AT OFF, OTHER READINGS ARE WITH LIMITER AT 10.
- 6. READINGS IN PARENTHESES ARE MADE WITH BFO AT OFF.
- 7. RECEPTACLE RESISTANCE READINGS ARE TAKEN WITH PLUG DISCONNECTED.

Figure 82. Radio Receiver R-390/URR, tube voltage and resistance and subchassis receptacle resistance diagram, top deck.

REAR

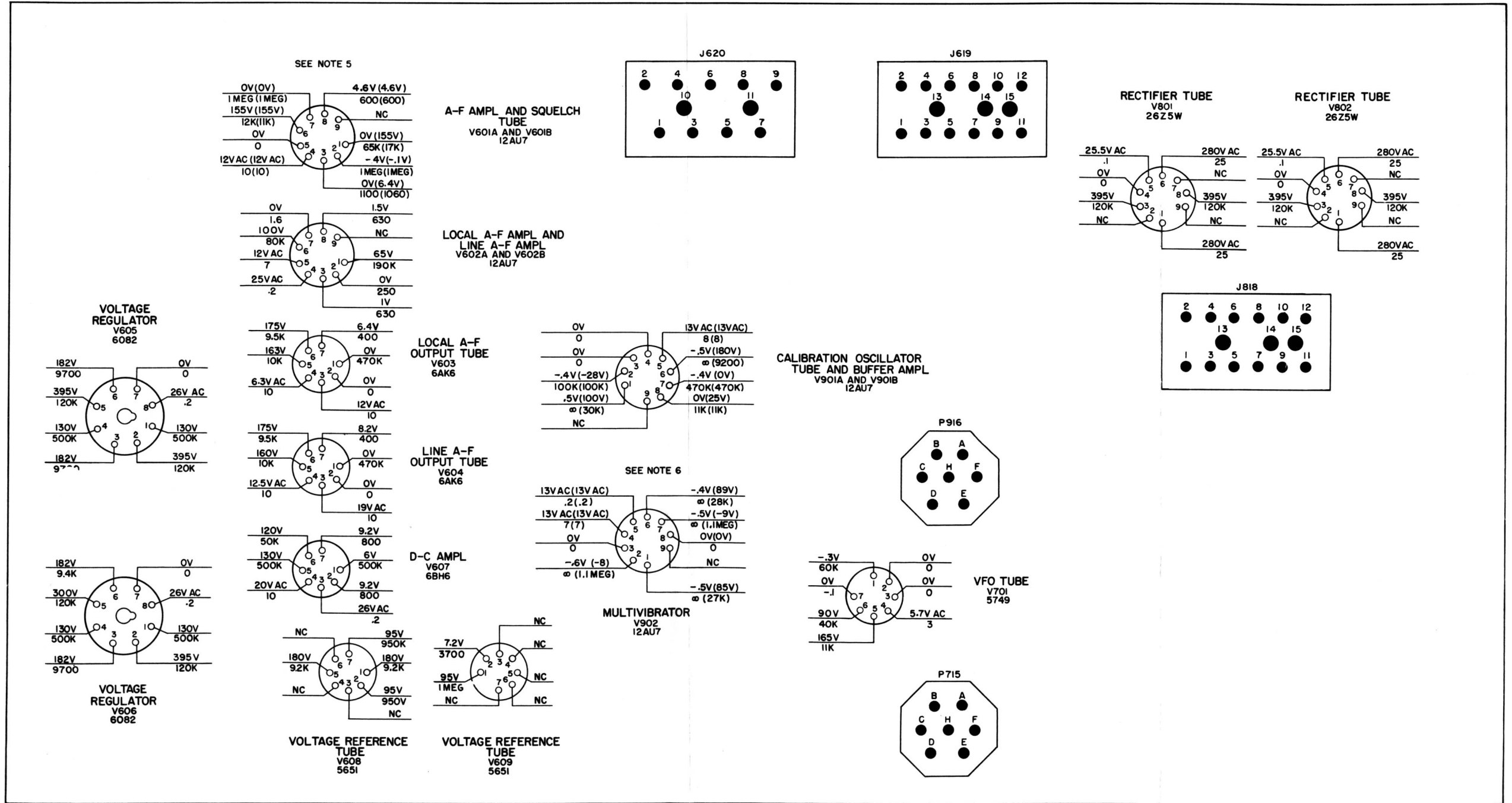

FRONT

NOTES:

- UNLESS OTHERWISE SHOWN RESISTORS ARE IN OHMS AND ARE MEASURED FROM PIN SOCKET TO GROUND WITH A 20,000 OHM-PER-VOLT METER (SUCH AS MULTIMETER TS-352/U). VOLTAGES ARE DC AND ARE MEASURED FROM PIN SOCKET TO GROUND WITH A VTVM (SUCH AS TRIPLETT ELECTRONIC MULTIMETER TS-505/U). READINGS ARE THE SAME ON ALL BANDS.
- NC INDICATES NO CONNECTION.
- ∞ INDICATES INFINITY.
- UNLESS OTHERWISE NOTED, SET CONTROLS AS FOLLOWS: SET S801 TO 115 VOLTS AC, [FUNCTION] TO [AGC] [AUDIO RESPONSE] TO [MED], [RF GAIN] TO [10] [LOCAL GAIN] TO [10], AND [BANDWIDTH] TO [BKC].
- READING IN PARENTHESES ARE MADE WITH [SQUELCH] AT [ON].
- READINGS IN PARENTHESES ARE MADE WITH [FUNCTION] AT [CAL].
- RECEPTACLE RESISTANCE READINGS ARE TAKEN WITH PLUG DISCONNECTED.

Figure 83. Radio Receiver R-390/URR, tube voltage and resistance and subchassis receptacle resistance diagram, bottom deck.

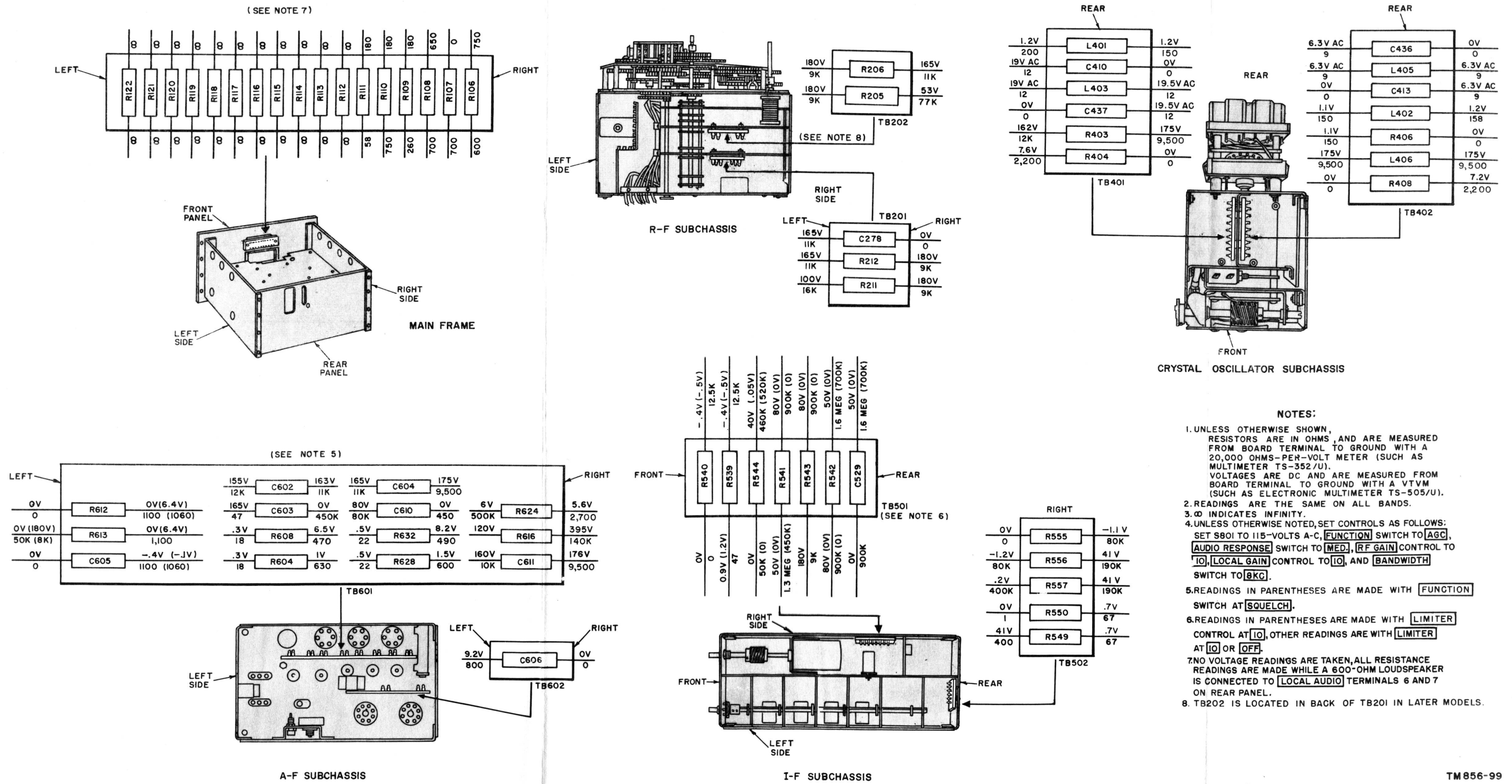

- NOTES:
- UNLESS OTHERWISE SHOWN, RESISTORS ARE IN OHMS, AND ARE MEASURED FROM BOARD TERMINAL TO GROUND WITH A 20,000 OHMS-PER-VOLT METER (SUCH AS MULTIMETER TS-352/U). VOLTAGES ARE DC AND ARE MEASURED FROM BOARD TERMINAL TO GROUND WITH A VTVM (SUCH AS ELECTRONIC MULTIMETER TS-505/U).
  - READINGS ARE THE SAME ON ALL BANDS.
  - ∞ INDICATES INFINITY.
  - UNLESS OTHERWISE NOTED, SET CONTROLS AS FOLLOWS: SET S801 TO 115-VOLTS A-C, **FUNCTION** SWITCH TO **AGC**, **AUDIO RESPONSE** SWITCH TO **MED.**, **RF GAIN** CONTROL TO **10**, **LOCAL GAIN** CONTROL TO **10**, AND **BANDWIDTH** SWITCH TO **8KC**.
  - READINGS IN PARENTHESES ARE MADE WITH **FUNCTION** SWITCH AT **SQUELCH**.
  - READINGS IN PARENTHESES ARE MADE WITH **LIMITER** CONTROL AT **10**, OTHER READINGS ARE WITH **LIMITER** AT **10** OR **OFF**.
  - NO VOLTAGE READINGS ARE TAKEN, ALL RESISTANCE READINGS ARE MADE WHILE A 600-OHM LOUDSPEAKER IS CONNECTED TO **LOCAL AUDIO** TERMINALS 6 AND 7 ON REAR PANEL.
  - TB202 IS LOCATED IN BACK OF TB201 IN LATER MODELS.

Figure 84. Radio Receiver R-390/URR, terminal boards voltage and resistance diagram.

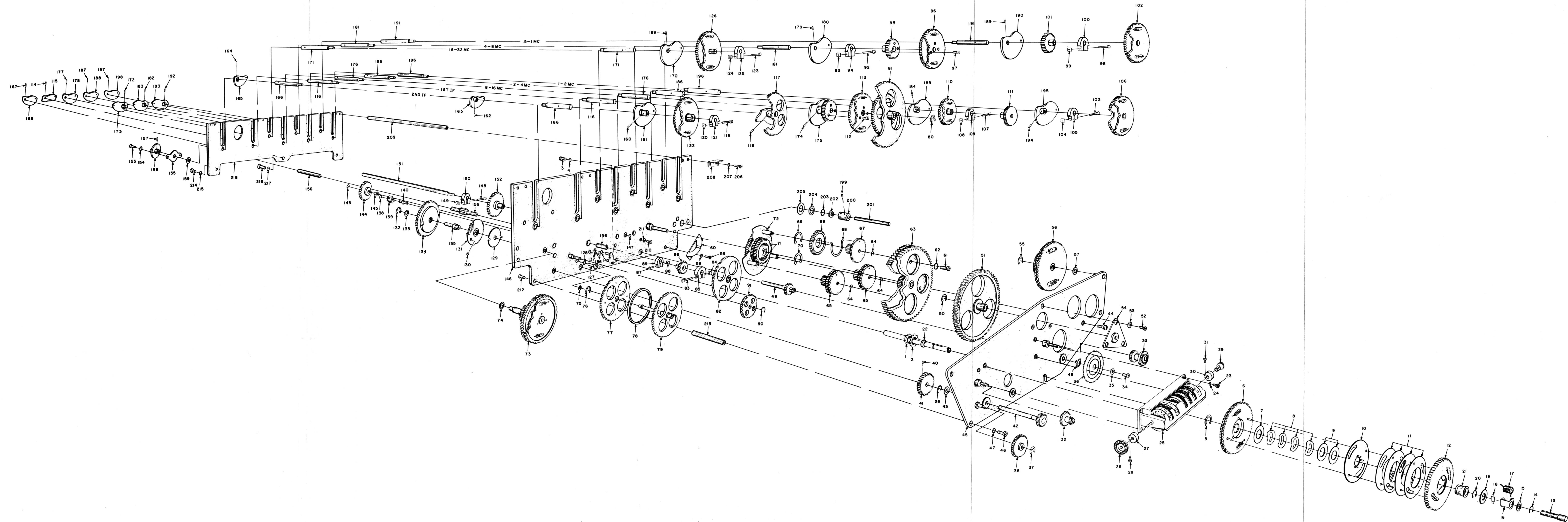

Figure 88.1. (Added) RF gear train, exploded view.

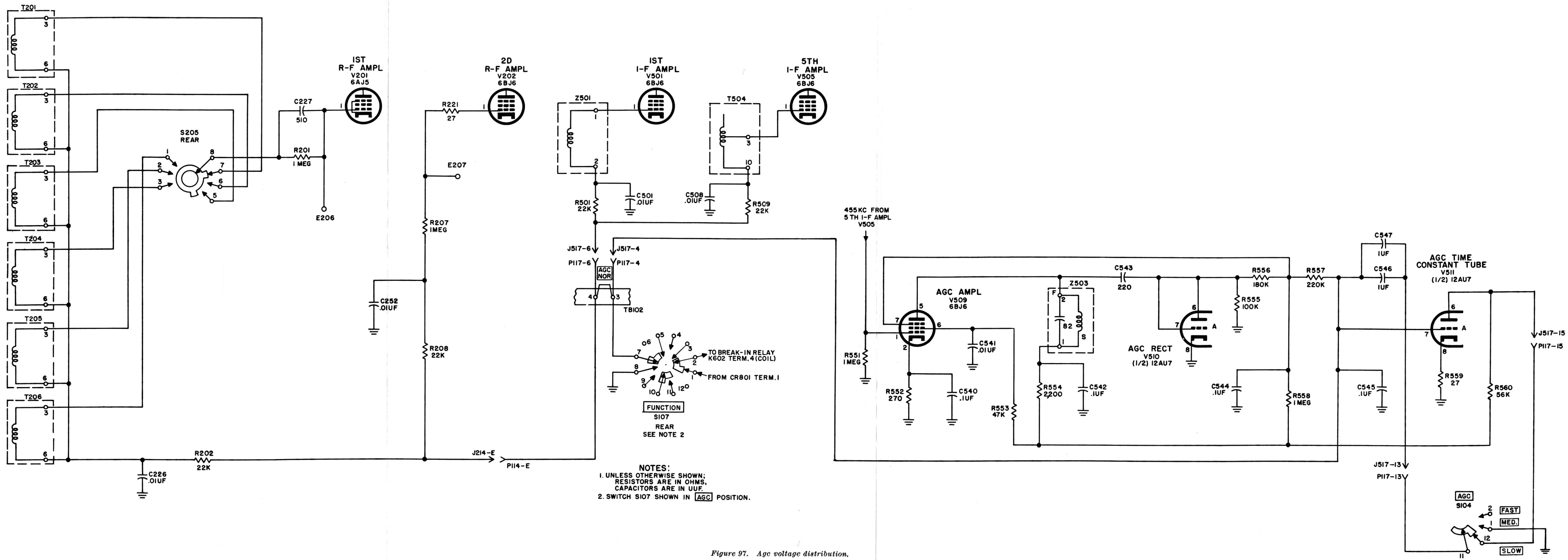

Figure 97. Agc voltage distribution.

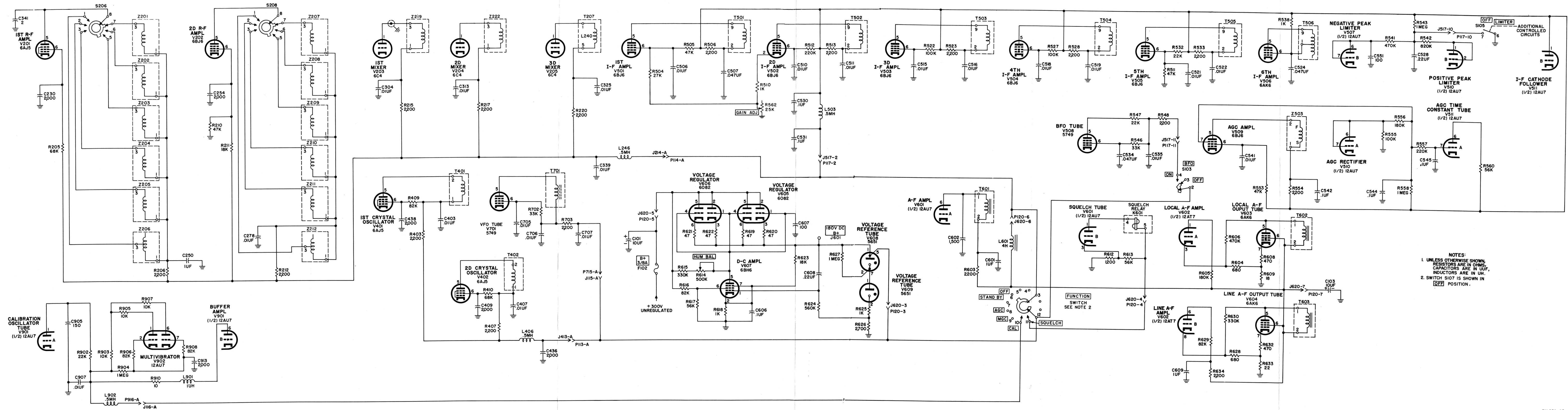

Figure 98. B+ voltage distribution.

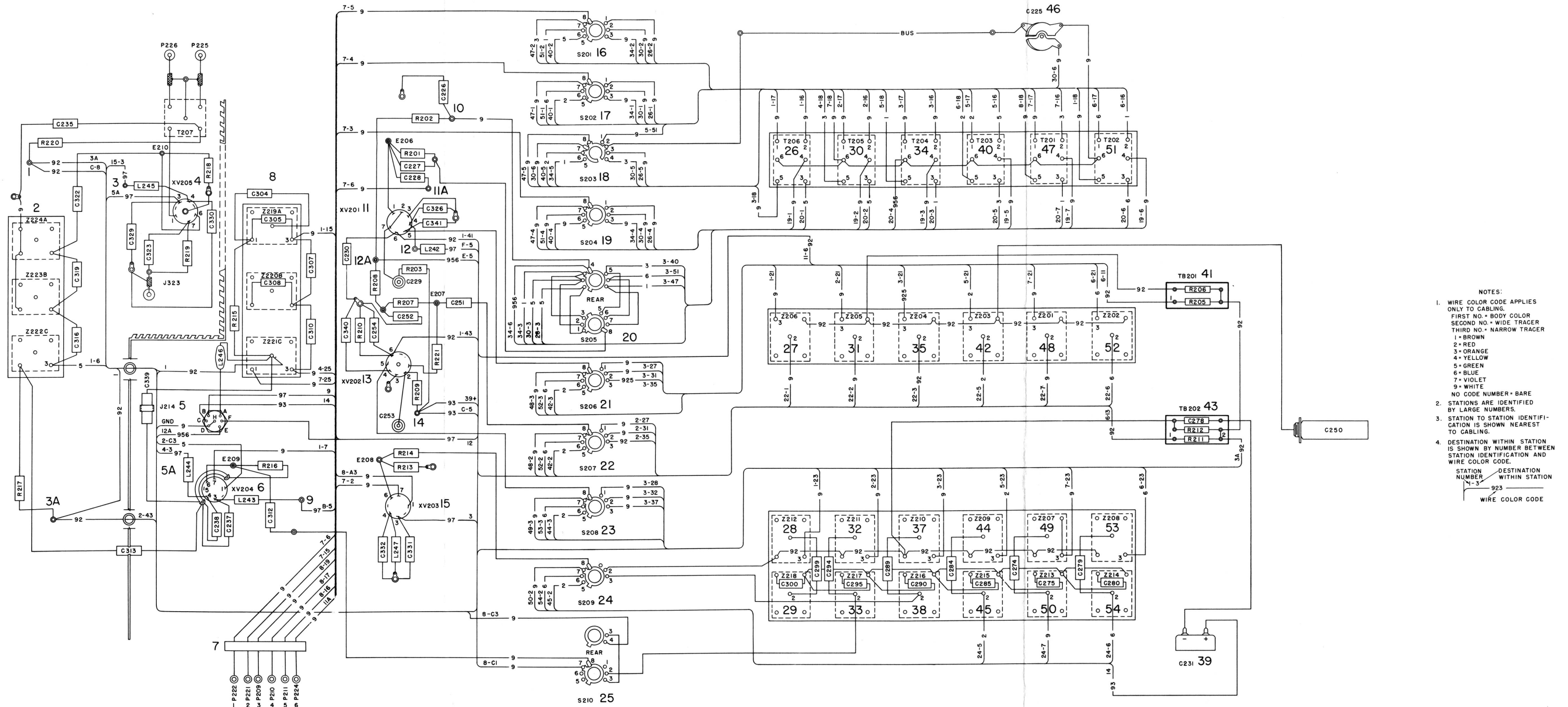

Figure 99. Radio Receiver R-390/URR, rf subchassis, wiring diagram.



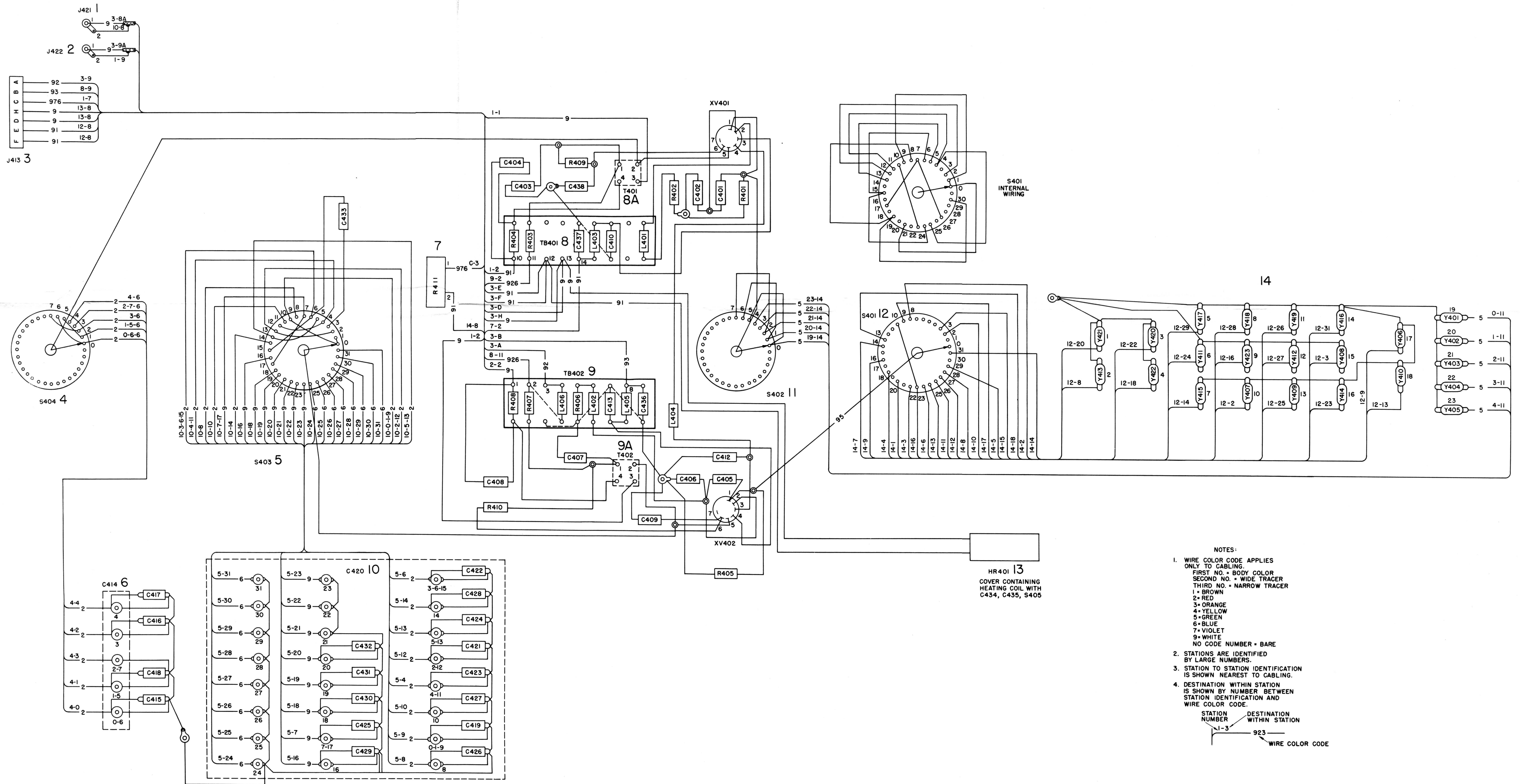
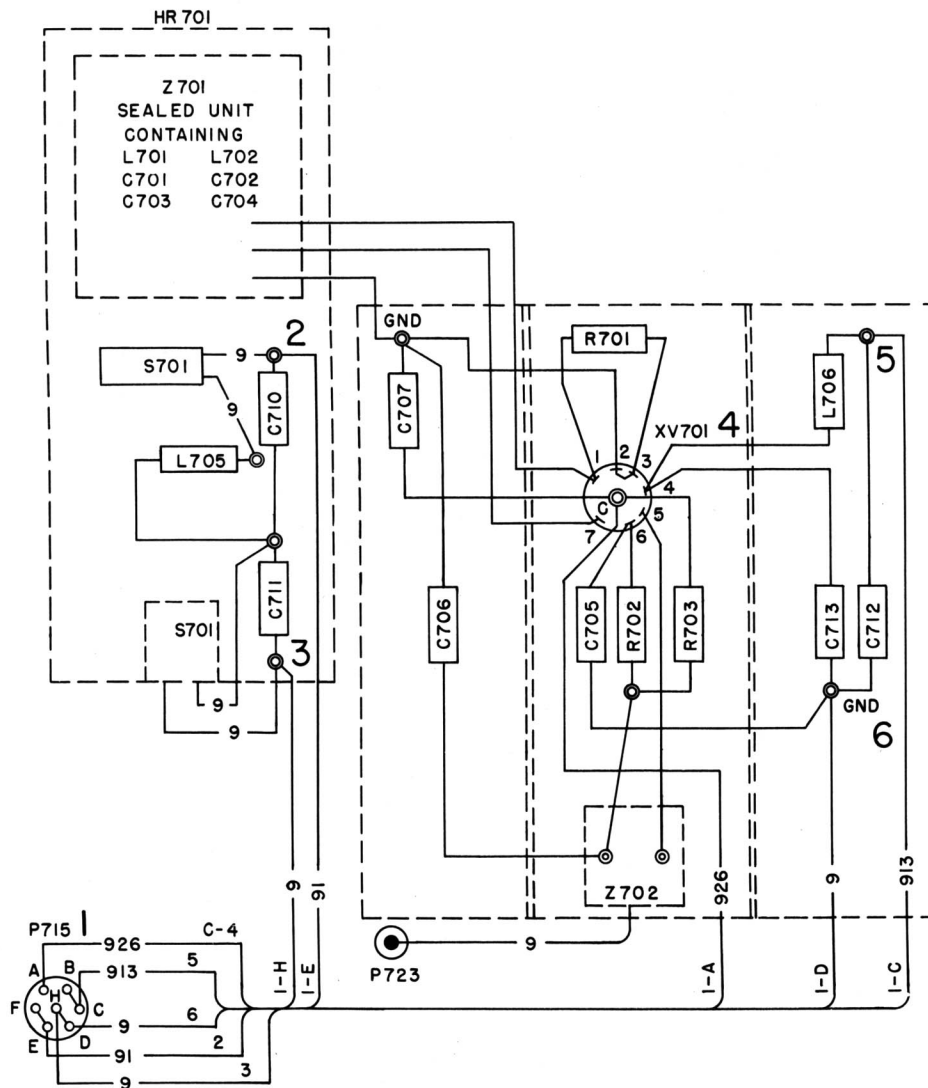
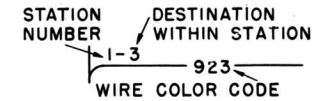

Figure 100. Radio Receiver R-390/URR, crystal oscillator subchassis, wiring diagram.



NOTES:

1. WIRE COLOR CODE APPLIES ONLY TO CABLING.  
FIRST NO. = BODY COLOR  
SECOND NO. = WIDE TRACER  
THIRD NO. = NARROW TRACER  
1 = BROWN  
2 = RED  
3 = ORANGE  
4 = YELLOW  
5 = GREEN  
6 = BLUE  
7 = VIOLET  
9 = WHITE  
NO CODE NUMBER = BARE
2. STATIONS ARE IDENTIFIED BY LARGE NUMBERS.
3. STATION TO STATION IDENTIFICATION IS SHOWN NEAREST TO CABLING.
4. DESTINATION WITHIN STATION IS SHOWN BY NUMBER BETWEEN STATION IDENTIFICATION AND WIRE COLOR CODE.



TM 856-106

Figure 101. Radio Receiver R-390/URR, variable frequency oscillator subchassis, wiring diagram.

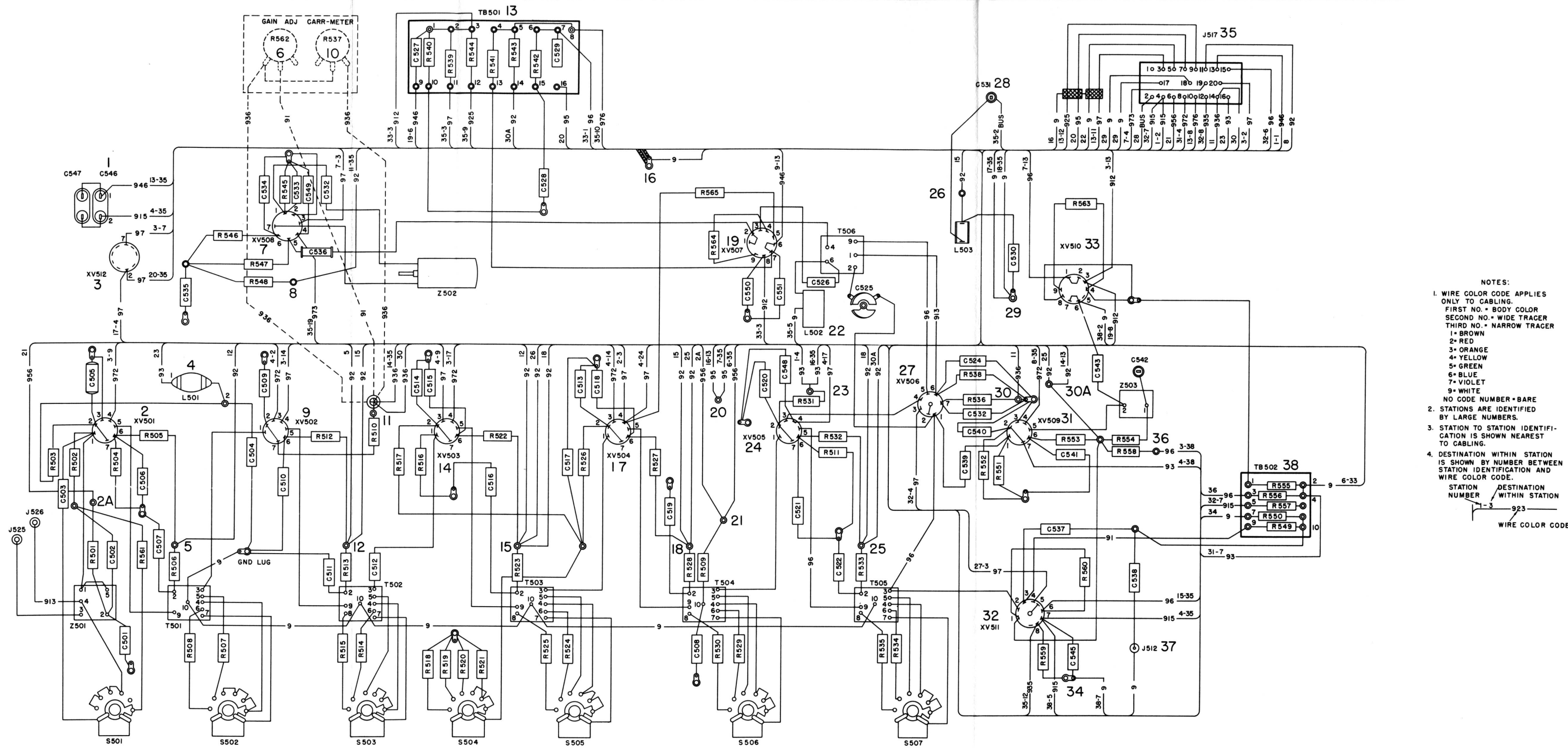

- NOTES:
1. WIRE COLOR CODE APPLIES ONLY TO CABLING.  
FIRST NO. = BODY COLOR  
SECOND NO. = WIDE TRACER  
THIRD NO. = NARROW TRACER  
1 = BROWN  
2 = RED  
3 = ORANGE  
4 = YELLOW  
5 = GREEN  
6 = BLUE  
7 = VIOLET  
9 = WHITE  
NO CODE NUMBER = BARE
  2. STATIONS ARE IDENTIFIED BY LARGE NUMBERS.
  3. STATION TO STATION IDENTIFICATION IS SHOWN NEAREST TO CABLING.
  4. DESTINATION WITHIN STATION IS SHOWN BY NUMBER BETWEEN STATION IDENTIFICATION AND WIRE COLOR CODE.
- STATION NUMBER      DESTINATION WITHIN STATION  
 1-3      9-23  
 WIRE COLOR CODE

Figure 102. Radio Receiver R-390/URR, if. subchassis wiring diagram.

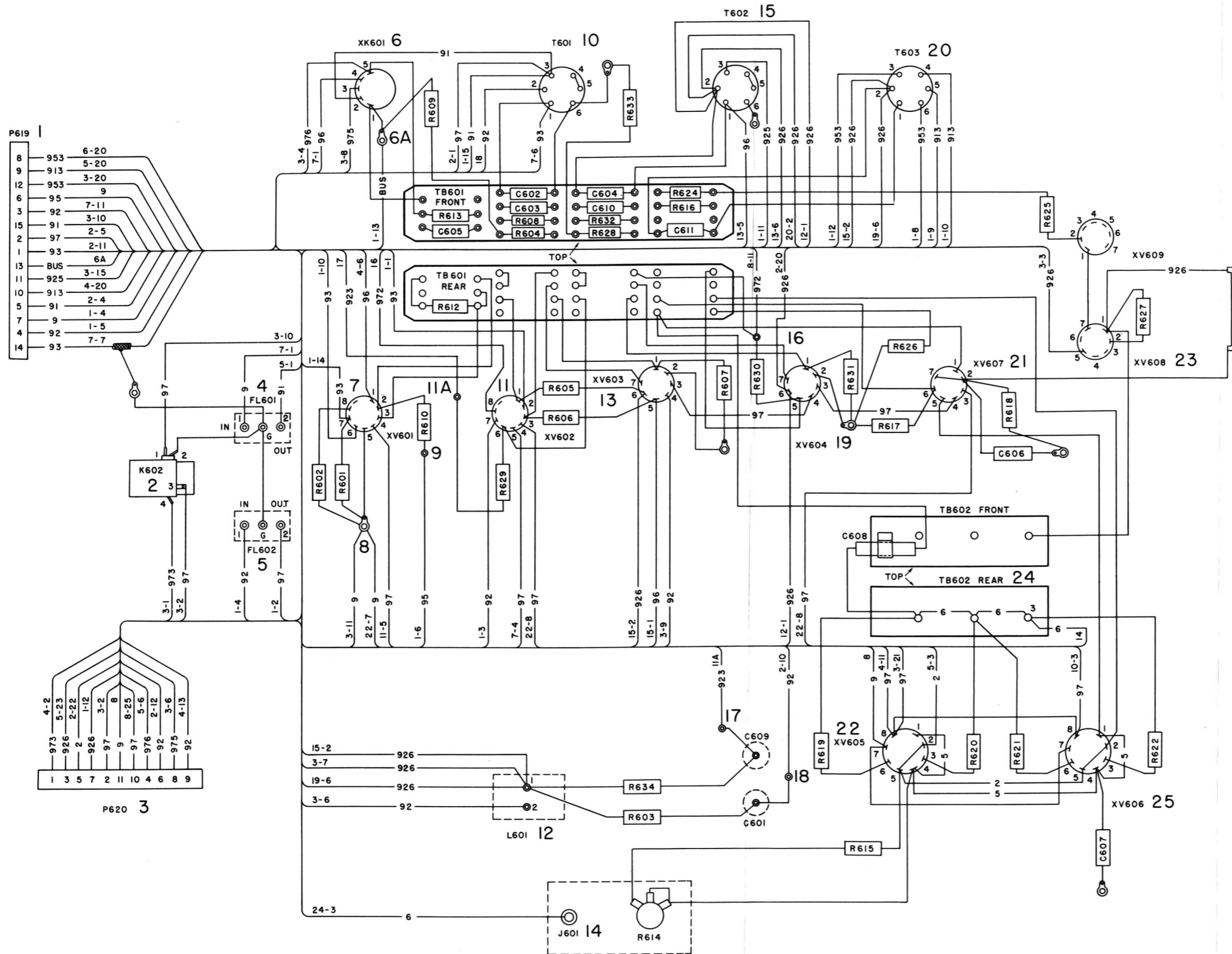

- NOTES:
1. WIRE COLOR CODE APPLIES ONLY TO CABLING. FIRST NO. - BODY COLOR SECOND NO. - WIDE TRACER THIRD NO. - NARROW TRACER  
 1 = BROWN  
 2 = RED  
 3 = ORANGE  
 4 = YELLOW  
 5 = GREEN  
 6 = BLUE  
 7 = VIOLET  
 9 = WHITE  
 NO CODE NUMBER - BARE
  2. STATIONS ARE IDENTIFIED BY LARGE NUMBERS.
  3. STATION TO STATION IDENTIFICATION IS SHOWN NEAREST TO CABLING.
  4. DESTINATION WITHIN STATION IS SHOWN BY NUMBER BETWEEN STATION IDENTIFICATION AND WIRE COLOR CODE.
- | STATION NUMBER | DESTINATION WITHIN STATION | WIRE COLOR CODE |
|----------------|----------------------------|-----------------|
| 1-3            | 923                        |                 |

Figure 103. Radio Receiver R-390/URR, of subchassis, wiring diagram.

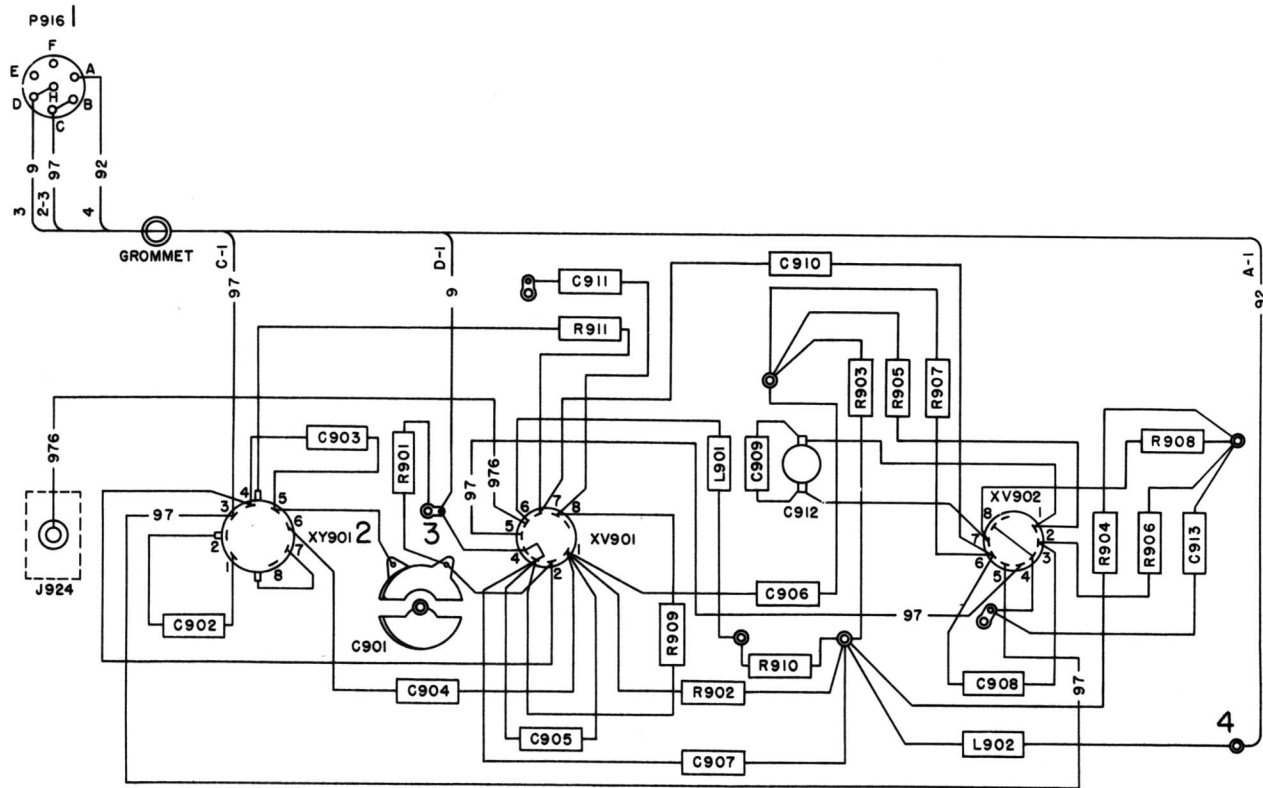

- NOTES:
1. WIRE COLOR CODE APPLIES ONLY TO CABLING.  
FIRST NO. - BODY COLOR  
SECOND NO. - WIDE TRACER  
THIRD NO. - NARROW TRACER  
1 - BROWN  
2 - RED  
3 - ORANGE  
4 - YELLOW  
5 - GREEN  
6 - BLUE  
7 - VIOLET  
8 - WHITE  
9 - WHITE  
NO CODE NUMBER - BARE
  2. STATIONS ARE IDENTIFIED BY LARGE NUMBERS.
  3. STATION TO STATION IDENTIFICATION IS SHOWN NEAREST TO CABLING.
  4. DESTINATION WITHIN STATION IS SHOWN BY NUMBERS BETWEEN STATION IDENTIFICATION AND WIRE COLOR CODE.
- STATION NUMBER      DESTINATION WITHIN STATION  
 1-3                      923  
                                  WIRE COLOR CODE

TM 856-91

Figure 104. Radio Receiver R-390/URR, calibration oscillator subchassis, wiring diagram.



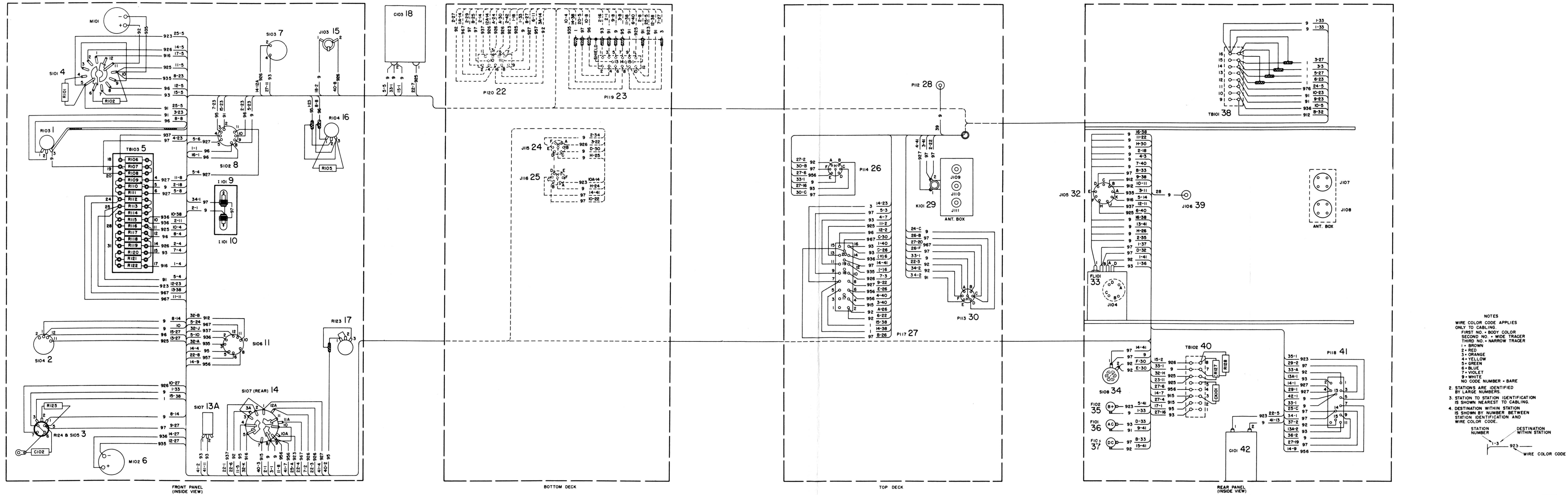

- NOTES
- WIRE COLOR CODE APPLIES ONLY TO CABLING.
- FIRST NO. = BODY COLOR  
 SECOND NO. = WIDE TRACER  
 THIRD NO. = NARROW TRACER
- 1 = BROWN
  - 2 = RED
  - 3 = ORANGE
  - 4 = YELLOW
  - 5 = GREEN
  - 6 = BLUE
  - 7 = VIOLET
  - 9 = WHITE
  - NO CODE NUMBER = BARE
2. STATIONS ARE IDENTIFIED BY LARGE NUMBERS.
3. STATION TO STATION IDENTIFICATION IS SHOWN NEAREST TO CABLING.
4. DESTINATION WITHIN STATION IS SHOWN BY NUMBER BETWEEN STATION IDENTIFICATION AND WIRE COLOR CODE.
- STATION NUMBER      DESTINATION WITHIN STATION
- 1-3      923
- WIRE COLOR CODE

Figure 106. Radio Receiver R-390/URR, main frame, wiring diagram.

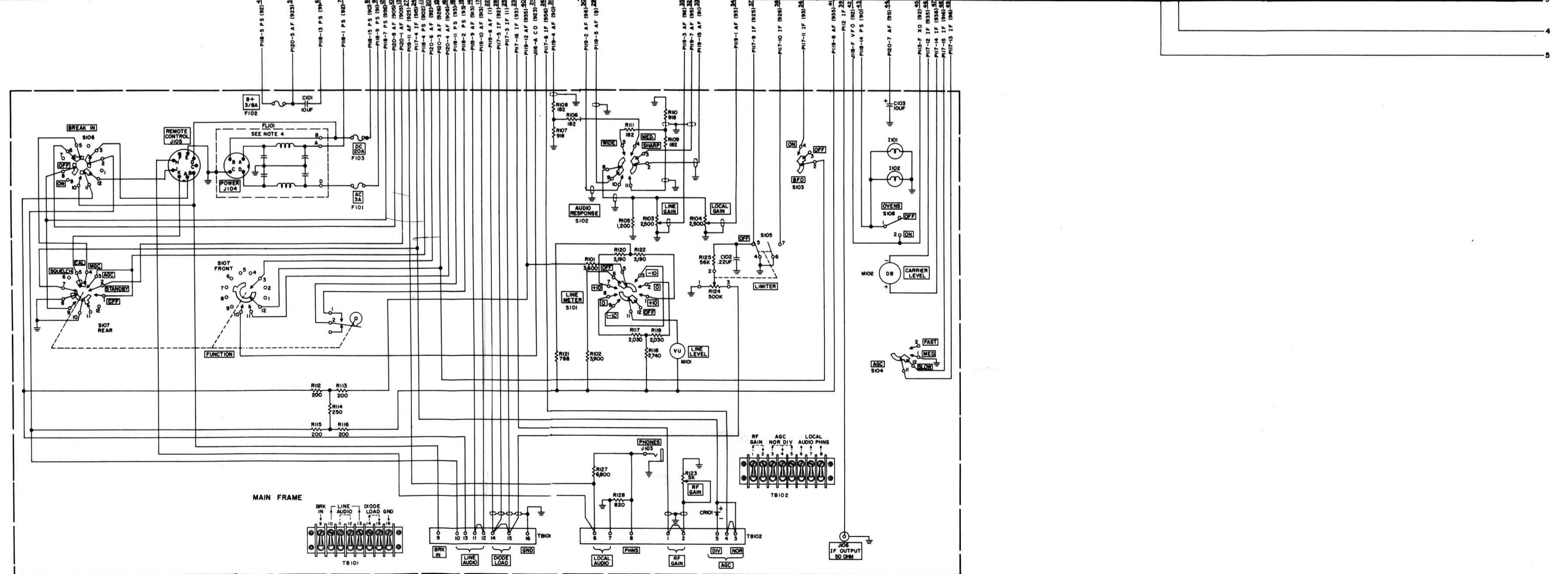
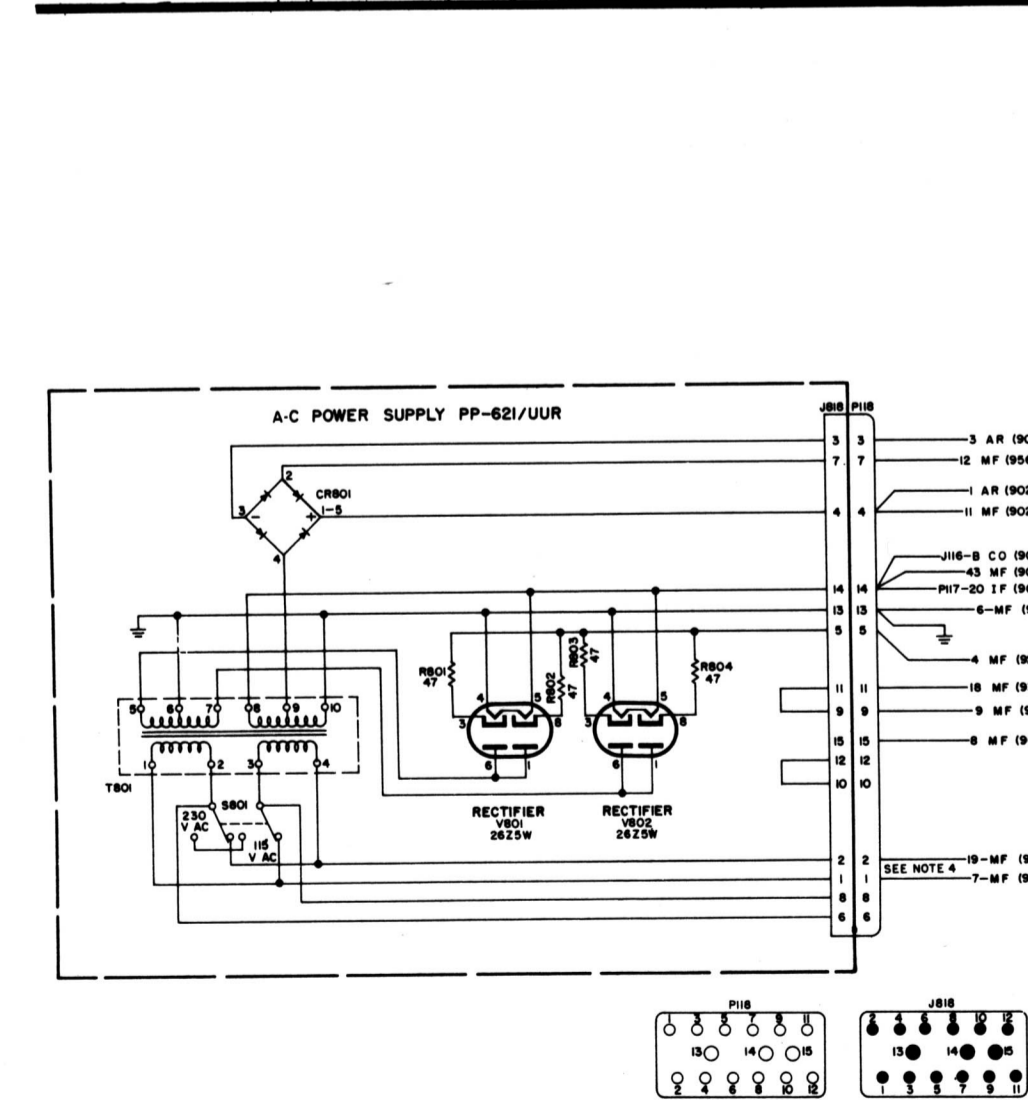
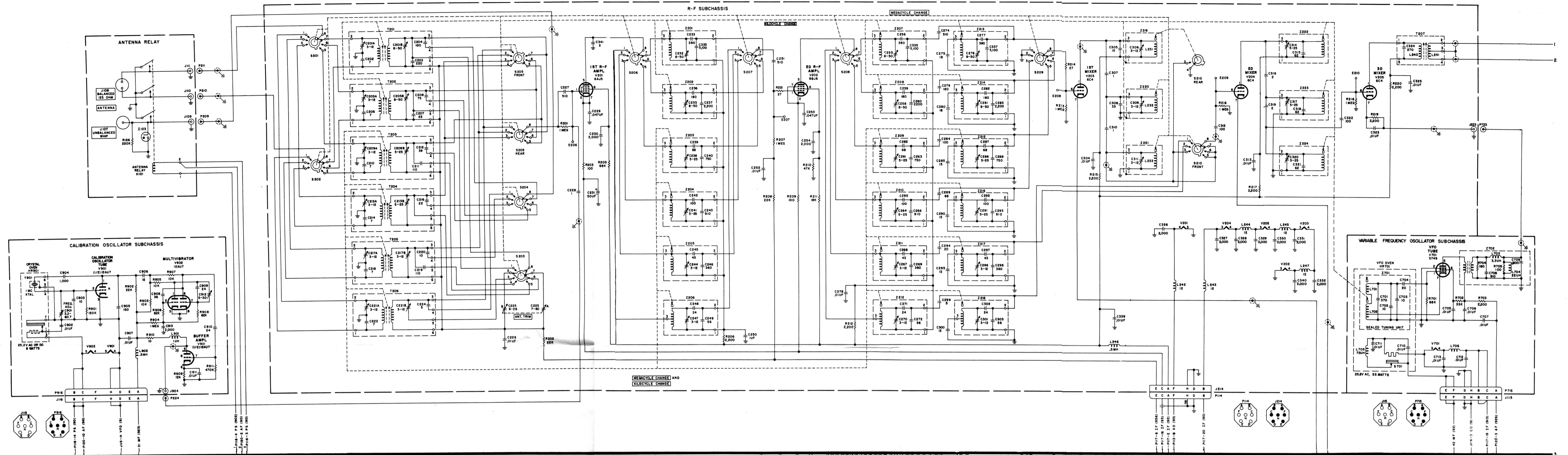

Figure 107 (Part 1). Radio Receiver R-390/URR, subchassis and interconnection diagram.



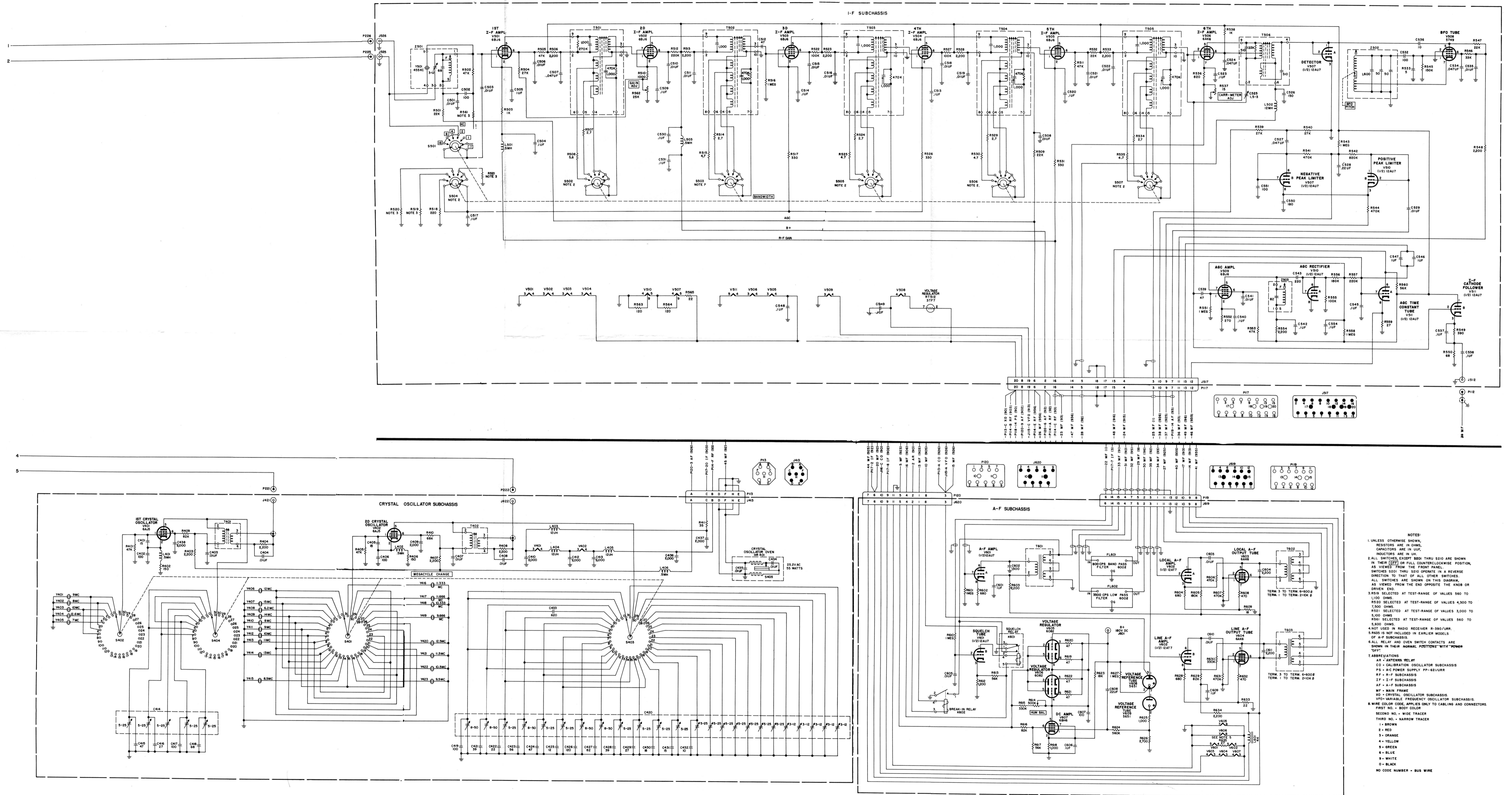
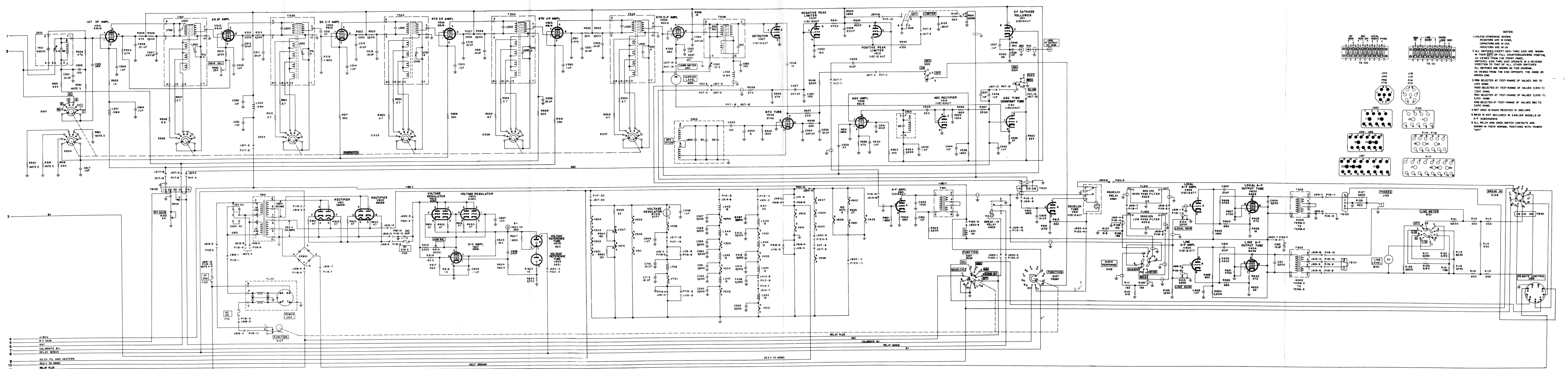

Figure 107 (Part 2). Radio Receiver R-390/URR, subchassis and interconnection diagram.





- NOTES:
- UNLESS OTHERWISE SHOWN, RESISTORS ARE IN OHMS, CAPACITORS ARE IN UUF, INDUCTORS ARE IN UH.
  - ALL SWITCHES, EXCEPT S201 THRU S210 ARE SHOWN IN THEIR OR FULL COUNTERCLOCKWISE POSITION, AS VIEWED FROM THE FRONT PANEL. SWITCHES S201 THRU S210 OPERATE IN A REVERSE DIRECTION TO THAT OF ALL OTHER SWITCHES. ALL SWITCHES ARE SHOWN ON THIS DIAGRAM, AS VIEWED FROM THE END OPPOSITE THE KNOB OR DRIVEN END.
  - R508 SELECTED AT TEST-RANGE OF VALUES 560 TO 100 OHMS.
  - R500 SELECTED AT TEST-RANGE OF VALUES 4,300 TO 7,200 OHMS.
  - R521 SELECTED AT TEST-RANGE OF VALUES 3,000 TO 5,100 OHMS.
  - R506 SELECTED AT TEST-RANGE OF VALUES 560 TO 5,600 OHMS.
  - NOT USED IN RADIO RECEIVER R-390/U/R.
  - R536 IS NOT INCLUDED IN EARLIER MODELS OF A-F SUBCIRCUIS.
  - ALL RELAY AND OPEN SWITCH CONTACTS ARE SHOWN IN THEIR NORMAL POSITIONS WITH POWER "OFF".

- +180V
- R-F GAIN
- ACC
- CALIBRATE B+
- RELAY MINUS
- RELAY PLUS
- 25.2V FIL AND HEATERS
- 25.2V TO MR90
- RELAY PLUS

Figure 108 (Part 2). Radio Receiver R-390/U/R, schematic diagram.

